

Signal converter IO223 and IO223/CO SSI → IO – Link (V1.1)

Product features:

- 1x SSI input
- Master or Slave operation with clock frequencies up to 2 MHz
- For single turn and multi turn encoders with SSI formats from 10 ... 32 Bit
- Useful functions such as bit suppression, round-loop function, scaling, ...
- Simple device parameterization possible via IO - Link using various engineering tools
- Adjustable limit value monitoring possible
- Numerous connection options via extension option (IO223/CO)
(three additional control inputs and two additional control outputs)
- Generation of pending events (e.g. upper limit value exceeded, SSI error bit active, ...) possible
- Auxiliary voltage output 5 and 24VDC for encoder supply
- Compact rail housing to EN60715

Available options:

IO223:	Basic device with SSI input and auxiliary voltage output
IO223/CO:	Basic device with SSI input, auxiliary voltage output and 3x HTL PNP control inputs and 2x PNP control outputs

Die deutsche Beschreibung ist verfügbar unter:

https://www.motrona.com/fileadmin/files/bedienungsanleitungen/lo223_d.pdf



The English description is available at:

https://www.motrona.com/fileadmin/files/bedienungsanleitungen/lo223_e.pdf



La description en français est disponible sur:

https://www.motrona.com/fileadmin/files/bedienungsanleitungen/lo223_f.pdf



The operator software OS (freeware) is available at:

<https://www.motrona.com/en/support/software.html>



Version:	Description:
lo223_01a_oi/tgo/mbo/Feb.-24	First Version

Legal notices:

All contents included in this manual are protected by the terms of use and copyrights of motrona GmbH. Any reproduction, modification, usage or publication in other electronic and printed media as well as in the internet requires prior written authorization by motrona GmbH.

Table of Contents

1. Safety Instructions and Responsibility	4
1.1. General Safety Instructions	4
1.2. Use according to the intended purpose	4
1.3. Installation	5
1.4. EMC Guidelines	6
1.5. Cleaning, Maintenance and Service Notes.....	6
2. Introduction	7
2.1. Function diagram	8
3. Electrical Connections	9
3.1. DC Power Supply	9
3.2. Auxiliary voltage output.....	9
3.3. SSI Inputs	10
3.4. Control Inputs (only with option "CO").....	11
3.5. Control Outputs (only with option "CO").....	12
3.6. IO-Link Interface.....	13
3.6.1. Useable IO Link masters	13
3.6.2. Communications data	13
3.6.3. Features	13
3.6.4. Front LED	13
3.6.5. Connection of the IO Link interface.....	14
3.6.6. Parameter data	14
3.6.7. System Commands	16
3.6.8. IO-Link Process data	17
3.6.9. Error types	18
3.6.10. Events.....	19
4. Parameter / Overview – Menu Structure	20
4.1. General Menu	21
4.2. SSI Properties	22
5. Attachment	25
5.1. Parameter / serial codes.....	25
5.2. Reading SSI-Value	26
5.3. Internal processing and calculation of SSI value.....	27
5.4. Dimensions	29
5.5. Technical Specifications.....	30

1. Safety Instructions and Responsibility

1.1. General Safety Instructions

This operation manual is a significant component of the unit and includes important rules and hints about the installation, function and usage. Non-observance can result in damage and/or impairment of the functions to the unit or the machine or even in injury to persons using the equipment!

Please read the following instructions carefully before operating the device and observe all safety and warning instructions! Keep the manual for later use.

A pertinent qualification of the respective staff is a fundamental requirement in order to use these manual. The unit must be installed, connected and put into operation by a qualified electrician.

Liability exclusion: The manufacturer is not liable for personal injury and/or damage to property and for consequential damage, due to incorrect handling, installation and operation. Further claims, due to errors in the operation manual as well as misinterpretations are excluded from liability.

In addition the manufacturer reserves the right to modify the hardware, software or operation manual at any time and without prior notice. Therefore, there might be minor differences between the unit and the descriptions in operation manual.

The raiser respectively positioner is exclusively responsible for the safety of the system and equipment where the unit will be integrated.

During installation or maintenance all general and also all country- and application-specific safety rules and standards must be observed.

If the device is used in processes, where a failure or faulty operation could damage the system or injure persons, appropriate precautions to avoid such consequences must be taken.

1.2. Use according to the intended purpose

The unit is intended exclusively for use in industrial machines, constructions and systems. Non-conforming usage does not correspond to the provisions and lies within the sole responsibility of the user. The manufacturer is not liable for damages which have arisen through unsuitable and improper use.

Please note that device may only be installed in proper form and used in a technically perfect condition (in accordance to the Technical Specifications). The device is not suitable for operation in explosion-proof areas or areas which are excluded by the EN 61010-1 standard.

1.3. Installation

The device is only allowed to be installed and operated within the permissible temperature range. Please ensure an adequate ventilation and avoid all direct contact between the device and hot or aggressive gases and liquids.

Before installation or maintenance, the unit must be disconnected from all voltage-sources. Further it must be ensured that no danger can arise by touching the disconnected voltage-sources.

Devices which are supplied by AC-voltages must be connected exclusively by switches, respectively circuit-breakers with the low voltage network. The switch or circuit-breaker must be placed as near as possible to the device and further indicated as separator.

Incoming as well as outgoing wires and wires for extra low voltages (ELV) must be separated from dangerous electrical cables (SELV circuits) by using a double resp. increased isolation.

All selected wires and isolations must conform to the provided voltage- and temperature-ranges. Further all country- and application-specific standards, which are relevant for structure, form and quality of the wires, must be ensured. Indications about the permissible wire cross-sections for wiring are described in the Technical Specifications.

Before first start-up it must be ensured that all connections and wires are firmly seated and secured in the screw terminals. All (inclusively unused) terminals must be fastened by turning the relevant screws clockwise up to the stop.

Overvoltages at the connections must be limited to values in accordance to the overvoltage category II.

1.4. EMC Guidelines

All motrona devices are designed to provide high protection against electromagnetic interference. Nevertheless you must minimize the influence of electromagnetic noise to the device and all connected cables.

Therefore the following measures are mandatory for a successful installation and operation:

- **Use shielded cables for all signal and control input and output lines.**
- **Cables for digital controls (digital I/O, relay outputs) must not exceed a length of 30 m and are allowed for in building operation only**
- Use shield connection clamps to connect the cable shields properly to earth
- The wiring of the common ground lines must be star-shaped and common ground must be connected to earth at only one single point
- The device should be mounted in a metal enclosure with sufficient distance to sources of electromagnetic noise.
- Run signal and control cables apart from power lines and other cables emitting electromagnetic noise.

Please also refer to motrona manual "General Rules for Cabling, Grounding, Cabinet Assembly". You can download that manual by the link

<https://www.motrona.com/en/support/general-certificates.html>

1.5. Cleaning, Maintenance and Service Notes

To clean the front of the unit please use only a slightly damp (not wet!), soft cloth. For the rear no cleaning is necessary. For an unscheduled, individual cleaning of the rear the maintenance staff or assembler is self-responsible.

During normal operation no maintenance is necessary. In case of unexpected problems, failures or malfunctions the device must be shipped for back to the manufacturer for checking, adjustment and reparation (if necessary). Unauthorized opening and repairing can have negative effects or failures to the protection-measures of the unit.

2. Introduction

The device can be used as a SSI absolute encoder. The SSI value read in is transmitted cyclically as a process value via the IO link after any Gray to binary conversion that may have been carried out. Helpful functions such as bit blanking, concentricity function or zero offset can also be activated beforehand.

The "CO" extension option also has three HTL PNP control inputs and two PNP switching outputs. These can be used to indicate that limit values set by the user have been exceeded or not reached. The current status of the digital inputs and outputs is also transmitted cyclically with the process input data, so that a wide range of requirements can be covered here.

In addition, any pending events (e.g. lower limit value exceeded,...) can be generated if desired by the user. The individual device parameters can be set and saved using various engineering tools or during operation via IO-Link. The supported "data storage" mechanism makes device replacement easy and hassle-free.

2.1. Function diagram

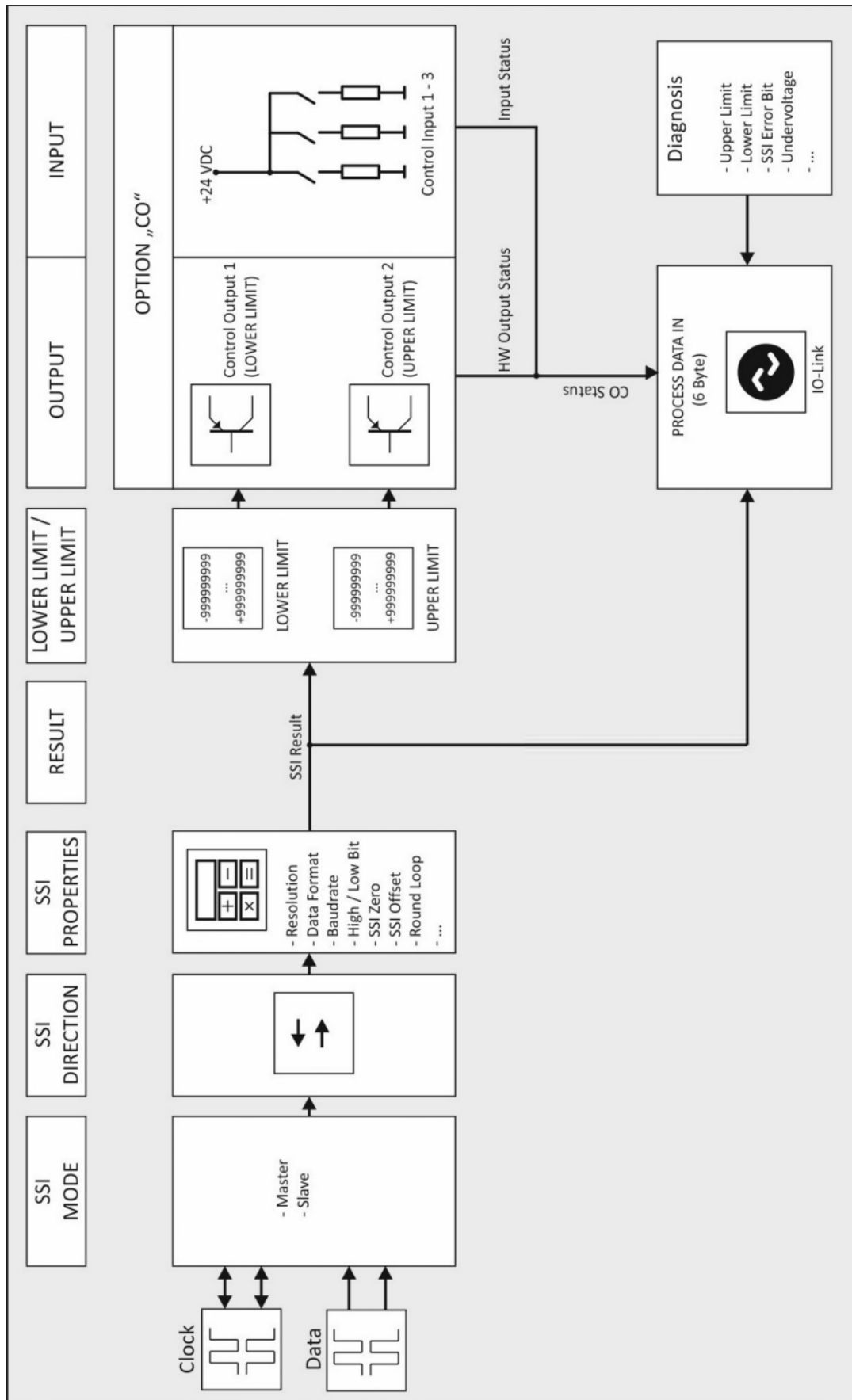

3. Electrical Connections

The terminal screws should be tightened with a slotted screwdriver (blade width 2mm).

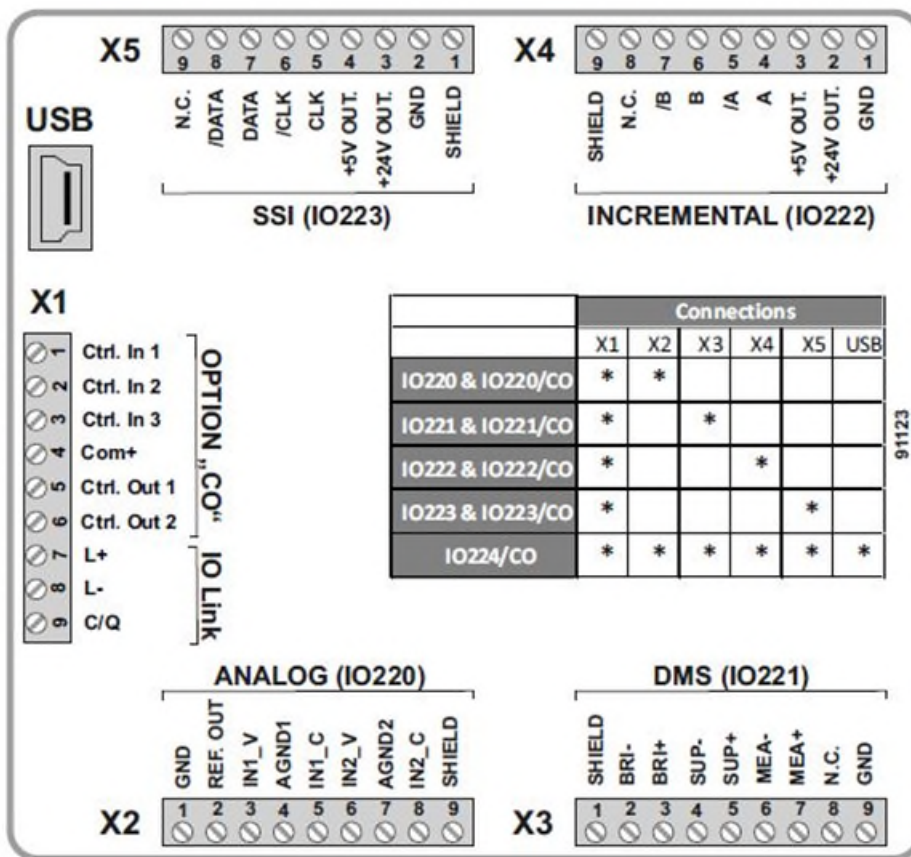

3.1. DC Power Supply

The unit accepts DC supply from 18 to 30 V at the terminals X1 pins 7 (+) and 8 (-). The power consumption depends on the level of the supply voltage with approx. 75 mA (at 24V).

All GND terminals are internally interconnected.

3.2. Auxiliary voltage output

A short-circuit-proof 24 VDC resp. 5VDC auxiliary voltage is available at terminal X5 pins 2,3 and 4, which can be used as an encoder supply, for example. The 24 VDC output voltage depends on the device supply. The maximum current load capacity of the auxiliary voltage output can be found in the technical data in the appendix.

3.3. SSI Inputs

At terminal X5 pins 5, 6, 7 and 8 the connection for CLK , /CLK, DATA and /DATA is available. The basic settings must be set in the parameters in the SSI PROPERTIES menu.

Connection for **MODE Master:**

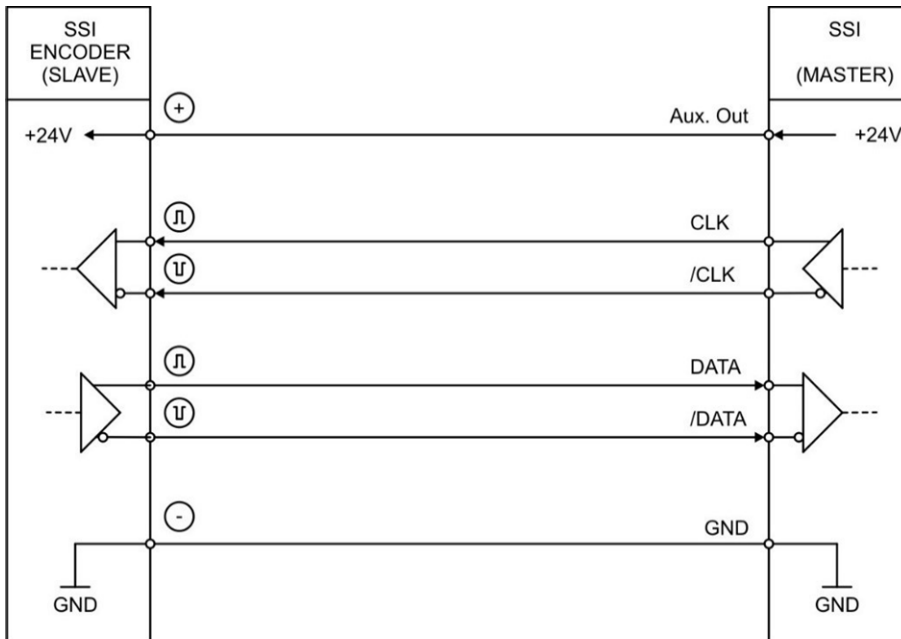

Connection for **MODE Slave:**

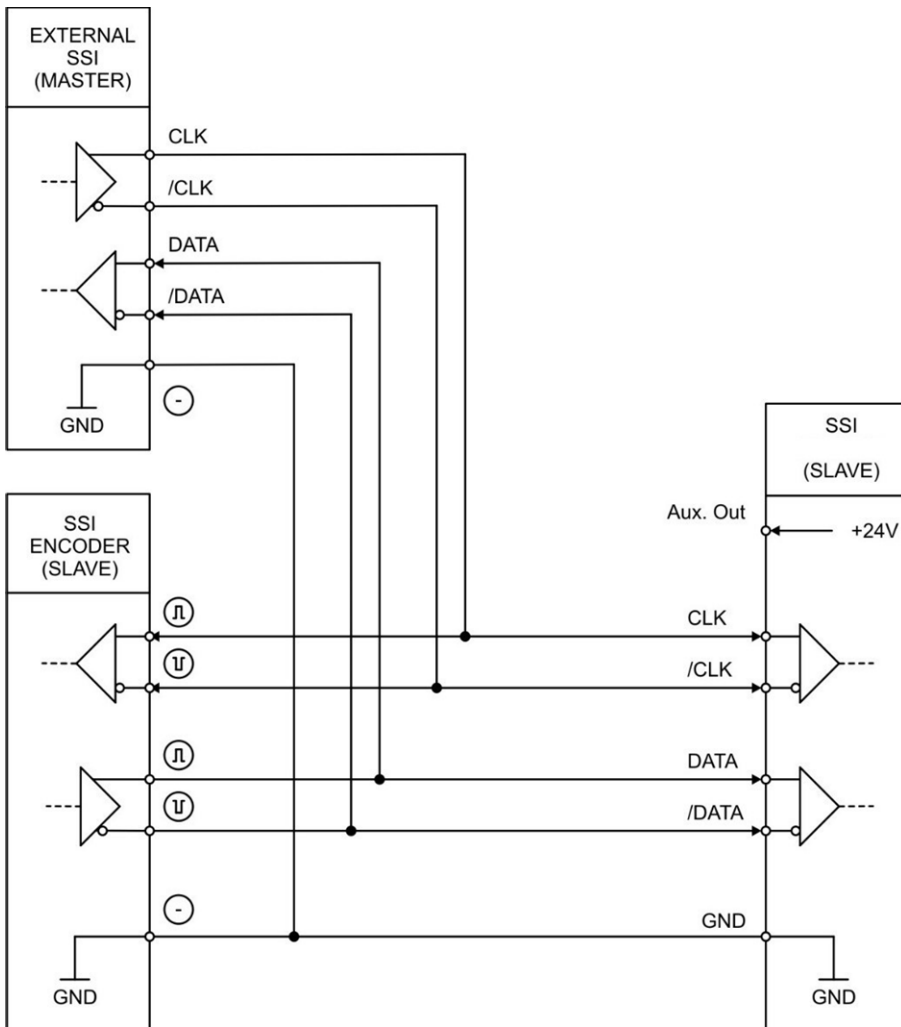

ATTENTION:



The Master mode is preset as the "Default" setting. This means that the clock signal is generated by the signal converter!

If another device is used as the SSI master, the SSI MODE parameter must be switched to "Slave" mode before the electrical wiring of the SSI interface!

3.4. Control Inputs (only with option "CO")

Three control inputs with HTL PNP characteristics are available on terminal X1, pins 1, 2 and 3. The current state of the control inputs is cyclically exchanged with the process data and can therefore be used for a wide variety of functions. (e.g. as a trigger signal for triggering a "system command" or for reading out actual values)

Connection of the control inputs:

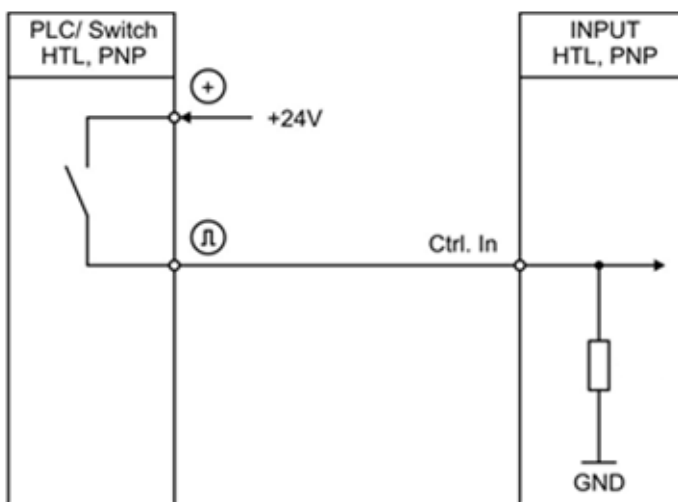

Unconnected control inputs are always "LOW".

All inputs are designed to receive impulses from an electronic impulse source.



Notice for mechanical switching contacts:

When exceptionally mechanical contacts are used, please connect an external capacitor between GND (-) and the corresponding input (+). A capacity of 10 μF will reduce the input frequency to 20 Hz and miscounting due to contact bouncing will be eliminated.

3.5. Control Outputs (only with option "CO")

Two control outputs are available on terminal X1, pins 5 and 6. These signal, when limit values defined by the user have been undercut or exceeded. Control output 1 always reacts as soon as the lower limit value is undercut. Control output 2 always reacts as soon as the upper limit value has been exceeded.

These outputs Ctrl. Out 1 and 2 are designed as high side drivers. The status of the outputs is also transmitted cyclically with the IO-Link process data.

The switching voltage is determined by the external voltage supplied to terminal X1 pin 4 (COM+) External damping measures are recommended for switching inductive loads.

Connection of the control outputs:

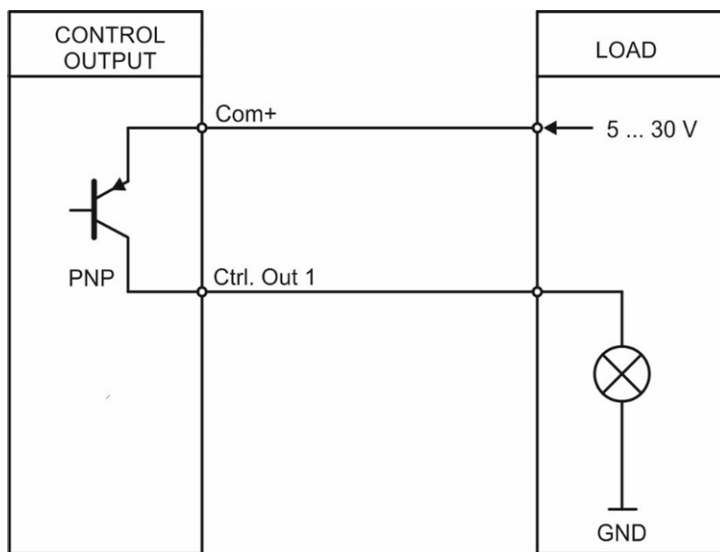

3.6. IO-Link Interface

This chapter contains important notes and information regarding IO-Link communication data. In addition to general information on the IO-Link connection, the parameter data of the device, the exchanged process data and the implemented system commands, error codes and events are discussed.

3.6.1. Useable IO Link masters

All IO-Link masters that support IO-Link Standard V1.1

3.6.2. Communications data

Parameters	Values
Communication speed	COM 3
Transmission rate	230,4 kbit/s
IO-Link Revision	V1.1
Cycle time	min. 1 ms
Port class	Class A

3.6.3. Features

Feature	Supports
Block parametrization	Yes
Data Storage	Yes
Events	Yes
SIO Mode	No

3.6.4. Front LED

In the case of devices without the "CO" option, the green LED on the front is used exclusively as a ready-to-operate display. As soon as a supply voltage has been applied to the device, it lights up continuously.

For devices with the extended "CO" option, the green LED on the front serves as a ready-to-operate display. It also signals the current IO-Link system status.

LED lights up continuously:

The device is connected to the supply voltage and there is no IO-Link communication. The device is in "START UP MODE".

LED flashes at 0.5 Hz:

Device is connected to the supply voltage and IO-Link communication is currently in "PREOPERATE MODE" (no cyclic data exchange takes place).

LED flashes at 1 Hz cycle:

The device is connected to the supply voltage and IO-Link communication is currently in "OPERATE MODE" (cyclic data exchange is taking place).

3.6.5. Connection of the IO Link interface

An interface for connecting to an IO-Link master port is available on terminal X1 pin 7 (L-), 8 (L+) and 9 (C/Q). Figure 1 shows the pin assignment of a standard M12 connector plug.

Assignment		
	Pin 1	Clamp L+
	Pin 2	Not connected
	Pin 3	Clamp L-
	Pin 4	IO-Link data line, C/Q

Fig. 1: Pin assignment M12 connection plug

Pin	Wire color
1 (L+)	brown
2 (n.c.)	white
3 (L-)	blue
4 (C/Q)	black

3.6.6. Parameter data

ISDU Index	DPP1 Index	Name of the Parameter	Access	Length in bytes	Default Value	Range
Identification Menu						
	7	VendorID	R	2	980 / 0x 03D4	-
	8					
	9	Device ID	R	3	2359553 / 0x240101	-
	10					
	11					
16		Vendor Name	R	12	motrona GmbH	-
17		Vendor Text	R	21	http://www.motrona.com	-
18		Product Name	R	15	signalconverter	-
19		Product ID	R	8	IO223 or IO223/CO	-
20		Product Text	R	36	SSI converter with IO-Link interface	-
21		Serial Number	R	9	-	-
22		Hardware Revision	R	7	e.g.: 224IO10	-
23		Firmware Revision	R	8	e.g.: IO22301A	-
24		Application Specific Tag	R/W	Max. 32	***	-
36		Device Status	R	1	0x00	0: Device is working properly 1: Maintenance required 2: Out of specification 3: functional test 4: Error 5-255: Reserved
40		Prozess Data Input	R	6	-	-

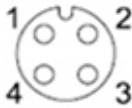
ISDU Index	DPP1 Index	Name of the Parameter	Access	Length in bytes	Default Value	Range
GENERAL MENU						
272		LOWER LIMIT	R/W	4	0	-999999999 .. +999999999
273		UPPER LIMIT	R/W	4	+999999999	-999999999 .. +999999999
274		DIAGNOSIS SETUP	R/W	4	0 (0x00)	0..31
SSI PROPERTIES						
258		SSI MODE	R/W	4	0	0..1
259		ENCODER RESOLUTION	R/W	4	25	10..32
260		DATA FORMAT	R/W	4	0	0..1
261		BAUD RATE	R/W	4	3	0..5
262		HIGH BIT	R/W	4	25	1..32
263		LOW BIT	R/W	4	1	1..32
264		SSI ZERO	R/W	4	0	0..+999999999
265		SSI OFFSET	R/W	4	0	0..+999999999
266		ROUND LOOP VALUE	R/W	4	0	0..+999999999
267		SAMPLING TIME (s)	R/W	4	10	1..9999
268		ERROR BIT	R/W	4	0	0..32
269		ERROR POLARITY	R/W	4	0	0..1
270		SSI DIRECTION	R/W	4	0	0..1
Observation Menu						
657		Maximum Value	R	4	-	-
658		Minimum Value	R	4	-	-
659		SSI Read Value	R	4	-	-
660		SSI Data Value	R	4	-	-

3.6.7. System Commands



A system command is a write-only parameter that causes an action in the device. To invoke the desired action, the corresponding value must be written to **index 2, subindex 0**. If the desired command is a static command (s), this command remains active until the corresponding value is written again to index 2, subindex 0. By resending the command, the action is terminated.

Predefined commands

Name	Index	Subindex	Value	Description of the action	dynamic (d) / static (s)
RESTORE FACTORY SETTINGS	2	0	130	Resets all parameters to factory settings.	(d)
APPLICATION RESET	2	0	129	Resets all device parameters to "default values".	(d)

Application specific commands

Name	Index	Subindex	Value	Description of the action	dynamic (d) / static (s)
CLEAR MIN/MAX VALUES	2	0	160	Reset of the Min. / Max. values.	(d)
ZERO POSITION	2	0	162	Transfer of the current SSI position to the "SSI ZERO" parameter (encoder zero offset).	(d)
RESET TO ZERO	2	0	163	Transfer of the currently recorded position value (after bit blanking and any encoder zero offset) to the "SSI OFFSET" parameter (display zero offset).	(d)
STORE EEPROM	2	0	168	Current parameter set is stored non-volatile in the EEPROM.	(d)

3.6.8. IO-Link Process data

Process input data (Total: 6 Byte):

Bit	Byte	Subindex	Description
Bit 0	Byte 5	1	Diagnosis: Upper set threshold (Upper Limit) exceeded
Bit 1		2	Diagnosis: Below the lower set threshold value (Lower Limit)
Bit 2		3	Diagnosis: Device supply undervoltage (< 17 V)
Bit 3		4	Diagnosis: SSI value outside the measuring range (> 999999999 resp. < --999999999)
Bit 4		5	Diagnosis: SSI Error Bit is active
Bit 5		6	Diagnosis: Device test – Error (For test purposes only!)
Bit 6		7	Diagnosis: Device test – Warning (For test purposes only!)
Bit 7		8	Diagnosis: Reserve
Bit 0	Byte 4	9	Input State: Control Input 1 (0: OFF / 1: ON)
Bit 1		10	Input State: Control Input 2 (0: OFF / 1: ON)
Bit 2		11	Input State: Control Input 3 (0: OFF / 1: ON)
Bit 3		12	HW Output State: Control Output 1 (0: OFF / 1: ON)
Bit 4		13	HW Output State: Control Output 2 (0: OFF / 1: ON)
Bit 5		14	Reserved
Bit 6		15	Reserved
Bit 7		16	Reserved
-	Byte 0...3	17	Process value 1: SSI Wert - (Data type: Int32)



The acyclic request address of the process input data is **index 40**. The corresponding **subindex** and the corresponding data type of the desired value that is to be read can be found in the table above.

3.6.9. Error types

Error code	Name	Description
32768 / 0x 8000	Application errors in the device-no details	Access was denied by the device. No detailed information is available.
32785 / 0x 8011	Index does not exist	Access to a non-existent index.
32786 / 0x 8012	Subindex does not exist	Access to a non-existent subindex..
32800 / 0x 8020	Service not available at this time	The parameter cannot be accessed at this moment. The device does not allow this in the current state.
32803 / 0x 8023	Access denied	Write access to a read-only parameter.
32816 / 0x 8030	Parameter value out of range	Parameter value is outside the allowed range of values.
32817 / 0x 8031	Parameter value greater than specified range	The written parameter value is greater than the specified value range.
32818 / 0x 8032	Parameter value less than specified range	The written parameter value is smaller than the specified value range.
32819 / 0x 8033	Parameter length too large	Parameter length is greater than allowed.
32820 / 0x 8034	Parameter length too small	Parameter length is less than allowed.
32821 / 0x 8035	Function not available	The device does not support the command.
32822 / 0x 8036	Function not available at this time	The command is not supported by the device in its current state.
32832 / 0x 8040	Invalid parameter set	Written single parameter value collides with the other parameter settings.
32833 / 0x 8041	Inconsistent parameter set	Inconsistencies were detected at the end of the block parameter transfer. The device plausibility check failed.
32898 / 0x 8082	Application not ready	Access was denied because the device is not ready.

3.6.10. Events

Code	Type	Device State	Condition
0x180E	Warning	0x00	Diagnosis: Upper set threshold (Upper Limit) exceeded
0x180F	Warning	0x00	Diagnosis: Below the lower set threshold value (Lower Limit)
0x180C	Warning	0x02	Diagnosis: Device supply undervoltage (< 17 V)
0x180D	Warning	0x02	Diagnosis: SSI value outside the measuring range (> +999999999 resp. < -999999999)
0x1852	Error	0x04	Diagnosis: SSI Error Bit is active
0x8D68	Error	0x00	Device test – Error (For test purposes only!)
0x8D04	Warning	0x00	Device test – Warning (For test purposes only!)

4. Parameter / Overview – Menu Structure

The device is parameterized via the IO-Link interface using a suitable engineering tool, which is usually provided by the IO-Link master manufacturers.

This section shows the overview of the individual menus and their parameters. The menu name is written in bold, the associated parameters are arranged directly under the menu name

Menu / Parameter
GENERAL MENU
LOWER LIMIT
UPPER LIMIT
DIAGNOSIS SETUP
SSI PROPERTIES
SSI MODE
ENCODER RESOLUTION
DATA FORMAT
BAUD RATE
HIGH BIT
LOW BIT
SSI ZERO
SSI OFFSET
ROUND LOOP VALUE
SAMPLING TIME (S)
ERROR BIT
ERROR POLARITY
SSI DIRECTION

4.1. General Menu

The general parameters for this signal converter are described in this menu.

LOWER LIMIT		
This parameter defines the <u>lower</u> limit.		
	-999999999	Smallest value
	0	Default value
	+999999999	Highest value



If the value set here is underrun, control output 1 is set, the corresponding bit is set in the "Diagnosis Byte" of the cyclic process data and, if necessary, an "Event Appears" is generated (provided that the generation of this event was previously activated accordingly in "DIAGNOSIS SETUP").

UPPER LIMIT		
This parameter defines the <u>upper</u> limit.		
	-999999999	Smallest value
	+999999999	Default value
	+999999999	Highest value



If the value set here is exceeded, control output 2 is set, the corresponding bit is set in the "Diagnosis Byte" of the cyclic process data and, if necessary, an "Event Appears" is generated (provided that the generation of this event was previously activated accordingly in "DIAGNOSIS SETUP").

DIAGNOSIS SETUP		
This parameter can be used to specify which " <u>events</u> " are to be generated by the device.		
Corresponding bit = 1 → associated event is generated as soon as the event is pending (appears) or no longer pending (disappears).		
Corresponding bit = 0 → associated event is <u>not</u> generated.		
Min:	0x00	
Default:	0x00	
Max:	0x1F	
Bit 0	0	Upper set threshold (Upper Limit) exceeded
Bit 1	0	Below the lower set threshold value (Lower Limit)
Bit 2	0	Device supply undervoltage (< 17 V)
Bit 3	0	Measured value outside the range (> 999999999 bzw. < -999999999)
Bit 4	0	SSI Error Bit active
Bit 5	0	Reserved
Bit 6	0	Reserved
Bit 7	0	Reserved



Notice:

The "Diagnosis Byte" in the cyclic process data (byte 5) always shows which events are currently pending. Only the associated events can be switched on or off with the appropriate setting of this parameter.

4.2. SSI Properties

The individual parameters for SSI operation are described in this menu.

SSI MODE		
SSI Setting of the desired operating mode (Master or Slave)		
0	MASTER	Master-Mode: Clock for SSI encoder comes from the device
1	SLAVE	Slave-Mode: Clock for SSI encoder comes from the external master.

ENCODER RESOLUTION		
Resolution of the SSI encoder (total number of bits including any existing error bit!)		
	10	Smallest value
	25	Default value
	32	Highest value

DATA FORMAT		
Setting the SSI code of the encoder used (binary or gray)		
0	GRAY CODE	SSI-Code Gray
1	BINARY CODE	SSI-Code Binary

BAUD RATE		
Clock frequency of SSI telegrams		
0	2 MHZ	N.A.
1	1.5 MHZ	N.A.
2	1 MHZ	Clock frequency 1 MHz
3	500 KHZ	Clock frequency 500 kHz
4	250 KHZ	Clock frequency 250 kHz
5	100 KHZ	Clock frequency 100 kHz

HIGHT BIT (for bit blanking)		
Defines the highest evaluated bit (MSB) for bit blanking		
	01	Smallest value
	25	Default value
	32	Highest value



If all bits are to be evaluated, **HIGHT BIT** must be set to the total number of data bits.

Continuation „SSI Properties“:

LOW BIT (for bit blanking) Defines the lowest evaluated bit (LSB) for bit blanking		
	01	Smallest value
	...	
	32	Highest value



If all bits are to be evaluated, **LOW BIT** must be set to "01".

SSI ZERO In the case of a "ZERO POSITION" command (via System Command), the current SSI position of the encoder is transferred to the "SSI ZERO" parameter and the actual encoder zero point is shifted accordingly. (Encoder zero offset)		
	0	Smallest value
	...	
	+999999999	Highest value

SSI OFFSET In case of a "RESET TO ZERO" command (via System Command), the currently recorded position value (after bit blanking and any encoder zero offset) is transferred to the "SSI OFFSET" parameter and the measurement result is set to zero.		
	0	Smallest value
	...	
	+999999999	Highest value



From the new zero point, you can now move in positive and negative direction, depending on the direction of rotation (-xxx ... 0 ... +xxx)

ROUND LOOP VALUE Defines the number of encoder steps when a round-loop function is desired.		
	0	Round-loop function is turned off.
	...	
	+999999999	Number of steps for the round-loop function.

SAMPLING TIME (S) Determines the read cycle for the SSI telegram in the Master MODE. (Time interval between two clock cycles.)		
	0.001	Minimum measurement time in seconds
	0.010	Default value
	9.999	Maximum measurement time in seconds

Continuation „SSI Properties“:

ERROR BIT

Defines the position of any existing error bits that can be evaluated.

If the error bit is switched on, the corresponding bit is set in the "Diagnosis byte" of the cyclical process data as soon as the SSI error bit is detected. If the error bit is switched off, the bit in the "Diagnosis byte" always remains reset.

	0	No error bit available. Check for error bit is switched off.
	...	
	32	Position of the error bits to be evaluated. Check for error bit is switched off.



If the error bit is switched on, the corresponding bit is set in the "Diagnostics byte" of the cyclical process data as soon as the SSI error bit is active or reset as soon as the SSI error bit is no longer active.

If the error bit is switched off, the bit in the "Diagnosis byte" always remains reset.

ERROR POLARITY

Defined the polarity of the error bit in the case of an error

	ACTIVE LOW	Bit is low in the case of an error
	ACTIVE HIGH	Bit is high in the case of an error

SSI DIRECTION

This parameter reverses the traversing direction

0	FORWARD	Forward
1	REVERSE	Reverse

5. Attachment

5.1. Parameter / serial codes

#	Menu	Name	Ser.Code	Min	Max	Default
1	SSI PROPERTIES	SSI MODE	00	0	1	0
2	SSI PROPERTIES	ENCODER RESOLUTION	01	0	32	25
3	SSI PROPERTIES	DATA FORMAT	02	0	1	0
4	SSI PROPERTIES	BAUD RATE	03	0	5	3
5	SSI PROPERTIES	HIGH BIT	04	1	32	25
6	SSI PROPERTIES	LOW BIT	05	1	32	1
7	SSI PROPERTIES	SSI ZERO	06	0	999999999	0
8	SSI PROPERTIES	SSI OFFSET	07	0	999999999	0
9	SSI PROPERTIES	ROUND LOOP VALUE	08	0	999999999	0
10	SSI PROPERTIES	SAMPLING TIME (S)	09	1	10	9999
11	SSI PROPERTIES	ERROR BIT	10	0	32	0
12	SSI PROPERTIES	ERROR POLARITY	11	0	1	0
13	SSI PROPERTIES	SSI DIRECTION	12	0	1	0
14	GENERAL MENU	LOWER LIMIT	13	-999999999	999999999	0
15	GENERAL MENU	UPPER LIMIT	14	-999999999	999999999	999999999
16	GENERAL MENU	DIAGNOSIS SETUP	15	0	31	0
17	GENERAL MENU	FACTORY SETTINGS	16	0	1	0

5.2. Reading SSI-Value

The received data is always filled to 32 bit data length.

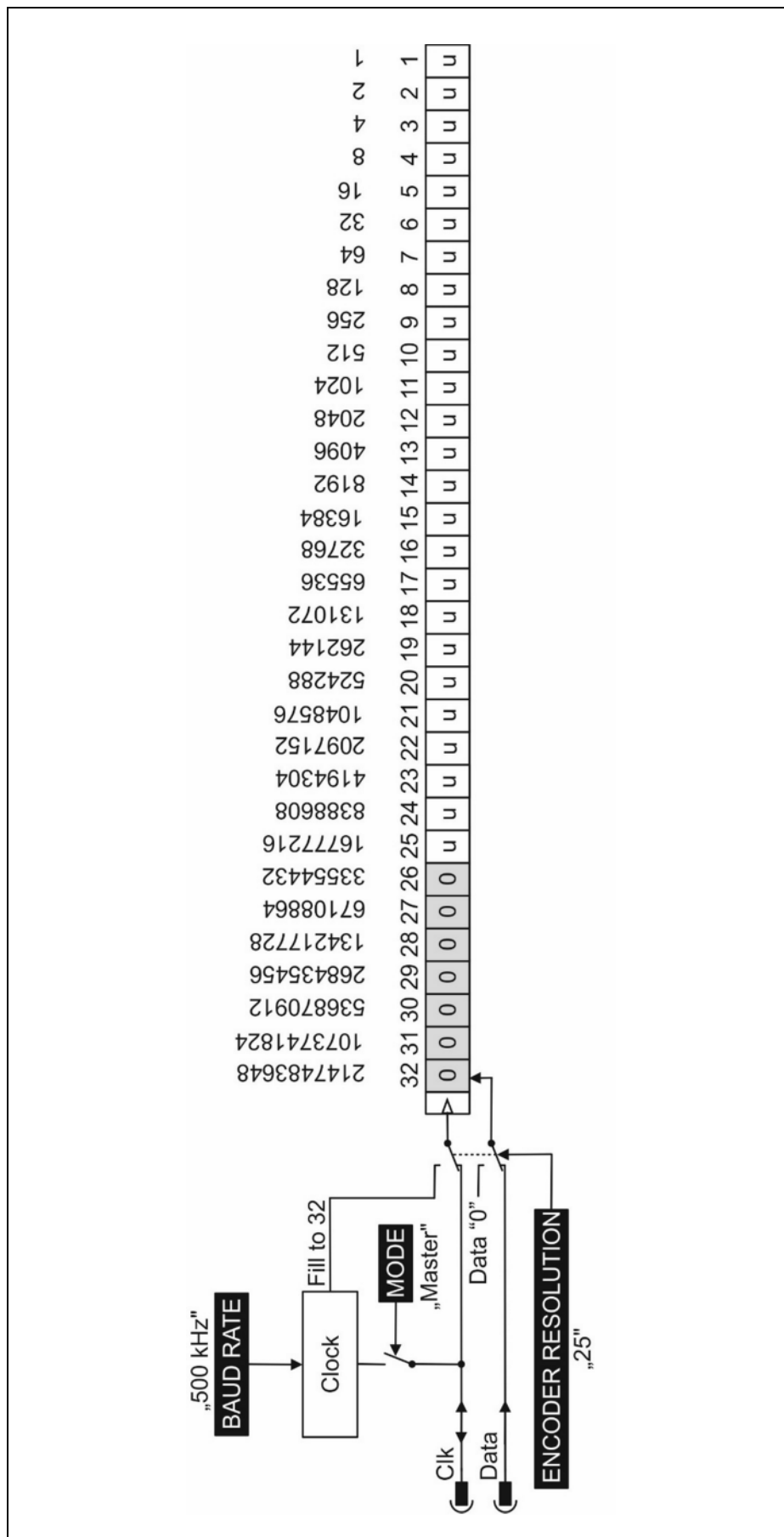

5.3. Internal processing and calculation of SSI value

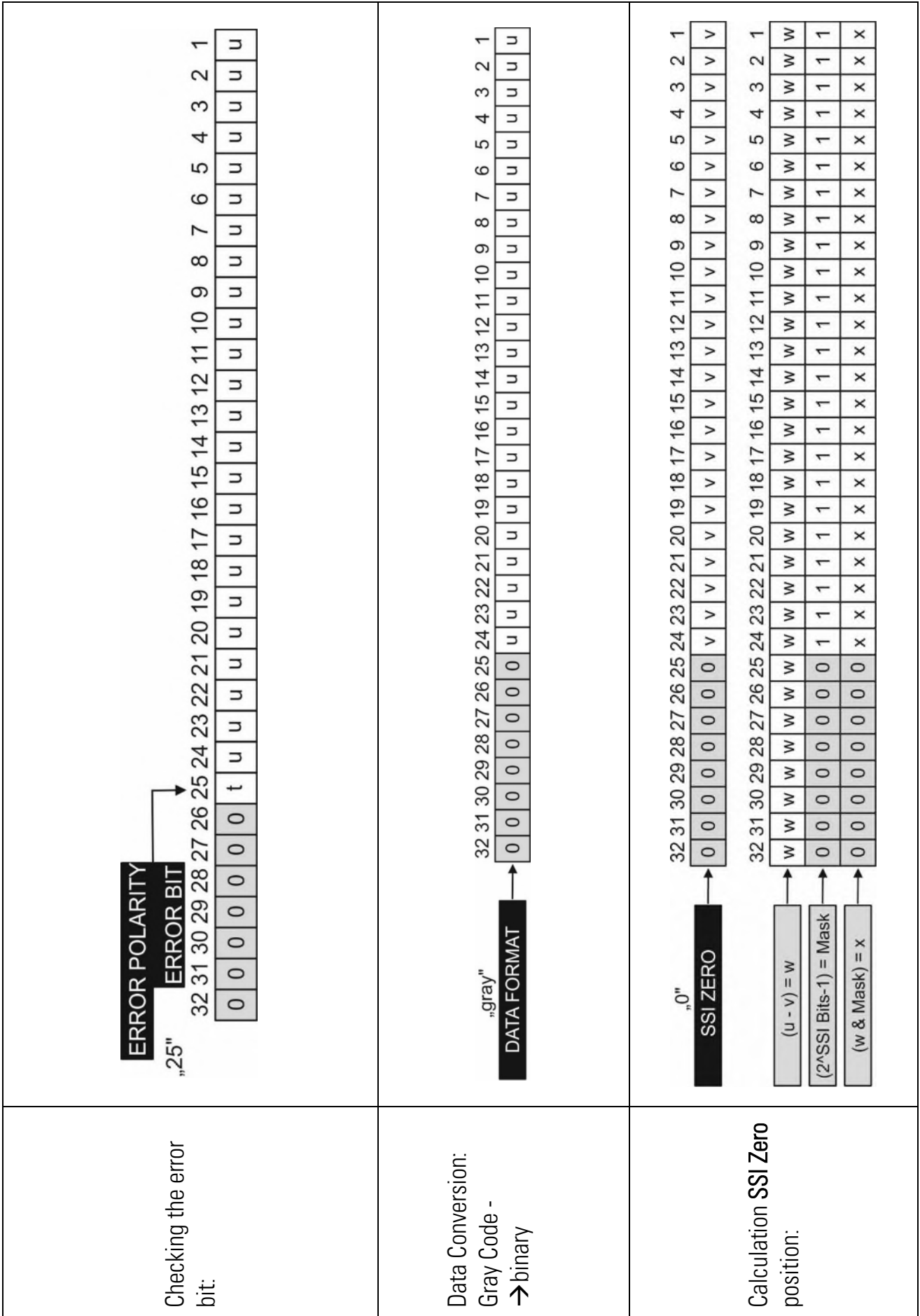

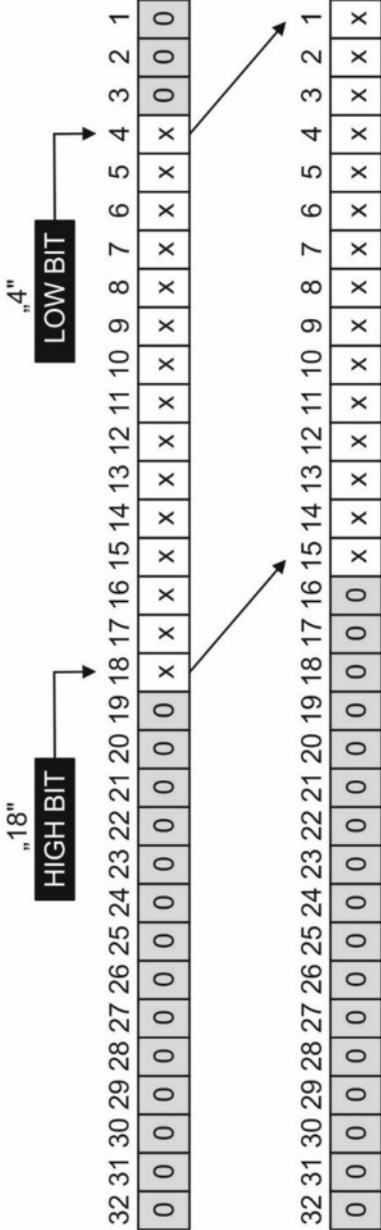
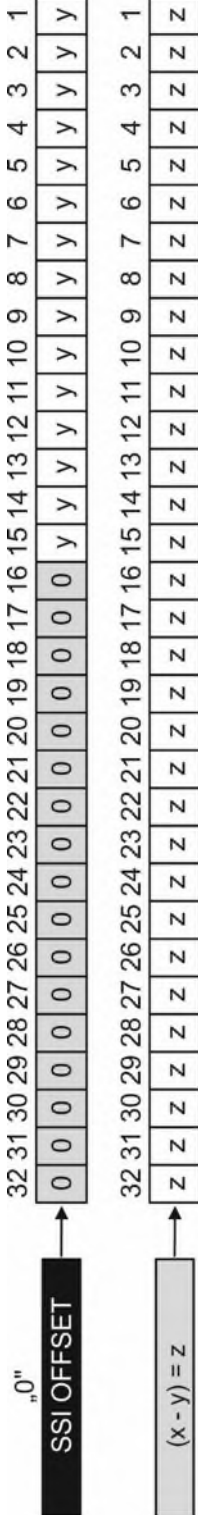
<p>Checking the direction of rotation:</p>	 <p>A horizontal sequence of bit positions from 32 down to 1. Bit 32 contains '0', while bits 31 through 1 contain 'x'. A black box labeled "DIRECTION" with a right-pointing arrow is positioned above bit 32.</p>
<p>Evaluation of the bit blanking:</p>	 <p>Two horizontal sequences of bit positions from 32 down to 1. In the top sequence, bits 20 through 4 are shaded gray. A black box labeled "HIGH BIT" with a right-pointing arrow points to bit 20. In the bottom sequence, bits 4 through 1 are shaded gray. A black box labeled "LOW BIT" with a right-pointing arrow points to bit 4. Arrows from the top sequence point to the corresponding shaded bits in the bottom sequence.</p>
<p>Calculation SSI Offset:</p>	 <p>Two horizontal sequences of bit positions from 32 down to 1. In the top sequence, bit 32 contains '0' and bits 31 through 1 contain 'y'. A black box labeled "SSI OFFSET" with a right-pointing arrow is positioned above bit 32. In the bottom sequence, bits 31 through 1 contain 'z'. A gray box labeled $(x - y) = z$ with a right-pointing arrow is positioned above bit 31.</p>

5.4. Dimensions

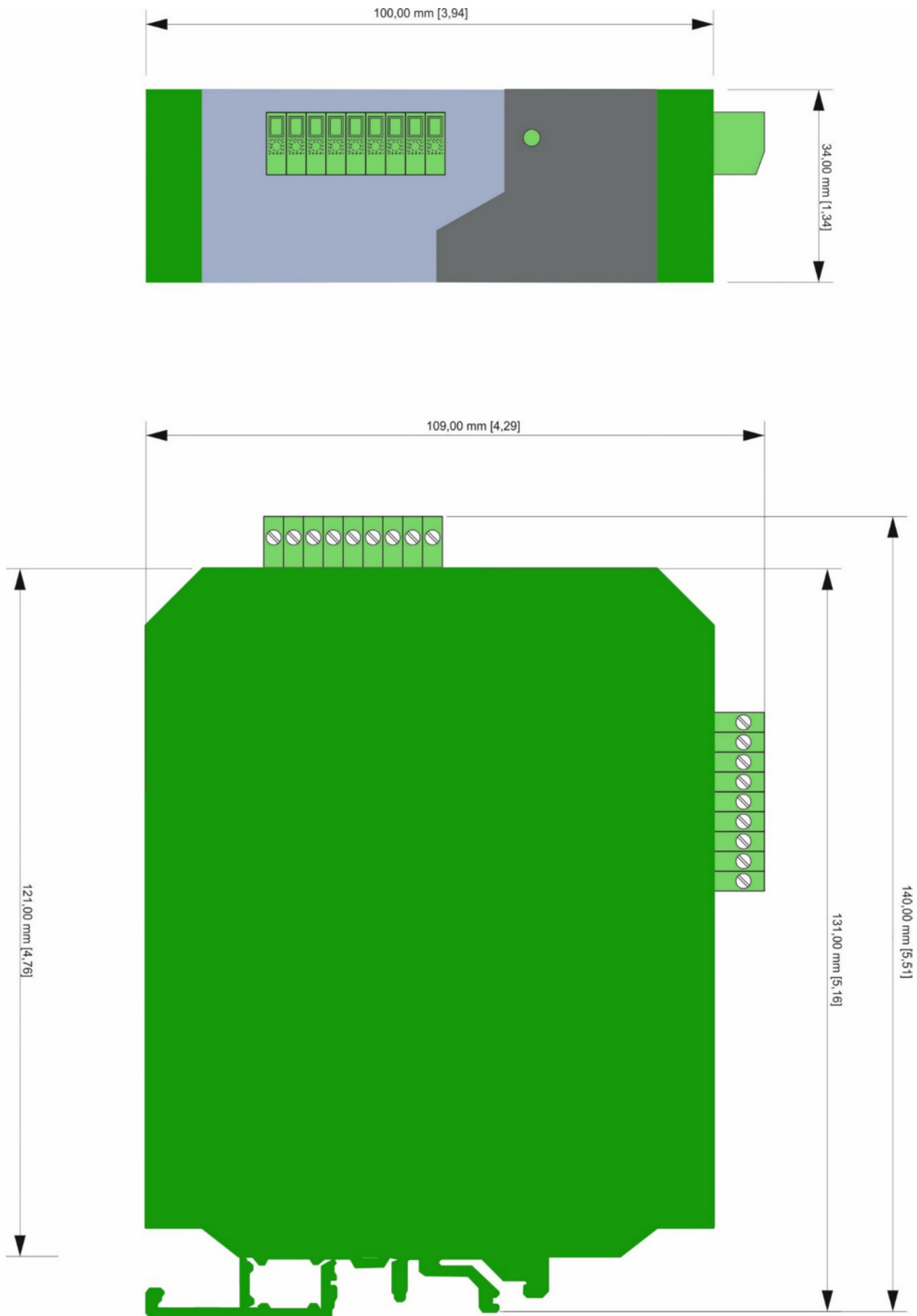

5.5. Technical Specifications

Technical Specifications:		
Connections:	Connector type:	screw terminal, 1,5 mm ² / AWG 16
Power Supply:	Input voltage: Protection circuit: Consumption:	24 VDC (18 ... 30 VDC) through IO-Link reverse polarity protection approx. 75 mA (unloaded)
Encoder supply:	Output voltage: Output current:	5 VDC and 24 VDC (approx. 1 V lower than the power supply) max. 250 mA IO Link Masterport: min. 200mA Device supply: - 75 mA <hr/> = 125 mA
SSI interface:	SSI Input- / Output: Number (channels): Configuration: Format: Frequency: Resolution: Load:	TTL differential (RS422) Clock, /Clock, Data, /Data Master or Slave Binary or Gray code 100 kHz - 2 MHz (adjustable) 10 ... 32 Bit Ri = ca. 13 kOhm
Control inputs: (only with option "CO")	Number of inputs: Format: Frequency: Reaction time: Transmission Time (IO Link): Load:	3 HTL, PNP (Low 0 ... 3 V, High 9 ... 30 V) max. 1 kHz approx.. 1ms every approx. 1 ms - (Cycle Time IO Link) max. 2 mA at 24VDC
Control outputs: (only with option "CO")	Number of outputs: Format: Output current: Reaction time: Transmission Time (IO Link)	2 5 ... 30 V (depends on the Com+ voltage), PNP max. 100 mA each output (with external Com+ supply!) min. 1 ms (Depending on "Sampling Time" and "Average Filter" setting) every approx. 1 ms - (Cycle Time IO - Link)
IO-Link:	Module / Specification: Bit rate: Port Class: Cycle time: Data width:	Device / IO Link V1.1 COM 3 (230,4 kBit / s) Typ A min. 1 ms 6 Byte (1 x 4 Byte (input data) + 1 Byte "CO" state) + 1 Byte (diagnosis data)
Indicators:	Number of indicators: Function:	1 LED 1 x green for "ready for operate" state or actual "IO Link state" (with option "CO")
Housing:	Material: Mounting: Dimensions (w x h x d): (without connectors) Dimensions (w x h x d): (inclusive connectors) Weight: Protection:	Plastic 35 mm top hat rail (according to EN 60715) 34 x 100 x 131 mm / 1.34 x 3.94 x 5.16 inches 34 x 109 x 140 mm / 1.34 x 4.65 x 5.51 inches approx.. 160 g IP20
Ambient temperature:	Operation: Storage:	-20 °C ... +60 °C resp. -4 °F ... + 140 °F not condensing -25 °C ... +70°C resp. -13 °F ... + 158 °F
Ambient conditions:	Altitude: Humidity: Degree of pollution:	max. 2000 meter above sea level max. 80% relative humidity to 30 °C / 86 °F 2
Failure rate:	MTBF in years: (continuous operation at 60 °C)	IO223: 88,0 a IO223/CO: 96,7 a
Conformity and standards:	EMC 2014/30/EU: RoHS (II) 2011/65/EU RoHS (III) 2015/863:	EN 61326-1: 2013 for industrial location EN 55011: 2016 + A1: 2017 + A11: 2020 Class A EN IEC 63000: 2018