



CA307

Data preset unit with CANopen interface

Product Features:

- **CA307** is a simple data preset unit with a BCD-coded thumbwheel switch. The unit has been designed for remote control of single parameters or process data (like position or speed) in systems using a CANopen network for communication.

* For SDO (Service Data Object) data transmission on the parameter level our alternative version **CA306** can be used.

Version:	Description:
Ca307_01a ... 01b	Diverse version updates
Ca307_01d_oi/Nov-11/ag	Safety instructions and legal Notices supplemented. Specifications updated. Dual language version separated in two stand-alone versions.

Legal notices:
All contents included in this manual are protected by the terms of use and copyrights of motrona GmbH. Any reproduction, modification, usage or publication in other electronic and printed media as well as in the internet requires prior written authorization by motrona GmbH.

Table of Contents

1. Safety Instructions and Responsibility	3
1.1. General Safety Instructions.....	3
1.2. Use according to the intended purpose	3
1.3. Installation.....	4
1.4. Cleaning, Maintenance and Service Notes	4
2. Introduction	5
3. Block diagram.....	5
4. Connections.....	6
5. Setting of the network Baud rate and sign.....	7
6. Setting of unit address and PDO transmission mode.....	8
7. The front LED.....	9
8. Transmission details.....	9
9. Dimensions.....	10
10. Technical Specifications	10

1. Safety Instructions and Responsibility

1.1. General Safety Instructions

This operation manual is a significant component of the unit and includes important rules and hints about the installation, function and usage. Non-observance can result in damage and/or impairment of the functions to the unit or the machine or even in injury to persons using the equipment!

Please read the following instructions carefully before operating the device and observe all safety and warning instructions! Keep the manual for later use.

A pertinent qualification of the respective staff is a fundamental requirement in order to use these manual. The unit must be installed, connected and put into operation by a qualified electrician.

Liability exclusion: The manufacturer is not liable for personal injury and/or damage to property and for consequential damage, due to incorrect handling, installation and operation. Further claims, due to errors in the operation manual as well as misinterpretations are excluded from liability.

In addition the manufacturer reserve the right to modify the hardware, software or operation manual at any time and without prior notice. Therefore, there might be minor differences between the unit and the descriptions in operation manual.

The raiser respectively positioner is exclusively responsible for the safety of the system and equipment where the unit will be integrated.

During installation or maintenance all general and also all country- and application-specific safety rules and standards must be observed.

If the device is used in processes, where a failure or faulty operation could damage the system or injure persons, appropriate precautions to avoid such consequences must be taken.

1.2. Use according to the intended purpose

The unit is intended exclusively for use in industrial machines, constructions and systems. Non-conforming usage does not correspond to the provisions and lies within the sole responsibility of the user. The manufacturer is not liable for damages which has arisen through unsuitable and improper use.

Please note that device may only be installed in proper form and used in a technically perfect condition (in accordance to the Technical Specifications, see chapter [10](#)).

The device is not suitable for operation in explosion-proof areas or areas which are excluded by the EN 61010-1 standard.

1.3. Installation

The device is only allowed to be installed and operated within the permissible temperature range. Please ensure an adequate ventilation and avoid all direct contact between the device and hot or aggressive gases and liquids.

Before installation or maintenance, the unit must be disconnected from all voltage-sources. Further it must be ensured that no danger can arise by touching the disconnected voltage-sources.

Devices which are supplied by AC-voltages, must be connected exclusively by switches, respectively circuit-breakers with the low voltage network. The switch or circuit-breaker must be placed as near as possible to the device and further indicated as separator.

Incoming as well as outgoing wires and wires for extra low voltages (ELV) must be separated from dangerous electrical cables (SELV circuits) by using a double resp. increased isolation.

All selected wires and isolations must be conform to the provided voltage- and temperature-ranges. Further all country- and application-specific standards, which are relevant for structure, form and quality of the wires, must be ensured. Indications about the permissible wire cross-sections for wiring are described in the Technical Specifications (see chapter [10](#)).

Before first start-up it must be ensured that all connections and wires are firmly seated and secured in the screw terminals. All (inclusively unused) terminals must be fastened by turning the relevant screws clockwise up to the stop.

Overvoltages at the connections must be limited to values in accordance to the overvoltage category II.

For placement, wiring, environmental conditions as well as shielding and earthing/grounding of the supply lines the general standards of industrial automation industry and the specific shielding instructions of the manufacturer are valid.

Please find all respective hints and rules on www.motrona.com/download.html

--> "[General EMC Rules for Wiring, Screening and Earthing]".

1.4. Cleaning, Maintenance and Service Notes

To clean the front of the unit please use only a slightly damp (not wet!), soft cloth. For the rear no cleaning is necessary. For an unscheduled, individual cleaning of the rear the maintenance staff or assembler is self-responsible.

During normal operation no maintenance is necessary. In case of unexpected problems, failures or malfunctions the device must be shipped for back to the manufacturer for checking, adjustment and reparation (if necessary). Unauthorized opening and repairing can have negative effects or failures to the protection-measures of the unit.

2. Introduction

The CA307 preset unit has been designed for remote control of single parameters (like position or speed) in systems using a CANopen network for communication.

- CA307 is standardly supplied with 6 digits (preset range: 0 ... 999 999) and built into a DIN housing.
- With supplementary ordering information "Option VZ000", the unit is supplied as version with 5 digits + sign (preset range: -99 999 ... +99 999).
- Both versions are suitable for communication on the CANopen parameter channel, accessing adjustable register codes of a network participant.

For operation on the parameter level, the special SDO version **CA306** is available.

3. Block diagram

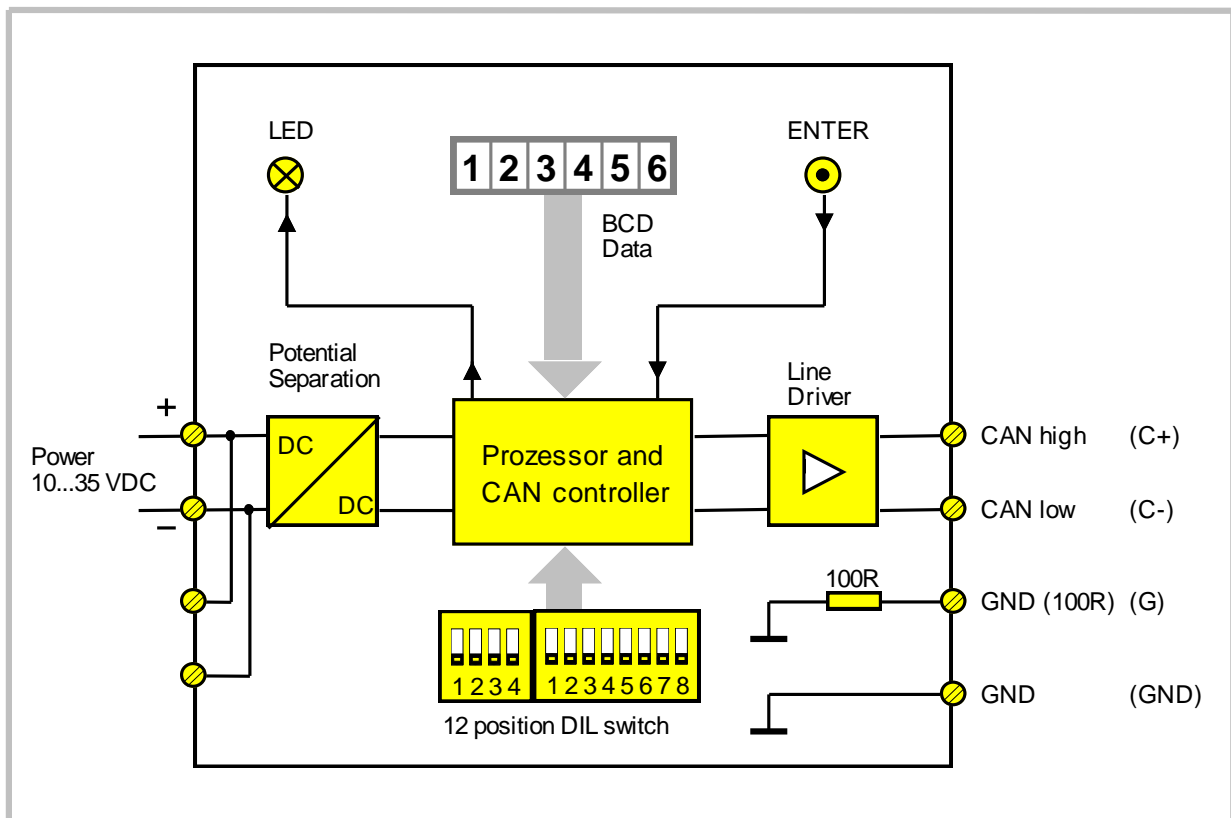

4. Connections

The screw terminals and DIL switches for setup are located on the backplane of the unit:

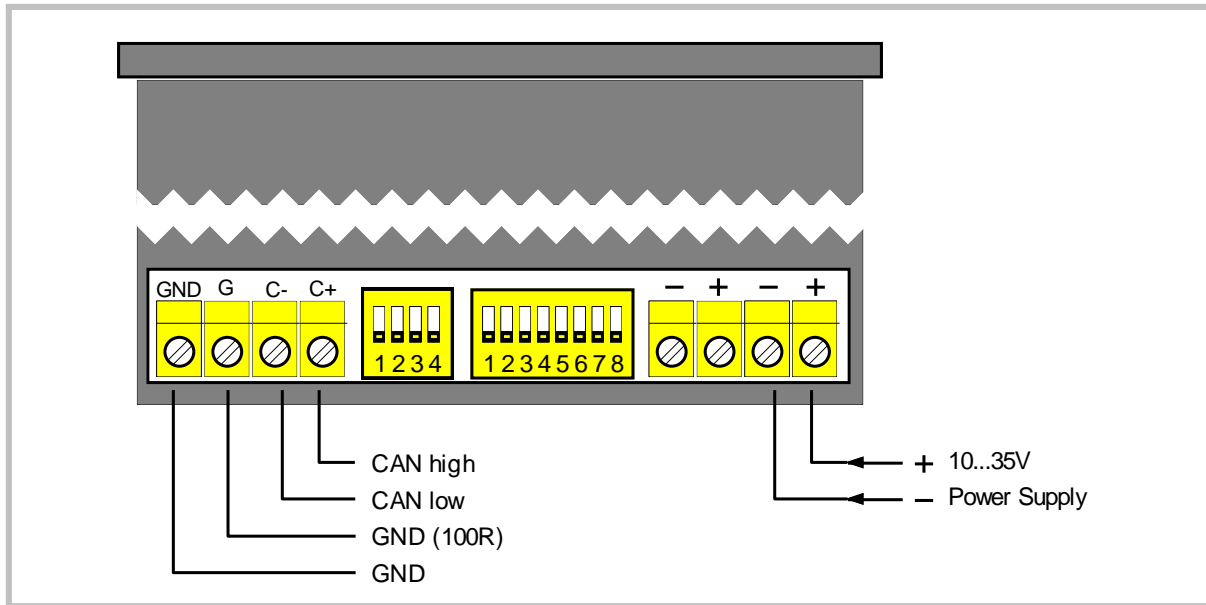

Current consumption depending on the supply voltage:

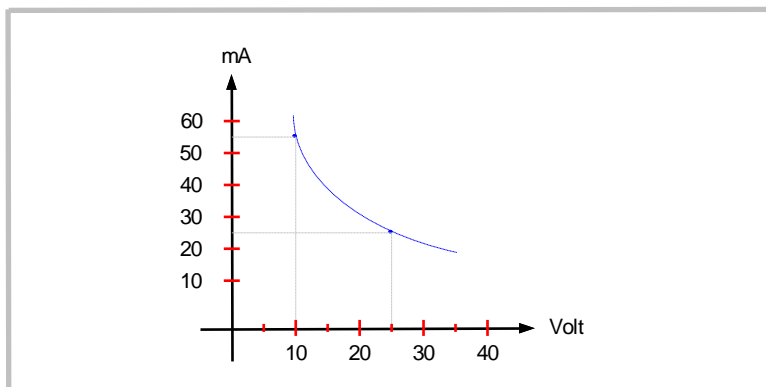

The following cables are recommended for CAN communication, depending on the cable length:

Up to 300 meters:

Cable type	LIYCY 2 x 2 x 0,5 mm ² (twisted and screened)
Resistance	≤ 40 Ω /km
Capacity	≤ 130 nF/km

More than 300 meters:

Cable type	CYPIMF 2 x 2 x 0,5 mm ² (twisted and screened)
Resistance	≤ 40 Ω /km
Capacity	≤ 60 nF/km

Please use the leads like shown:

Pair 1 (white/brown)	CAN-Low and CAN-High
Pair 2 (green/yellow)	GND

Both extreme ends of the CAN network must be terminated by a 120 Ohms resistor. The shield must be connected to earth potential.

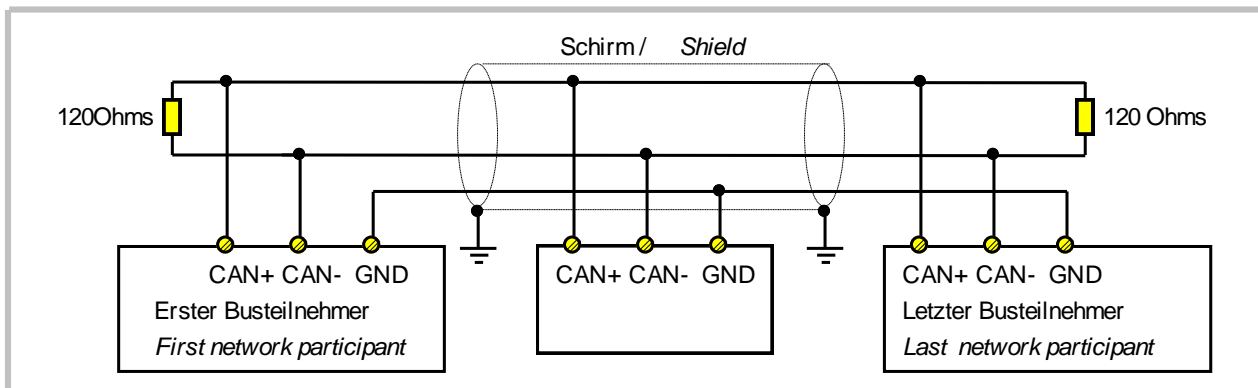

5. Setting of the network Baud rate and sign

Depending on the Baud rate, the following maximum cable length must not be exceeded:

	maximum cable length				
Baud rate (kbit / s)	50	125	250	500	1000
Cable length (m)	1000	550	250	110	25

Setting the baud rate uses positions 1 to 3 of the 4-position DIL switch on the rear:

0 0 0	=	1 000 k Baud	"0" = OFF
1 0 0	=	500 k Baud	"1" = ON
0 1 0	=	250 k Baud	
1 1 0	=	125 k Baud	
0 0 1	=	50 k Baud	
1 0 1	=	20 k Baud	
0 1 1	=	20 k Baud	
1 1 1	=	20 K Baud	

Beispiel : 500 k Baud

Example : 500 k Baud

ON
↑
OFF

Slider 4 defines the most significant digit of the front thumbwheel switches to be transmitted as a number or a sign:



The version with a sign (option **VZ000**) requires slider 4 to be “ON” at any time!

6. Setting of unit address and PDO transmission mode

Sliders 1-5 of the 8-position DIL switch will select the unit address of the target device (00-31).

Slider 6 selects synchronous transmission of data (transmission only with SYNC-Message broadcasted by the master device) or asynchronous transmission immediate after pressing ENTER-Button.

Slider 7 determines the data bytes of the PDO (process data object) the preset value is transmitted with.



Important note: All DIL switch settings are only read upon initialization and changes during normal operation will not be recognized! After change of DIL switch settings, the unit must be powered up again!

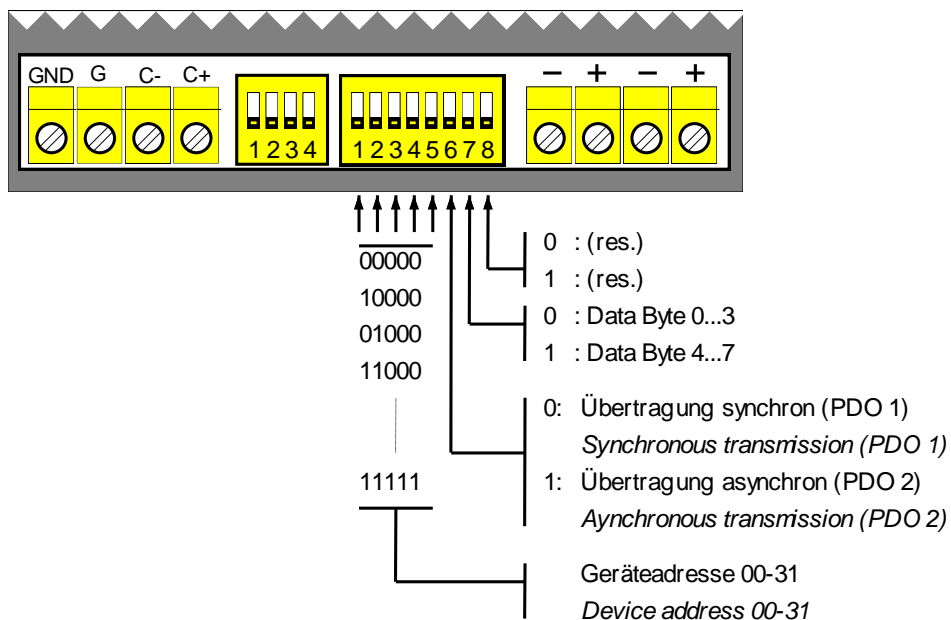

7. The front LED

This multi-purpose LED informs about the actual state of data communication, using different blinking sequences. With normal communication, this LED lights all the time. Where communication problems appear, the meaning of different blinking sequences is explained by the sub-sequent drawing::

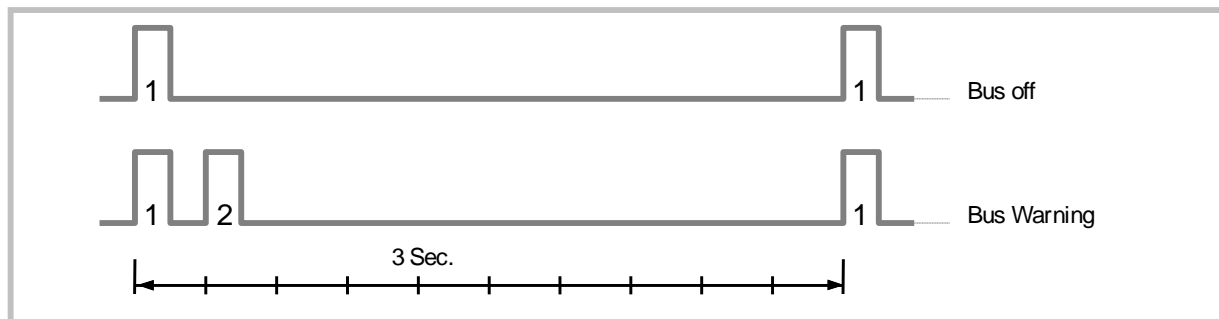

Error 2 (CAN warning) can be reset by pressing the Enter button.

To reset Error 1 it is necessary to switch off the unit and power up again.

8. Transmission details

The unit operates like a CANopen minimum capability device corresponding to CIA DS 301. It transmits the preset value as 32 bit-data by PDO (Process Data Object):

Identifier:	Data-Byte 0	Data-Byte 1	Data-Byte 2	Data-Byte 3	Data-Byte 4	Data-Byte 5	Data-Byte 6	Data-Byte 7
synchronous: 384 (180h) + unit address	(low)	32bit data		(high)	(low)	32bit data		(high)
asynchronous: 640 (280h) + unit address	(Switch 7 = OFF)			(Switch 7 = ON)				

To start the PDO communication, after power up the following NMT message (Network management) has to be sent by the CANopen master device:

Identifier:	Data-Byte 0	Data-Byte 1
0 (NMT)	01 (NMT "Start Remote Node")	Geräteadresse <i>unit adress</i> oder <i>or</i> 00 (Alle Geräte) <i>00 (all units)</i>

9. Dimensions

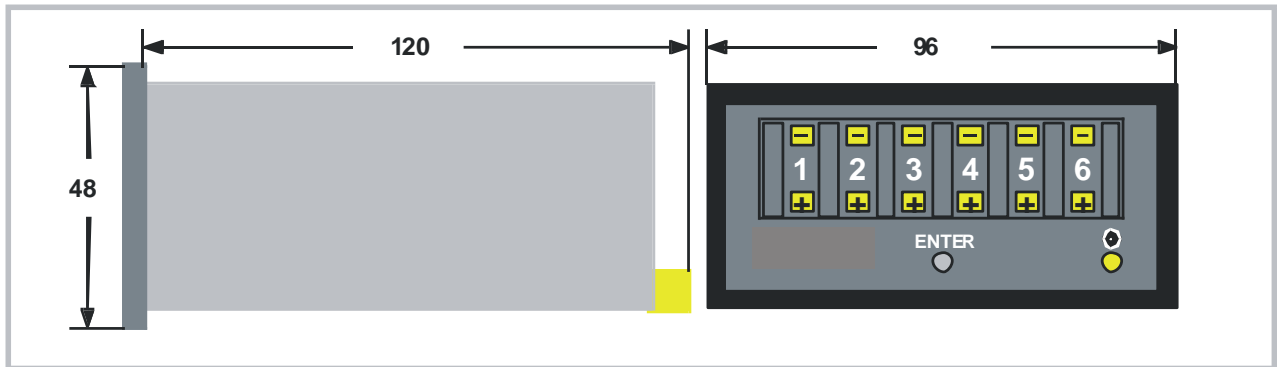

10. Technical Specifications

Power supply:	Input voltage:	10 ... 35 VDC
	Protection circuit:	reverse polarity protection
	Consumption:	approx. 30 mA (at 24 V)
	Connections:	screw terminal, 1,5 mm ² / AWG 16
Bus connection:	Communication profile:	DIN ISO 11898, CANopen (CiA DS301)
	Baud Rates (selectable):	10, 20, 50, 125, 250, 500, 1000 kbit/s
BCD switch:	Preset range:	0 ... 999 999 (standard) - 99 999 ... + 99 999 (Option VZ000)
Housing:	Material:	plastic
	Mounting:	panel
	Dimensions:	outer dimensions (w x h x d): 96 x 48 x 120 mm / 3.78 x 1.89 x 4.72 inch cut out (w x h): 92 x 43 mm / 3.62 x 1.69 inch
	Protection class:	front:* IP 40 / rear: IP20)* IP65 is available as an option
	Weight:	approx. 250 g
Temperature range:	Operation:	0 °C ... +45 °C / +32 ... +113 °F (not condensing)
	Storage:	-25 °C ... +70 °C / -13 ... +158 °F (not condensing)
Conformity & standards:	EMC 2004/108/EC:	EN 61000-6-2, EN 61000-6-3, EN 61000-6-4
	Guideline 2011/65/EU:	RoHS-conform