

GV155, GV156

Electronic Cross Switchers for Encoder Signals and Analogue Signals



- 2 x 2 Cross matrix switch for encoders RS422 (A, /A, B, /B, Z, /Z) or HTL 15-30V
- 2 x 2 Cross matrix switch for analogue signals +/- 10V
- Cascadable inputs and outputs
- Bounce-free electronic switching of all channels
- PLC compatible control inputs for source-to-target selection, signals inversion, line inhibit and for/rev selection
- Closed 19" aluminum housing, 14TE wide and 3HE high. Front connection via standard Sub-D-connectors
- Supply range 18...30VDC
- Also suitable for DIN rail mounting with option "SM150"

Operating Instructions



Safety Instructions

- This manual is an essential part of the unit and contains important hints about function, correct handling and commissioning. Non-observance can result in damage to the unit or the machine or even in injury to persons using the equipment!
- The unit must only be installed, connected and activated by a qualified electrician
- It is a must to observe all general and also all country-specific and application-specific safety standards
- When this unit is used with applications where failure or maloperation could cause damage to a machine or hazard to the operating staff, it is indispensable to meet effective precautions in order to avoid such consequences
- Regarding installation, wiring, environmental conditions, screening of cables and earthing, you must follow the general standards of industrial automation industry
- - Errors and omissions excepted –

| Version: | Description: |
|--------------------------------|--|
| GV15502B/ TJ/ Sep 03/ P1...7,2 | GV155-1 renamed to GV156 Block diagram revised |
| | |
| | |

Table of Contents

| | |
|--|---|
| 1. Block Diagram | 4 |
| 2. Applications | 5 |
| 3. Connecting Diagrams..... | 6 |
| 3.1. Encoder inputs GV155 and GV156 with TTL level | 6 |
| 3.2. Encoder inputs GV156 with HTL level (Option HTLIN1) | 6 |
| 3.3. Encoder outputs GV155 and GV156 | 6 |
| 3.4. Analogue inputs and outputs | 6 |
| 3.5. Control inputs | 7 |
| 4. Output Level Selection (GV156 only)..... | 7 |
| 5. Technical Specifications | 8 |
| 6. Dimensions..... | 9 |

1. Block Diagram

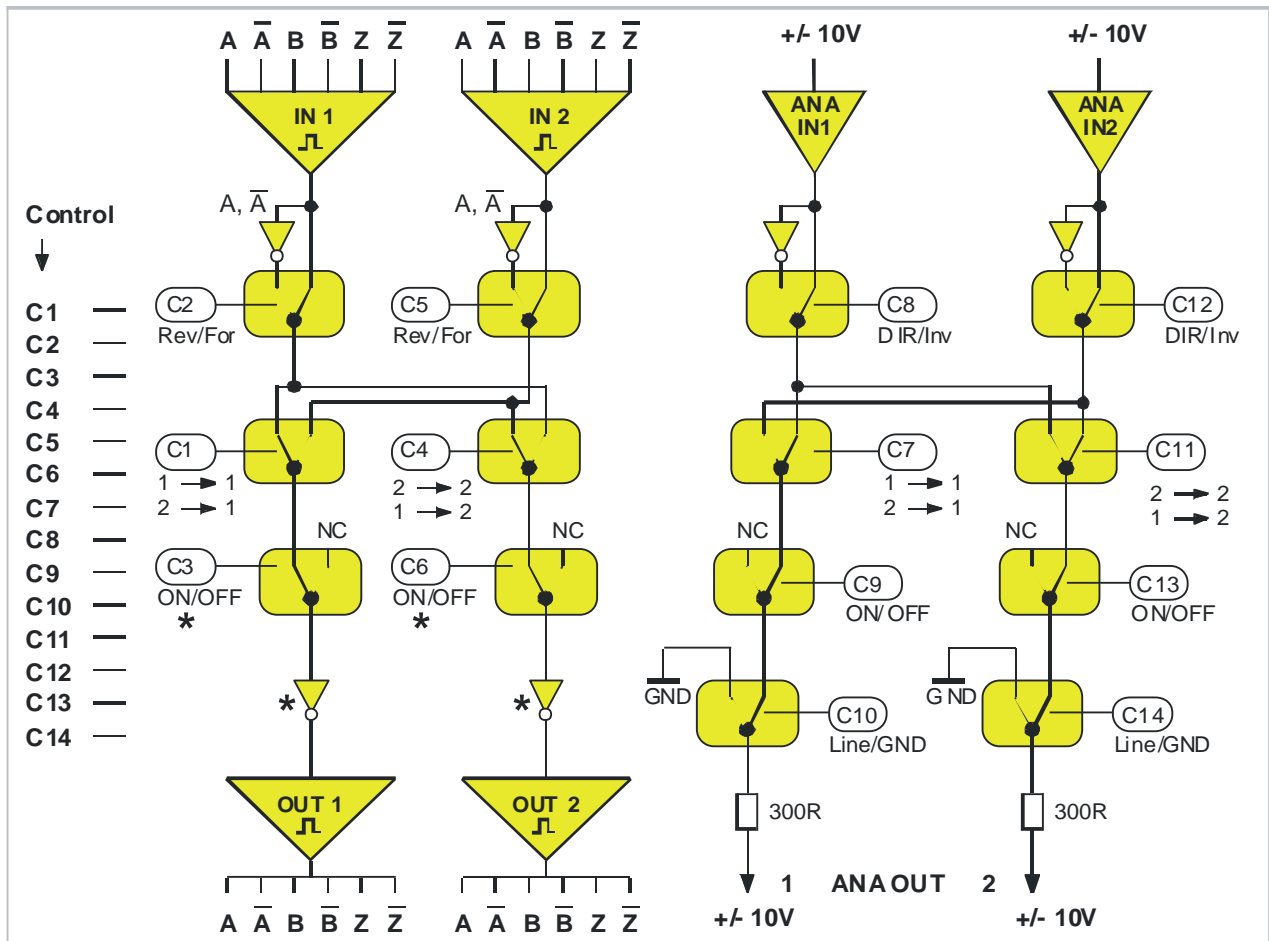

GV155: All encoder inputs and outputs are designed for TTL level (RS422 line driver signals).

GV156: Encoder inputs are available with TTL/RS422 format (standard) or with HTL (15-30V) format against ordering information "Option HTLIN1". Encoder outputs are individually adjustable to either TTL/RS422 level or HTL (15-30V) level by DIL switch setting.

*) Only with model GV155 but not with model GV156

The signal ways shown in the block diagram correspond to all control inputs in LOW or unconnected state

Control Input definition:

Low = 0...5V, High = 15...30V

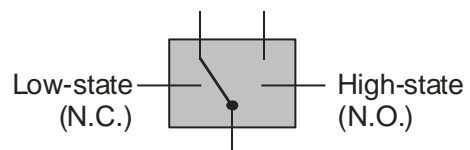

2. Applications

Typical applications can be found in drive technology and general automation, where impulse signals or analogue control lines have to be commutated between several peripheral sources and target units.

A relays circuit basically could do the same, but can become costly and also unreliable in operation, by contact overlapping, bouncing and general problems with switching of small scale signals, micro currents and high frequencies. Often, there are also unacceptable screening and wiring problems when using relays.

Use of GV155 or GV156 avoids any of these problems and allows proper and reliable switching of digital and analogue signals. There are 14 control inputs C1...C14 that can operate from mechanical switches or under PLC control.

Application Example:

Some times, in applications with electronic synchronizing of drives, there are two master drives that need to be synchronized by turns with only one slave drive, depending on the actual production. The subsequent schematic shows how to solve the analogue and digital signal commutation required:

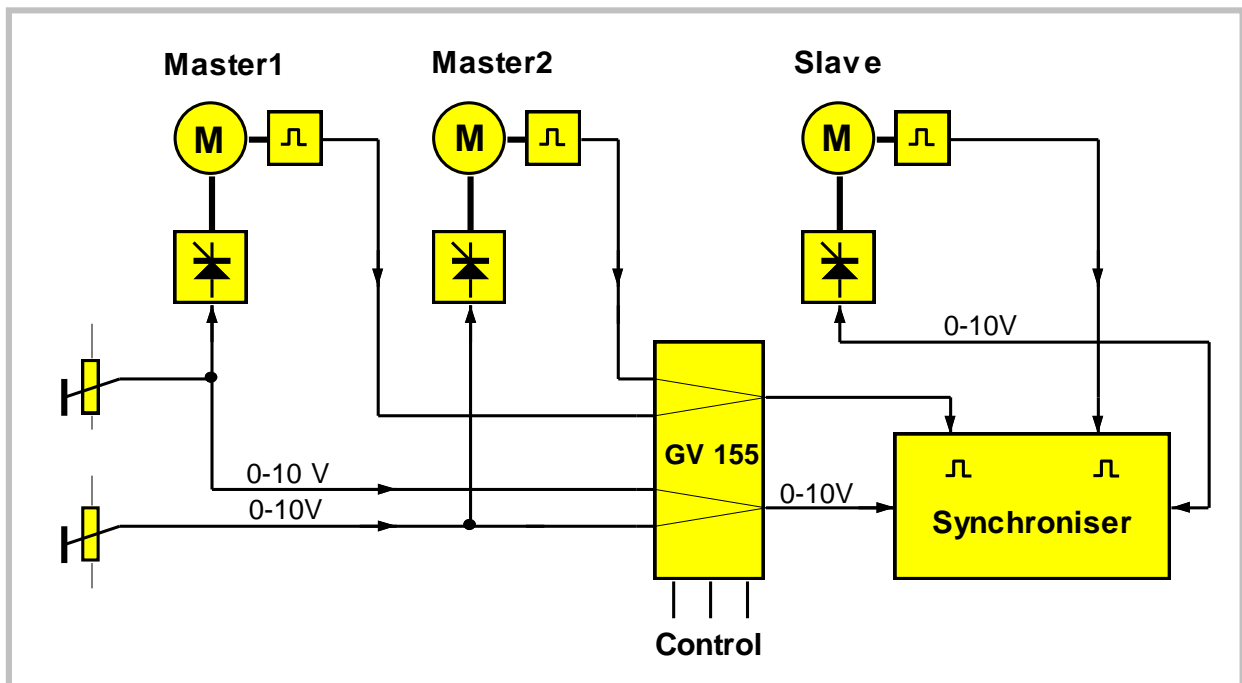

3. Connecting Diagrams

3.1. Encoder inputs GV155 and GV156 with TTL level

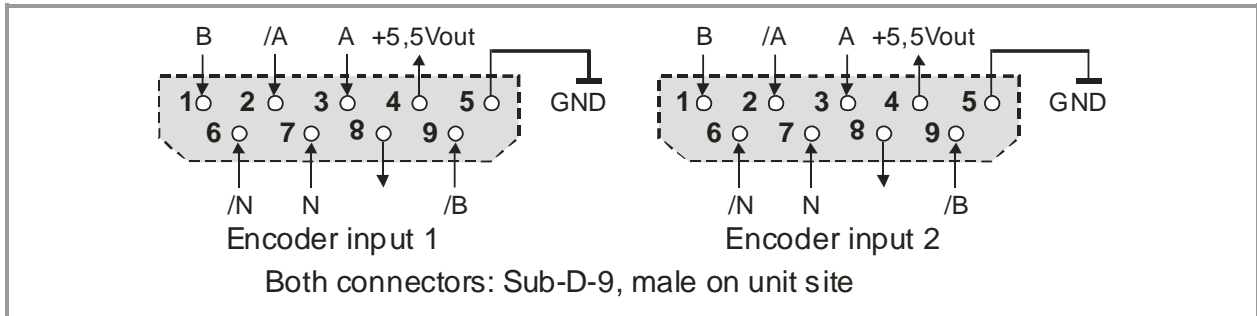

3.2. Encoder inputs GV156 with HTL level (Option HTLIN1)

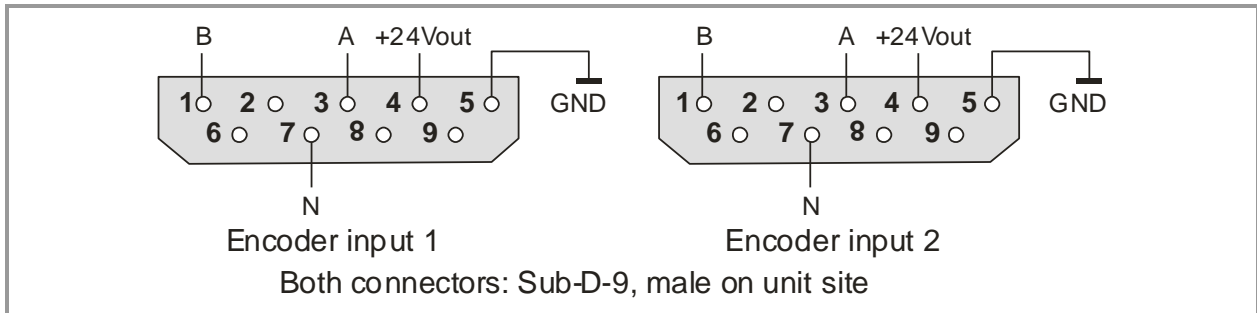

3.3. Encoder outputs GV155 and GV156

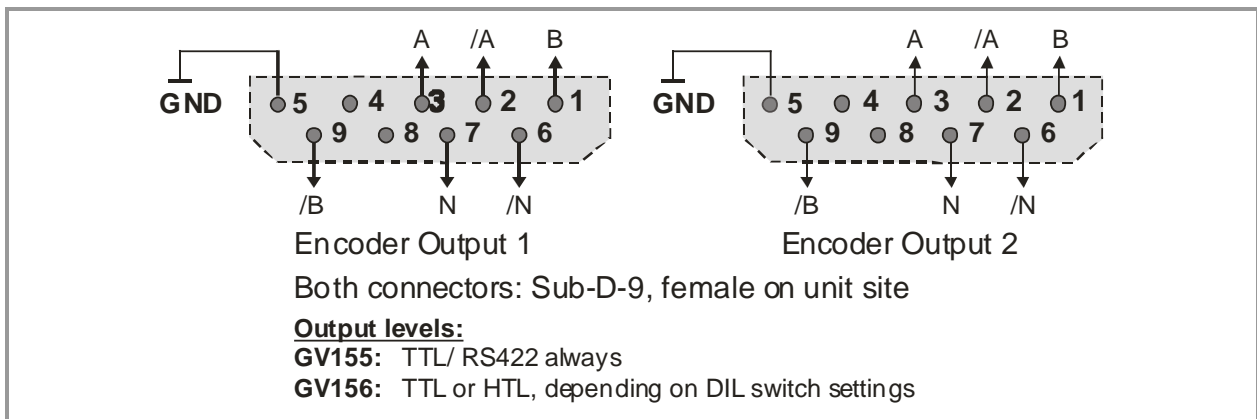

3.4. Analogue inputs and outputs

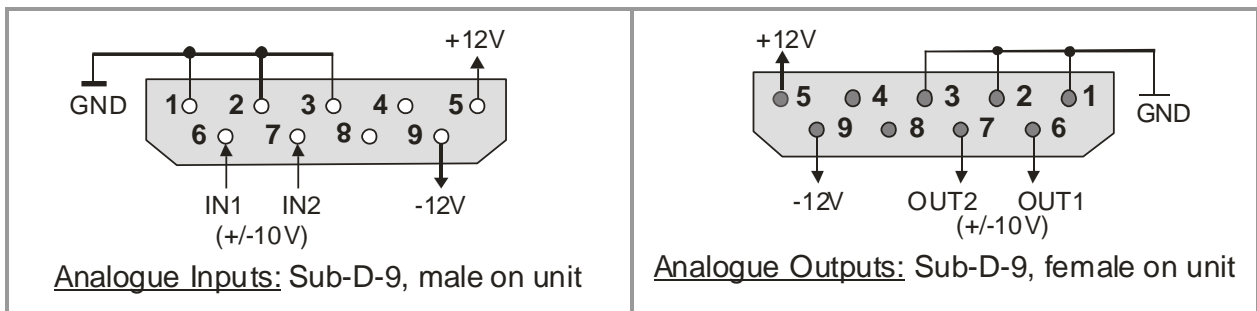

3.5. Control inputs

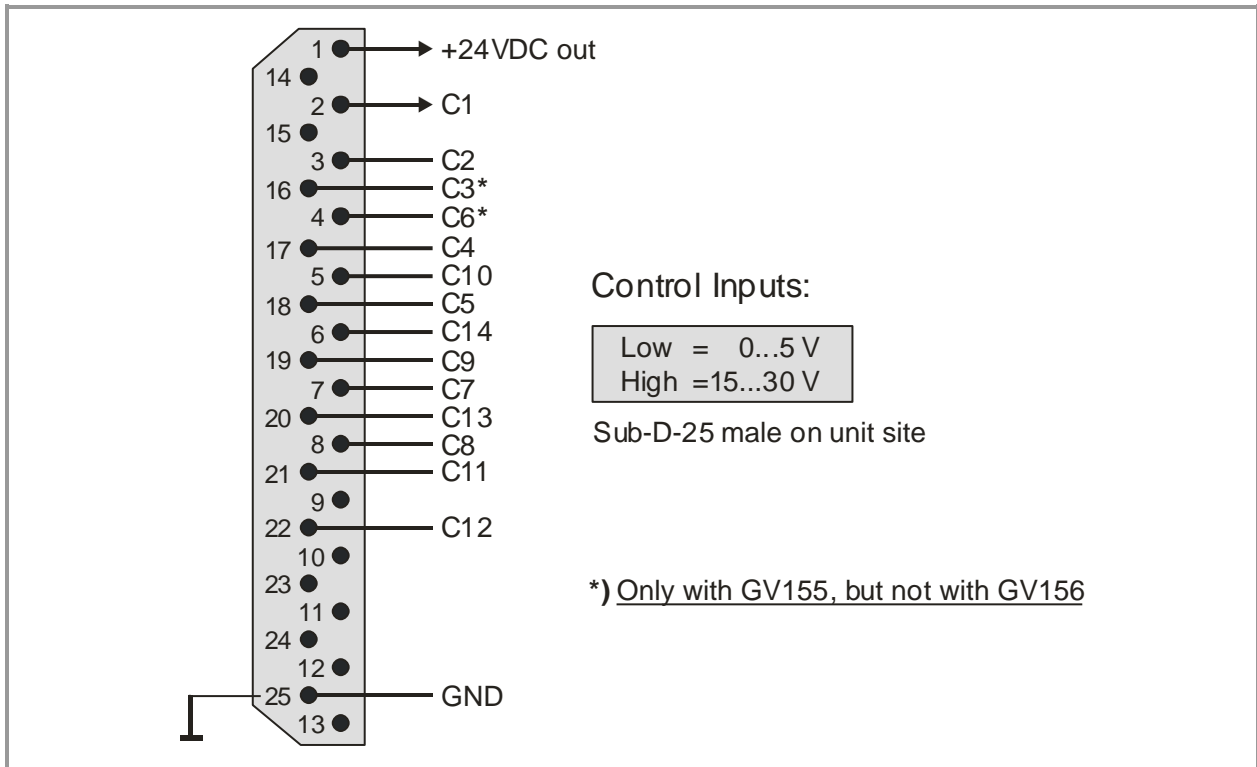

4. Output Level Selection (GV156 only)

To select the desired output level, please remove the right-hand side plate and set the DIL switch according to need:

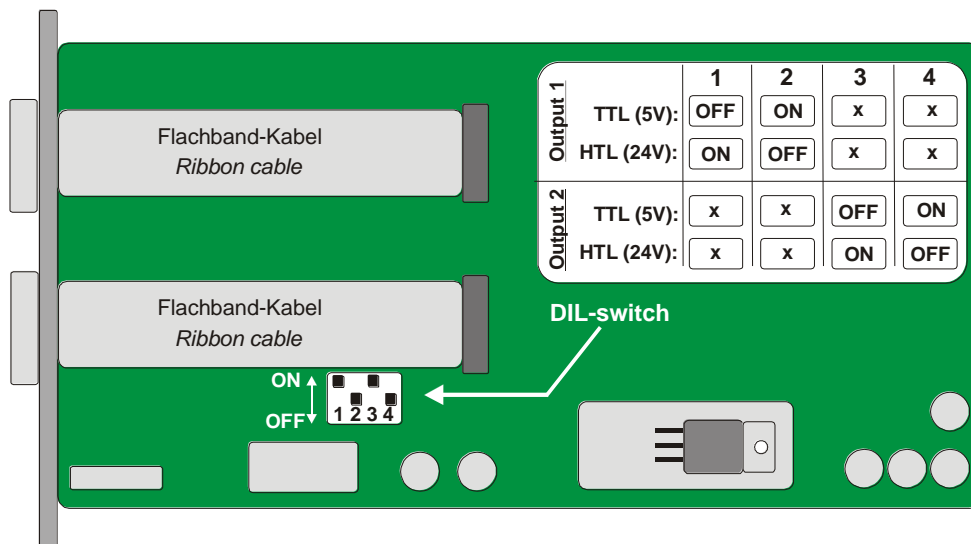

5. Technical Specifications

| | | |
|-----------------------------|---|------------------------------|
| Power supply | : 18...30 V DC/ 300 mA | |
| Max. encoder frequency | : 400 kHz (GV155), 300 kHz (GV156) | |
| Encoder propagation delay | : 200 ns (GV155), 700 ns (GV156) | |
| Encoder Inputs | : RS422, 5V / 10 mA (TTL) 15 –30 V / 10 mA / PNP (Option HTLIN1) | |
| Encoder Outputs | : RS422, 5V / 20 mA (GV155) 5V / 24V / 50 mA (GV156) | |
| Analogue inputs | : +/- 10V, RIN = 100 k Ω | |
| Analogue Outputs | : +/- 10V, ROUT = 300 Ω | |
| Analogue accuracy | : 0.05 % | |
| Analogue Offset drift | : 0.3 mV | |
| Control Inputs | : Low = 0...5V (or unconnected) High = 15...30V (PNP) | |
| Switch-over time | : typical 200 ns | |
| Dimensions | : see drawing | |
| Operating temperature range | : 0...45 ° (32 ... 113°F) | |
| Weight | : approx. 650 g | |
| Conformity and standards | : EMC 89/336/EEC: | EN 61000-6-2 EN 61000-6-3 |
| | LV73/23/EEC: | EN 61010-1 |

6. Dimensions

