



## SD / SA / SR 330 ... 644 series

Advanced measurement of rpm, speeds, speed ratios,  
sum, differential speeds or baking and processing times

### Product features:

- Simultaneous measuring of two independent speeds by means of incremental encoders, proximity switches or photocells
- Two encoder inputs for use with 1 or 2 or 4 channels (A, /A, B, /B), each with 0.1 Hz ... 1 MHz of counting range and individual scaling
- Selectable operating modes for RPM, speed, baking time (reciprocal speed), summing or differential speed, speed ratios and percentage difference
- 4 speed presets with high-speed power transistor outputs
- Models with relay outputs or front thumbwheel switches are available

### Available devices:

**SD variants:** 4 programmable presets and outputs, RS 232 interface

**SA variants:** 4 programmable presets and outputs, RS 232 interface and analogue output

**SR variants:** 4 programmable presets and outputs, RS 232 interface and RS485 interface

Version:	Description:
SD34002a/Mrz10/af/hk	First final sales version
SD34002b/Dez11/sm	conformation of the type designation
SD34002c/Feb12/sm	Correction of the parameter-values and code listings. Parameter listing for SD/SA/SR x3x added.
SD34002d/June12/pp	Corrected images in chapter 1 and 8.2
SD34002e/Sept12/pp	Correction of examples for parameter F06.075
SD34002f/Jan13/af/nw	Correction of parameter F03.030, F04.042 and F06.066
SD34002g/Sept13/tj/nw	Extension: Advice for encoder inputs
Sd340_02h_oi/Sept-15/ag	<ul style="list-style-type: none"> <li>- smaller corrections and design updates</li> <li>- chapter 1. „Safety Instructions and Responsibility“ added</li> <li>- Footnote for „Output Lock“ added (see on page 40 „F06.073“)</li> <li>- Supplementation to „Start-up Mode 1 &amp; 2“ (see pages 33 and 36)</li> <li>- „Technical specifications“ updated and „Legal notices“ supplemented</li> <li>- Analog out 3.7: notice added „only V or mA (not both together)“</li> <li>- Analog out parameter F09.101: notice and setting example added</li> </ul>

Legal notices:
<p>All contents included in this manual are protected by the terms of use and copyrights of motrona GmbH. Any reproduction, modification, usage or publication in other electronic and printed media as well as in the internet requires prior written authorization by motrona GmbH.</p>

# Table of Contents

<b>1.</b>	<b>Safety Instructions and Responsibility .....</b>	<b>4</b>
1.1	General Safety Instructions.....	4
1.2	Use according to the intended purpose.....	4
1.3	Installation.....	5
1.4	Cleaning, Maintenance and Service Notes .....	5
<b>2.</b>	<b>Available Models .....</b>	<b>6</b>
<b>3.</b>	<b>Introduction.....</b>	<b>8</b>
<b>4.</b>	<b>Electrical Connections.....</b>	<b>9</b>
4.1.	Power Supply .....	11
4.2.	Auxiliary Outputs for Encoder Supply.....	11
4.3.	Impulse Inputs for Incremental Encoders .....	11
4.4.	Control Inputs Cont.1 – Cont.4.....	11
4.5.	Switching Outputs K1 – K4.....	12
4.6.	Serial Interface .....	12
4.7.	Fast Analogue Output (SA models only).....	12
<b>5.</b>	<b>Operating Modes of the Counter.....</b>	<b>13</b>
5.1.	“Single Mode” (encoder 1 only): <u>F02.004 = 0</u> .....	15
5.2.	Dual Mode (encoder1 and encoder 2 independently): <u>F02.004 = 1</u> .....	16
5.3.	Sum Mode (encoder 1 + encoder 2): <u>F02.004 = 2</u> .....	17
5.4.	Differential Mode (encoder 1 - encoder 2): <u>F02.004 = 3</u> .....	18
5.5.	Product of Two Speeds (encoder 1 x encoder 2): <u>F02.004 = 4</u> .....	19
5.6.	Ratio of two Speeds: <u>F02.004 = 5 or 6</u> .....	20
5.7.	Percentage Speed Difference: <u>F02.004 = 7 or 8</u> .....	21
<b>6.</b>	<b>Keypad Operation.....</b>	<b>22</b>
6.1.	Normal Operation .....	22
6.2.	General Setup Procedure .....	22
6.3.	Direct Fast Access to Presets.....	23
6.4.	Change of Parameter Values on the Numeric Level .....	24
6.5.	Code Protection against Unauthorized Keypad Access .....	25
6.6.	Return from the Programming Levels and Time-Out Function .....	25
6.7.	Reset all Parameters to Factory Default Values .....	25
<b>7.</b>	<b>Menu Structure and Description of Parameters .....</b>	<b>26</b>
7.1.	Summary of the Menu .....	26
7.2.	Description of the Parameters .....	29
<b>8.</b>	<b>Practical Examples for Setup and Scaling .....</b>	<b>47</b>
8.1.	Settings for the Example a) of Chapter 5.1 (Speed Display).....	47
8.2.	Settings for the Example b) of Chapter 5.1 (Baking Time).....	47
8.3.	Settings for Example "Differential Speed" of Chapter 5.4.....	48
8.4.	Example for Use of the Filter.....	49
<b>9.</b>	<b>Appendix for models SD/SA/SR 6xx.....</b>	<b>50</b>
9.1.	Relay Outputs.....	50
9.2.	Front Thumbwheel Switches.....	50
9.3.	Specific Parameters for Units with Thumbwheel Switches .....	51
<b>10.</b>	<b>Appendix: Serial Communication Details .....</b>	<b>53</b>
10.1.	Setup of the Counter by PC .....	53
10.2.	Automatic and Cyclic Data Transmission.....	54
10.3.	Communication Protocol .....	54
10.4.	Serial Register Codes.....	56
<b>11.</b>	<b>Technical specifications.....</b>	<b>61</b>
<b>12.</b>	<b>Dimensions .....</b>	<b>63</b>
12.1.	Models 340:.....	63
12.2.	Models 640 to 644:.....	64

# 1. Safety Instructions and Responsibility

## 1.1 General Safety Instructions

This operation manual is a significant component of the unit and includes important rules and hints about the installation, function and usage. Non-observance can result in damage and/or impairment of the functions to the unit or the machine or even in injury to persons using the equipment!

**Please read the following instructions carefully before operating the device and observe all safety and warning instructions! Keep the manual for later use.**

A pertinent qualification of the respective staff is a fundamental requirement in order to use these manual. The unit must be installed, connected and put into operation by a qualified electrician.

**Liability exclusion:** The manufacturer is not liable for personal injury and/or damage to property and for consequential damage, due to incorrect handling, installation and operation. Further claims, due to errors in the operation manual as well as misinterpretations are excluded from liability.

In addition the manufacturer reserve the right to modify the hardware, software or operation manual at any time and without prior notice. Therefore, there might be minor differences between the unit and the descriptions in operation manual.

The raiser respectively positioner is exclusively responsible for the safety of the system and equipment where the unit will be integrated.

During installation or maintenance all general and also all country- and application-specific safety rules and standards must be observed.

If the device is used in processes, where a failure or faulty operation could damage the system or injure persons, appropriate precautions to avoid such consequences must be taken.

## 1.2 Use according to the intended purpose

The unit is intended exclusively for use in industrial machines, constructions and systems. Non-conforming usage does not correspond to the provisions and lies within the sole responsibility of the user. The manufacturer is not liable for damages which has arisen through unsuitable and improper use.

Please note that device may only be installed in proper form and used in a technically perfect condition (in accordance to the Technical Specifications, see chapter [11](#)). The device is not suitable for operation in explosion-proof areas or areas which are excluded by the EN 61010-1 standard.

## 1.3 Installation

The device is only allowed to be installed and operated within the permissible temperature range. Please ensure an adequate ventilation and avoid all direct contact between the device and hot or aggressive gases and liquids.

Before installation or maintenance, the unit must be disconnected from all voltage-sources. Further it must be ensured that no danger can arise by touching the disconnected voltage-sources.

Devices which are supplied by AC-voltages, must be connected exclusively by switches, respectively circuit-breakers with the low voltage network. The switch or circuit-breaker must be placed as near as possible to the device and further indicated as separator.

Incoming as well as outgoing wires and wires for extra low voltages (ELV) must be separated from dangerous electrical cables (SELV circuits) by using a double resp. increased isolation.

All selected wires and isolations must be conform to the provided voltage- and temperature-ranges. Further all country- and application-specific standards, which are relevant for structure, form and quality of the wires, must be ensured. Indications about the permissible wire cross-sections for wiring are described in the Technical Specifications (see chapter [11](#)).

Before first start-up it must be ensured that all connections and wires are firmly seated and secured in the screw terminals. All (inclusively unused) terminals must be fastened by turning the relevant screws clockwise up to the stop.

Overvoltages at the connections must be limited to values in accordance to the overvoltage category II.

For placement, wiring, environmental conditions as well as shielding and earthing/grounding of the supply lines the general standards of industrial automation industry and the specific shielding instructions of the manufacturer are valid. Please find all respective hints and rules on [www.motrona.com/download.html](http://www.motrona.com/download.html) --> "[General EMC Rules for Wiring, Screening and Earthing]" .

## 1.4 Cleaning, Maintenance and Service Notes

To clean the front of the unit please use only a slightly damp (not wet!), soft cloth. For the rear no cleaning is necessary. For an unscheduled, individual cleaning of the rear the maintenance staff or assembler is self-responsible.

During normal operation no maintenance is necessary. In case of unexpected problems, failures or malfunctions the device must be shipped for back to the manufacturer for checking, adjustment and reparation (if necessary). Unauthorized opening and repairing can have negative effects or failures to the protection-measures of the unit.

## 2. Available Models

The speed meters of this series include a range of models with similar functions and properties, but with different housings, outputs and interfaces.

All models are equipped with 4 programmable presets and 4 fast-switching transistor outputs as well as a serial RS232 interface.

**SD models** provide this basic configuration only.

**SA models** provide an additional high-speed analogue output

**SR models** provide an additional RS485 communication interface

All further properties of the models are fully identical. The range of available models also includes units with relay outputs and front thumbwheel switches.

The following table explains the details of type designation and the possible options:

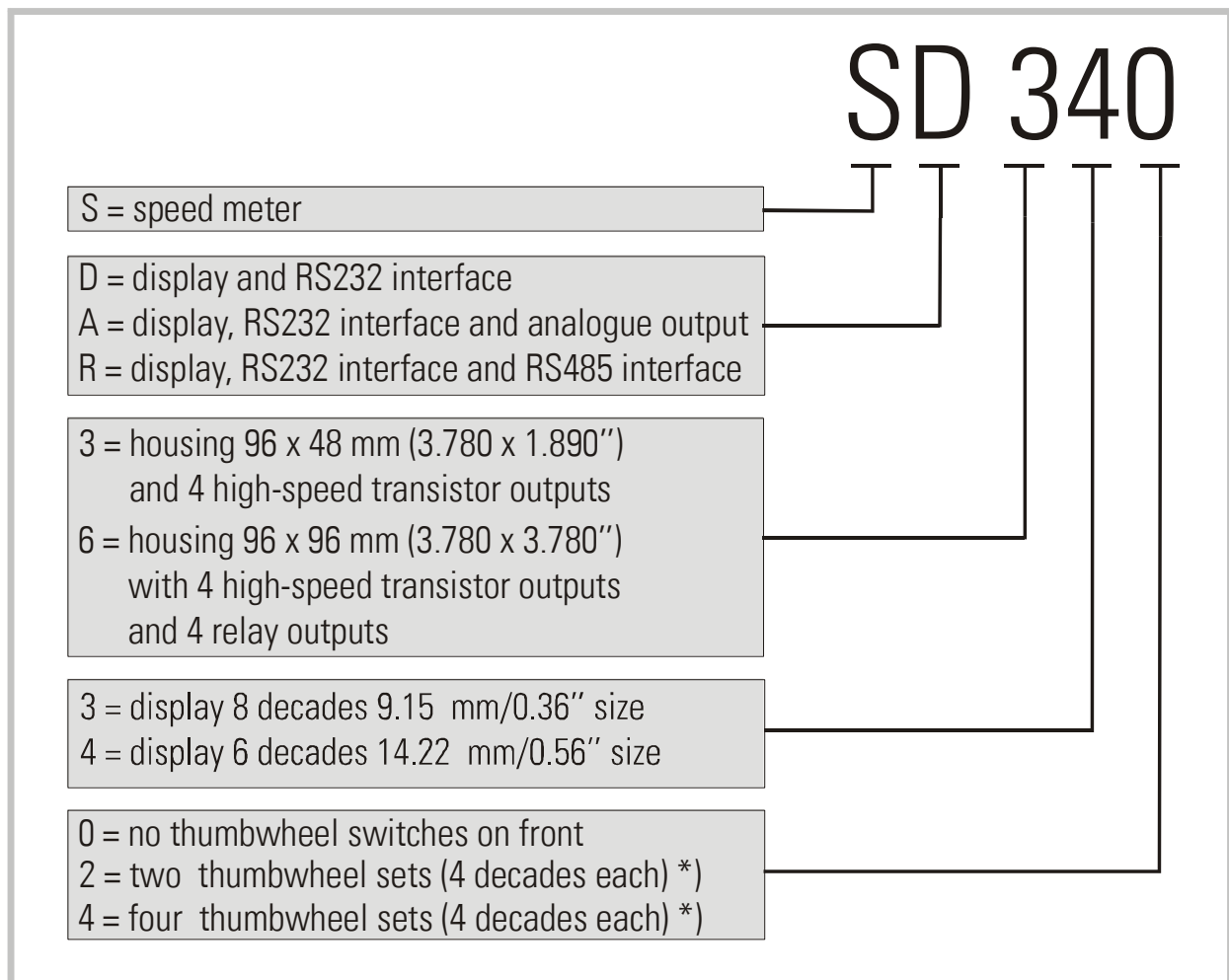

\*) Other combinations are possible, see section [9.2](#)

The following models are available:



SD 340, SA 340, SR 340



SD 640, SA 640, SR 640



SD 642, SA 642, SR 642

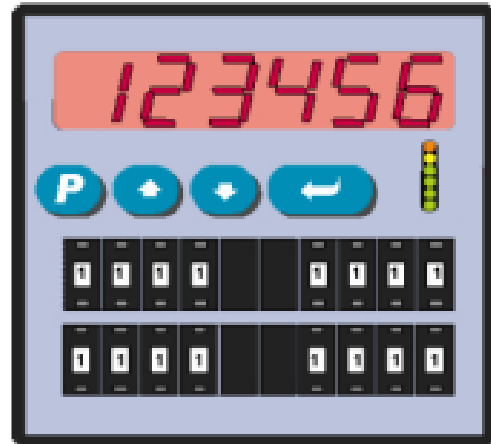

SD 644, SA 644, SR 644

Customer specified numbers and/or combinations of the front thumbwheels, see in section [9.2](#)

### 3. Introduction

Speed meters of series SD, SA and SR have been designed to close a gap with multiple speed measuring applications, which cannot be accomplished by normal industrial tachometers.

A continual demand for increasing production speeds and higher precision at the same time results in counting frequencies exceeding the conventional frequency range.

Particularly with fast running machines it is most important to also get fast response of the switching outputs or the analogue output.

Many applications require to evaluate the signals of two incremental measuring systems, and to compare the results with respect to the sum or the difference or the ratio of the two speeds. The latter is e.g. required to indicate the diameter of a winding roll by sensing the line speed and the roll rpm.

Other applications with food processing or process technology need to record the speed in a reciprocal way (i.e. baking or processing time calculated from the actual speed)

And still there exist applications where the use of traditional thumbwheel switches offers real advantages compared to keypad and menu operations.

These are some of the reasons why the new indicator series SD / SA / SR have been designed.



- This manual at first provides all basic instructions for operation of the counter models presented in the previous chapter
- For operation of relay outputs and thumbwheel switches (if applicable) please observe the supplementary instructions given in the appendix
- For easy PC setup and PC communication with SD and SA counters, please use our "OS32" operator software (free of charge, download from our homepage [www.motrona.com](http://www.motrona.com))
- Where you like to have free serial access to the unit by PLC or IPC or by a remote operator terminal, please observe the serial protocol details described in our separate manual "Serpro"
- Subsequently the manual uses the expression SD340 as a replacement for all available models. However, statements are fully valid for the other models too, except where especially remarked.



# 4. Electrical Connections

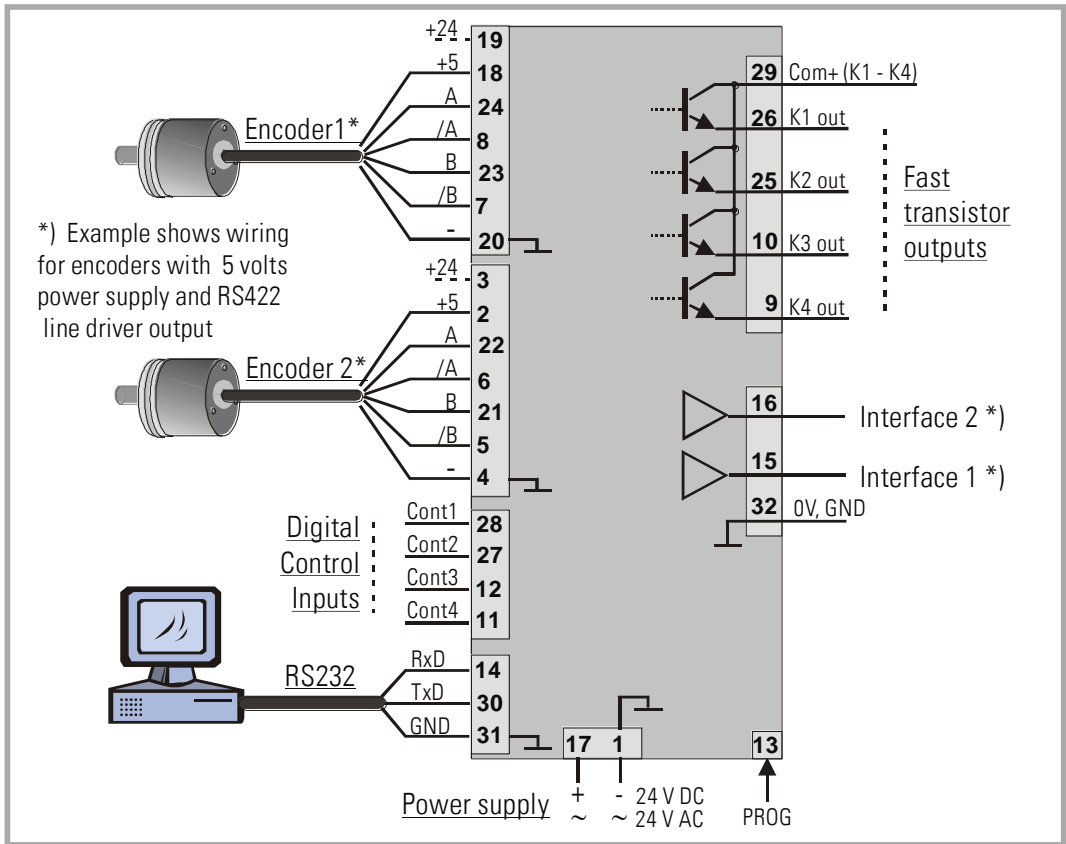
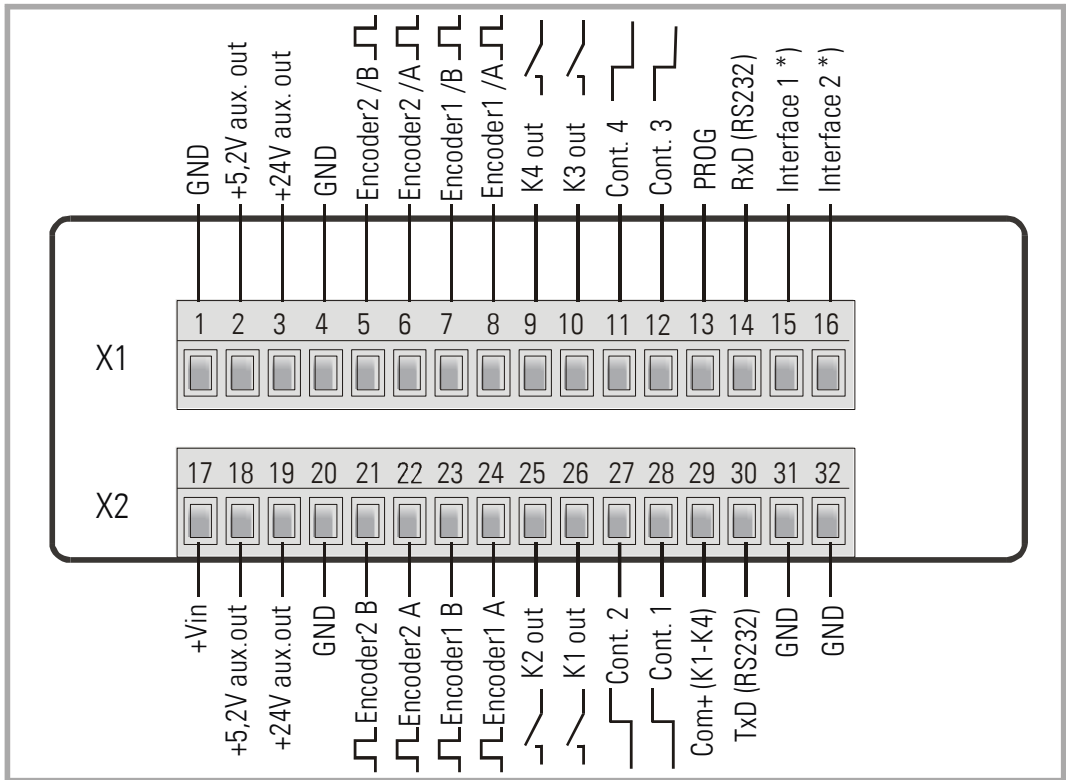

	Series "SD"	Series "SA"	Series "SR"
*) Interface 1:	- no function -	Analogue output 0/4 - 20 mA	RS 485, B (-)
*) Interface 2:	- no function -	Analogue output +/- 10 V	RS 485, A (+)

Terminal	Name	Function
01	GND	Common Ground Potential (0V)
02	+5,2V out	Aux. output 5.2V/150 mA for encoder supply
03	+24V out	Aux. output 24V/120 mA for encoder supply
04	GND	Common Ground Potential (0V)
05	Encoder 2, /B	Encoder 2, channel /B (B inverted)
06	Encoder 2, /A	Encoder 2, channel /A (A inverted)
07	Encoder 1, /B	Encoder 1, channel /B (B inverted)
08	Encoder 1, /A	Encoder 1, channel /A (A inverted)
09	K4 out	Output K4, transistor PNP 30 volts, 350 mA
10	K3 out	Output K3, transistor PNP 30 volts, 350 mA
11	Cont.4	Digital control input
12	Cont.3	Digital control input
13	(PROG)	(for download of new firmware only, not for general use)
14	RxD	Serial RS232 interface, input (Receive Data)
15	Interface 1	SD 340: n. c. (no function) SA 340: Analogue current output 0/4 - 20 mA SR 340: Serial RS385 interface, line B (-)
16	Interface 2	SD 340: n. c. (no function) SA 340: Analogue voltage output +/- 10 V SR 340: Serial RS485 interface, line A (+)
17	+Vin	Power supply input, +17 – 40 VDC or 24 VAC
18	+5,2V out	Aux. output 5,2V/150 mA for encoder supply
19	+24V out	Aux. output 24V/120 mA for encoder supply
20	GND	Common Ground Potential (0V)
21	Encoder 2, B	Encoder 2, channel B (non-inverted)
22	Encoder 2, A	Encoder 2, channel A (non-inverted)
23	Encoder 1, B	Encoder 1, channel B (non-inverted)
24	Encoder 1, A	Encoder 1, channel A (non-inverted)
25	K2 out	Output K2, transistor PNP 30 volts, 350 mA
26	K1 out	Output K1, transistor PNP 30 volts, 350 mA
27	Cont.2	Digital control input
28	Cont.1	Digital control input
29	Com+ (K1-K4)	Common positive input for transistor outputs K1-K4
30	TxD	Serial RS232 interface, output (Transmit Data)
31	GND	Common Ground Potential (0V)
32	GND	Common Ground Potential (0V) for DC or AC power supply

\*) 120 mA and 150 mA are per encoder, i.e. total maximum currents are 240 mA and 300 mA

## 4.1. Power Supply

The SD340 counter accepts both, a 17 – 40 volts DC power or a 24 volts AC power (+/-10%) for supply via terminals 17 and 1. The current consumption depends on the level of the input voltage and some internal conditions; therefore it can vary in a range from 100 – 200 mA (aux. currents taken from the unit for encoder supply not included).

## 4.2. Auxiliary Outputs for Encoder Supply

Terminals 2 and 18 provide an auxiliary output with approx. +5.2 VDC (300 mA totally).  
Terminals 3 and 19 provide an auxiliary output with approx. +24 VDC (240 mA totally)

## 4.3. Impulse Inputs for Incremental Encoders

All input characteristics of the impulse inputs can be set by the parameter menu, for each of the encoders separately. Depending on the application the unit can accept single channel information (input A only without direction signal) or dual channel signals (A = step and B = direction) or quadrature information (A / B, 90°). The following settings are possible:

- Symmetric input (differential A, /A, B, /B) according to RS422 standard
- TTL inputs at a level of 3.0 to 5 volts (differential, with inverted signal)
- TTL inputs at a level of 3.0 to 5 volts (single-ended) \*)
- HTL signals at a 10 – 30 volts level  
(alternatively differential with inverted signals A, /A, B, /B, or single-ended A, B only)
- Impulses from photocells or proximity switches etc. providing a HTL level (10 – 30 volts)
- Proximity switches according to NAMUR (2-wire) standard  
(may need additional remote resistor)

\*) requires special settings of the threshold parameters, see “Special parameters F08”



All encoder input lines are internally terminated by pull-down resistors ( 8,5 kΩ ).  
Where encoders with pure NPN outputs are used, corresponding pull-up resistors must be available inside the encoder or externally to ensure proper function (1 kΩ ... 3,3 kΩ).

## 4.4. Control Inputs Cont.1 – Cont.4

These inputs can be configured for various remote functions as described in section [7.2.4](#). All control inputs require HTL level. They can be individually set to either NPN (switch to -) or PNP (switch to +) characteristics. For applications where edge-triggered action is needed, the menu allows to set the active edge (rising or falling). Control inputs also accept signals with Namur (2-wire) standard.

For reliable operation the minimum pulse width on the control inputs should be 50 µsec.

## 4.5. Switching Outputs K1 – K4

SD340 provides four presets and outputs with programmable switching characteristics.

K1 – K4 are fast-switching and short-circuit-proof transistor outputs with a switching capability of 5 – 30 volts / 350 mA each. The switching voltage of the outputs must be applied remotely to the Com+ input (terminal 29)

## 4.6. Serial Interface

The serial RS232/RS485 interfaces can be used for the following purposes:

- Set-up of the unit by PC (if desirable), by means of the OS32 PC software
- Change of parameters during operation
- Readout of actual counter or other values by PLC or PC

The figure below explains how to connect the SD340 unit and a PC using the standard Sub-D-9 serial connector, and how to connect the RS485 terminals to a PLC.

Details about serial communication are shown in chapter [10](#).

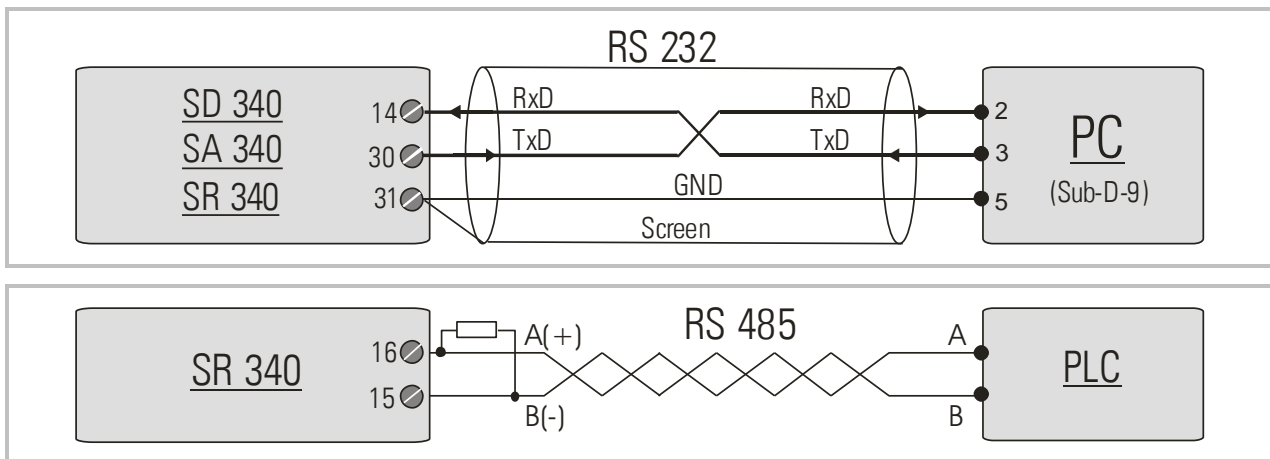

Where both, RS232 and RS485 interface are in use, you can communicate by the one or by the other, but not by both interfaces at the same time.

## 4.7. Fast Analogue Output (SA models only)

The 14 bits analogue output can be used for operation with -10 / 0 ... +10 VDC (load = 3 mA) or 0 / 4 ... 20 mA (load = 0 – 270 Ohms). All output characteristics like beginning of conversion range, output swing etc. are freely programmable via menu. The response time of the analogue output depends on the mode of measuring and the sampling times used. Please note that extensive serial communication with the unit may temporary increase the analogue response time.



**Important note: "voltage out" and "current out" must not be used together. Please do never connect mA and V simultaneously!**

## 5. Operating Modes of the Counter

For best survey, all parameters of the unit are arranged in 13 expedient groups, named "F01" - "F13". Depending on the application, only a few of these groups may be important, while all other groups may be irrelevant for your specific application.

All details about configuration and function of the parameters can be found in chapter [7](#). Practical examples for settings are shown in chapter [8](#).

This section describes possible applications and operating modes of the unit.

The operation mode can be set under parameter group F02, parameter # F02.004.



- It is possible to cycle the display between all reading modes shown in the following function tables, by pressing one of the front keys or by using one of the control inputs (you must have assigned the "display scrolling function" to one of the keys or the inputs under menu F05 to activate the scrolling of the display).
- LED L1 (red) and L2 (yellow) indicate which of the values is actually visible in display  
L1 on: the speed of encoder 1 is displayed  
L2 on: the speed of encoder 2 is displayed  
L1 and L2 on: the combined value  $[\text{encoder1}] * [\text{encoder2}]$  is displayed.
- LEDs shining continuously indicate: actual measuring value.  
LEDs blinking slowly indicate: minimum value (since last reset of the min/max memory).  
LEDs blinking fast indicate: maximum value (since last reset of the min/max memory).
- Scrolling of the display from one reading mode to another will not affect the function of the preselection outputs K1 – K4
- The analogue output (models SA) can be assigned to any of the readings accessible in the display, by a special parameter. Scrolling of the display from one reading mode to another will not affect the analogue output.
- With all operating modes the evaluation of the input frequencies occurs fully separately with use of individual scaling factors. Please observe that only integer results after the scaling operations, but no decimal positions will appear in the display. Where you like to display your result with decimals, please scale your value correspondingly higher (by factor 10, 100 or 1000) and then use a decimal point to receive the desired display value (see examples under [8.2](#))
- With all encoders providing information about the direction of rotation (e.g. quadrature encoders A/B/90°), the unit will also display a sign (positive with A leading B and negative with B leading A). Preselection values can be set for response to absolute values only (no consideration of the actual sign), or for response to the signed value. With models SA the analogue output will also change the +/- polarity in accordance with the actual sign.
- All combinations  $[\text{encoder1}] * [\text{encoder2}]$  are calculated straightaway according to the individual operating mode and the scaling factor of each channel. Please take care that the results to combine are scaled with proper and compatible dimensions (don't compare apples and oranges)

You can choose from the following operating modes:

Operating Mode F02.004	Measuring Function of the unit
0	Single mode, evaluation of encoder 1 only
1	Dual mode, individual evaluation of encoder 1 and encoder 2
2	Sum mode, [speed of encoder1] + [speed of encoder2]
3	Differential mode, [speed of encoder1] - [speed of encoder2]
4	Multiplication mode, [speed of encoder1] x [speed of encoder2]
5	Ratio mode, [speed of encoder1] : [speed of encoder2]
6	Inverse ratio mode, [speed of encoder2] : [speed of encoder1]
7	Percentage mode, [encoder1 - encoder2] : [encoder2] x 100%
8	Inverse percentage mode, [encoder2 - encoder1] : [encoder1] x 100%

Your choice of operating mode will decide how in general the two encoder frequencies have to be treated. It will not affect the scaling or the measuring characteristics or the final presentation of the result.

## 5.1. "Single Mode" (encoder 1 only): F02.004 = 0

Only the inputs of encoder 1 are active, signals on the encoder 2 inputs will not be evaluated. Besides the actual counter value, the unit also records minimum and maximum values, with regard to the last Reset of the Min/Max memory.

All 4 presets are related to the actual measuring value.

Display		L1 (red)	L2 (yellow)
1	Actual measuring value of encoder 1	statically ON	--
2	Minimum value since last min/max reset	blinking slow	--
3	Maximum value since last min/max reset	blinking fast	--

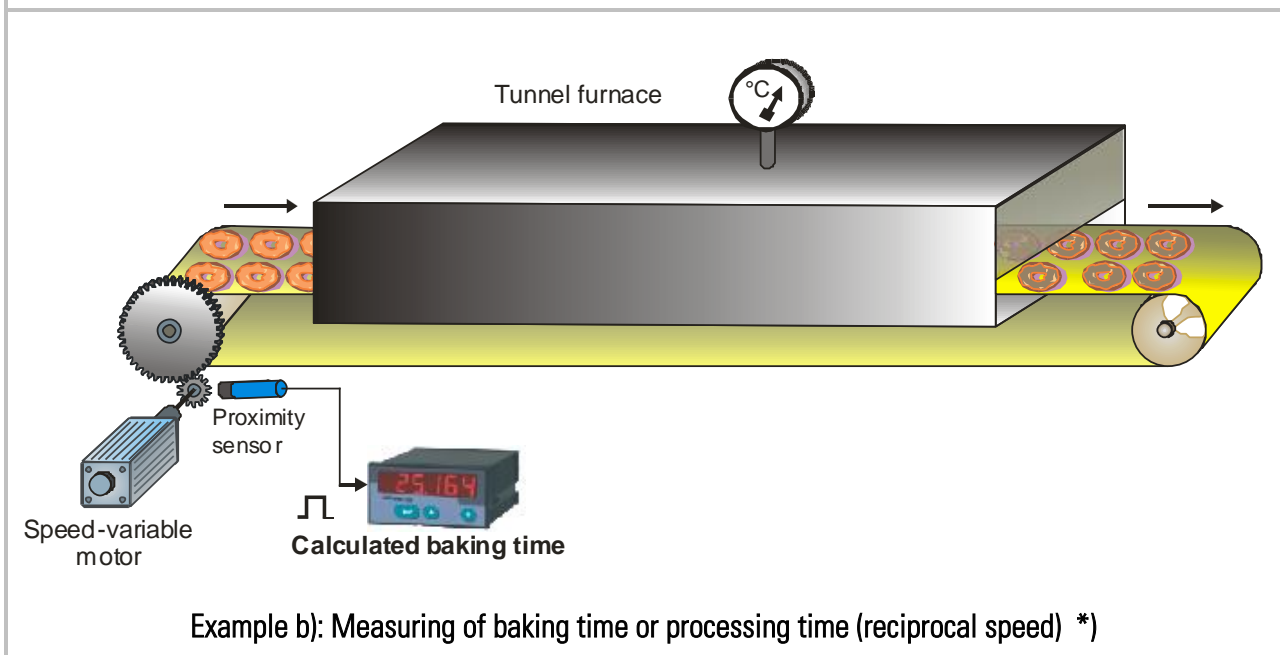
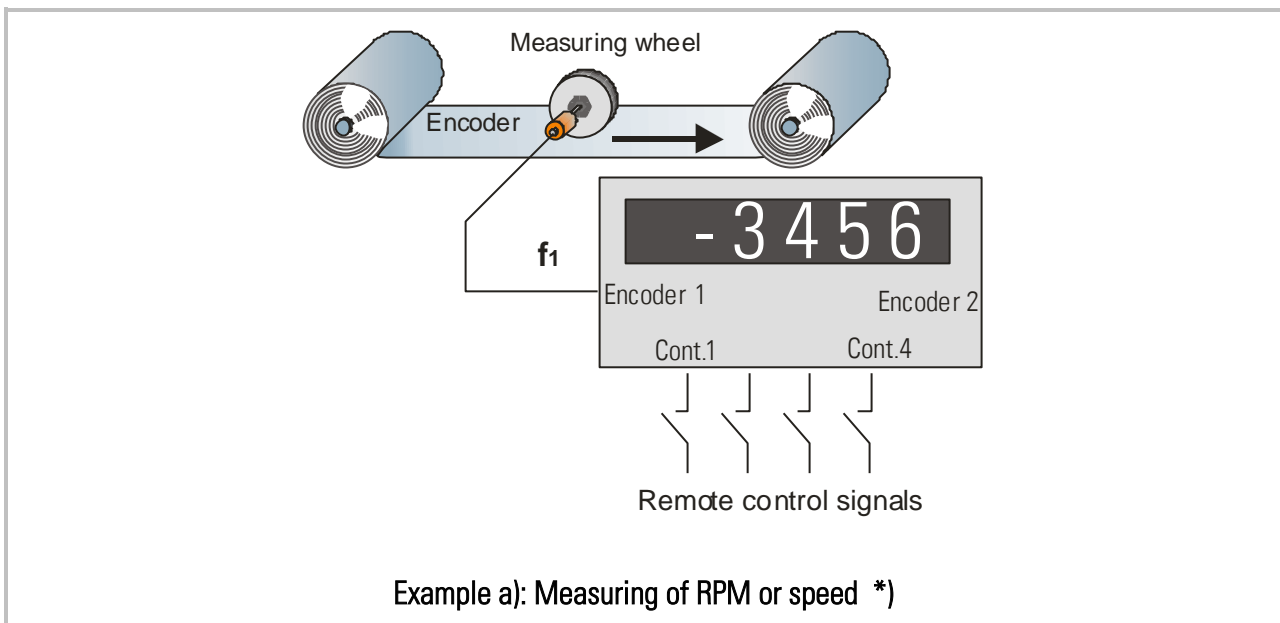

\*) For these applications you can find concrete examples of parameter settings in chapter [8](#).

## 5.2. Dual Mode (encoder1 and encoder 2 independently): F02.004 = 1

Both, encoder input 1 and encoder input 2 are active and the frequencies are evaluated independently,

Besides the actual measuring values the unit also records the minimum and maximum values of both channels, with regard to the last Reset of the Min/Max memory.

Presets K1 and K2 refer always to the measuring result of encoder 1.

Presets K3 and K4 refer always to the measuring result of encoder 2.

Display	L1 (red)	L2 (yellow)
1 Actual measuring value of encoder 1	statically ON	
2 Minimum value encoder 1 since last min/max reset	blinking slow	
3 Maximum value encoder 1 since last min/max reset	blinking fast	
4 Actual measuring value of encoder 2		statically ON
5 Minimum value encoder 2 since last min/max reset		blinking slow
6 Maximum value encoder 2 since last min/max reset		blinking fast

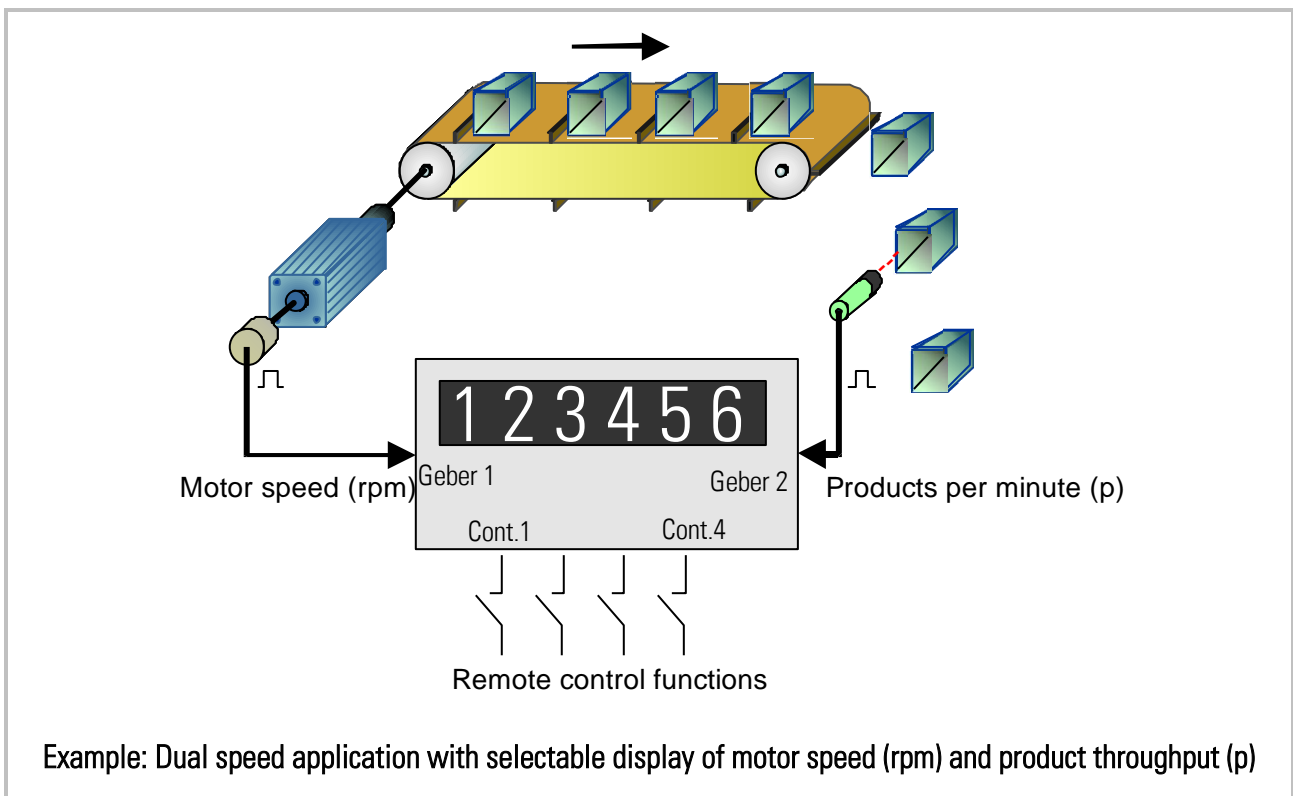



### 5.3. Sum Mode (encoder 1 + encoder 2): F02.004 = 2

Both inputs, encoder 1 and encoder 2, are active. From both values the unit forms the sum, with consideration of the individual scaling of each channel. The final result can once more be scaled into user-friendly engineering units by means of the special scaling parameters in parameter group F02.

Besides the actual speeds and the sum value, the unit also records minimum and maximum values of the sum.

Preset K1 is related to the absolute speed of encoder 1.

Preset K2 is related to the absolute speed of encoder 2.

Presets K3 and K4 are related to the actual sum of the speeds (encoder 1 + encoder 2)

	Display	L1 (red)	L2 (yellow)
1	Actual sum [speed encoder1] + [speed encoder2]	statically ON	statically ON
2	Minimum sum value since last min/max reset	blinking slow	blinking slow
3	Maximum sum value since last min/max reset	blinking fast	blinking fast
4	Actual measuring value of encoder 1	statically ON	---
5	Actual measuring value of encoder 2	---	statically ON

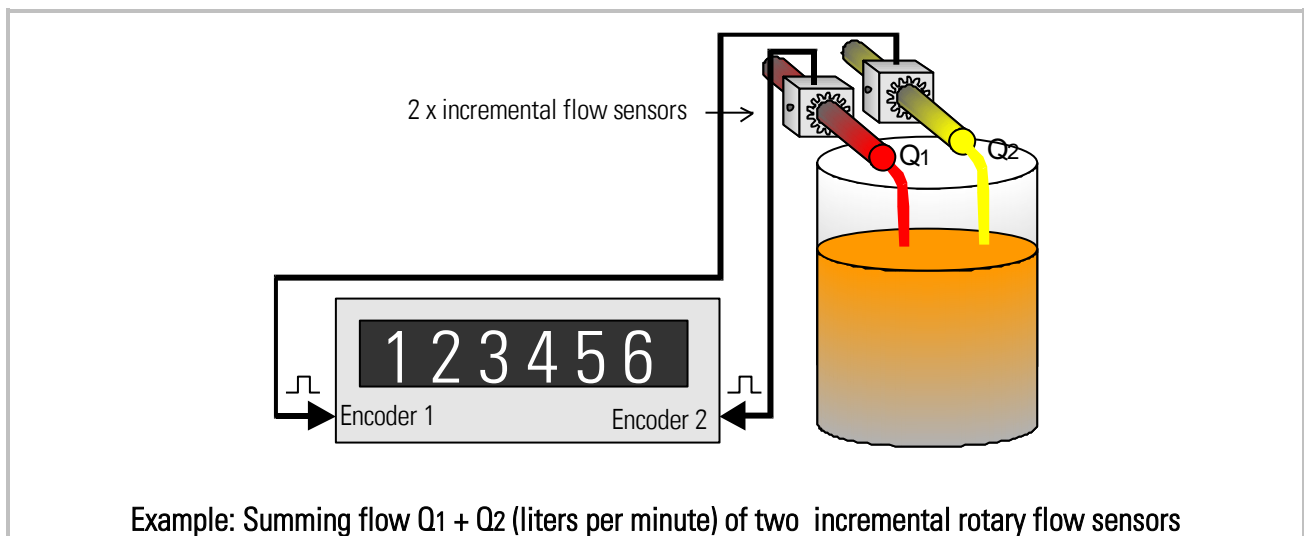

## 5.4. Differential Mode (encoder 1 - encoder 2): F02.004 = 3

Both inputs, encoder 1 and encoder 2, are active. From both values the unit forms the difference, with consideration of the individual scaling of each channel. The final result can once more be scaled into user-friendly engineering units by means of the special scaling parameters in parameter group F02.

Besides the actual speeds and the differential value, the unit also records minimum and maximum values of the speed difference.

Preset K1 is related to the absolute speed of encoder 1.

Preset K2 is related to the absolute speed of encoder 2.

Presets K3 and K4 are related to the actual differential speed (encoder 1 - encoder 2)

Display	L1 (red)	L2 (yellow)
1 Speed difference [speed encoder1] - [speed encoder2]	statically ON	statically ON
2 Minimum difference since last min/max reset	blinking slow	blinking slow
3 Maximum difference since last min/max reset	blinking fast	blinking fast
4 Actual measuring value of encoder 1	statically ON	---
5 Actual measuring value of encoder 2	---	statically ON

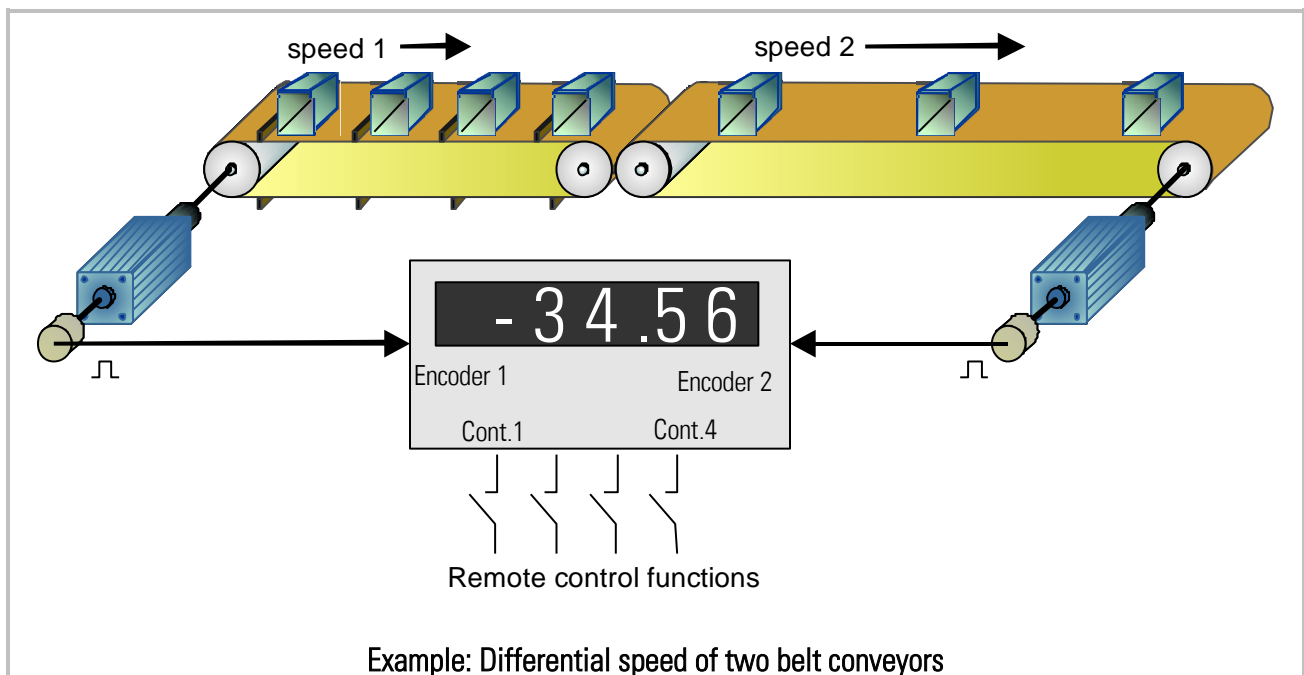

## 5.5. Product of Two Speeds (encoder 1 x encoder 2): F02.004 = 4

Both inputs, encoder 1 and encoder 2, are active. Both speeds are multiplied to form the product, with consideration of the individual scaling of each channel. The final result can once more be scaled into user-friendly engineering units by means of the special scaling parameters in parameter group F02.

Besides the actual speeds and the multiplication result, the unit also records minimum and maximum values of the product.

Preset K1 is related to the absolute speed of encoder 1.

Preset K2 is related to the absolute speed of encoder 2.

Presets K3 and K4 are related to the product of both speeds (encoder 1 x encoder 2)

	Display	L1 (red)	L2 (yellow)
1	Speed product [speed encoder1] x [speed encoder2]	statically ON	statically ON
2	Minimum product since last min/max reset	blinking slow	blinking slow
3	Maximum product since last min/max reset	blinking fast	blinking fast
4	Actual measuring value of encoder 1	statically ON	---
5	Actual measuring value of encoder 2	---	statically ON

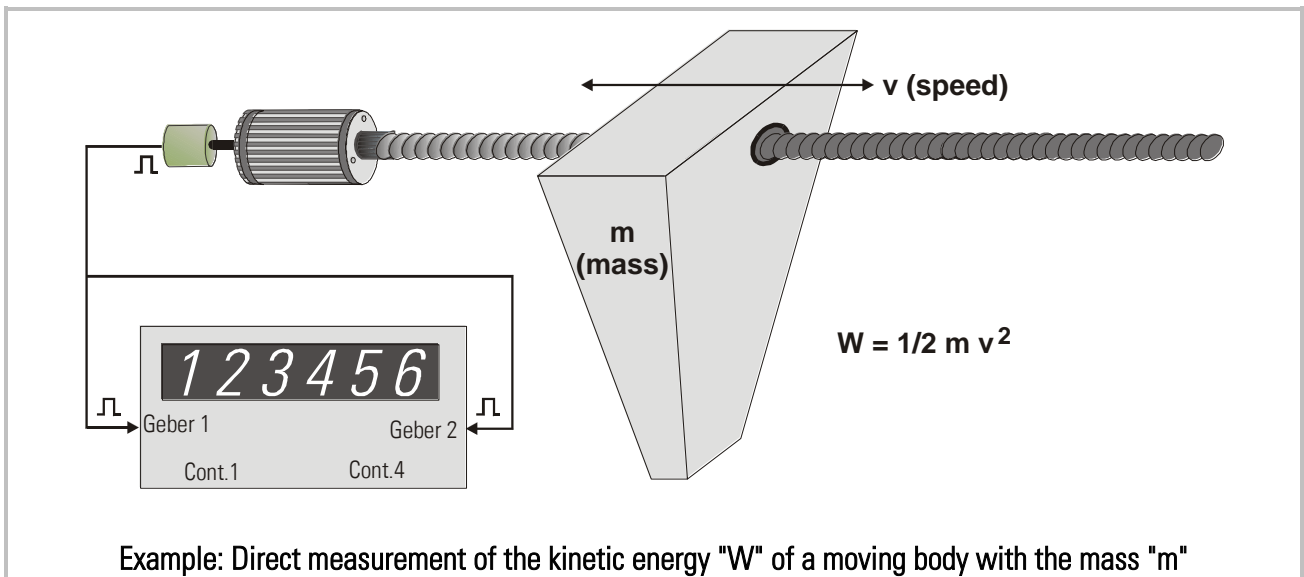

## 5.6. Ratio of two Speeds: F02.004 = 5 or 6

Both inputs, encoder 1 and encoder 2, are active. The unit calculates the ratio of the two speeds, with consideration of the individual scaling of each channel. The final result can once more be scaled into user-friendly engineering units by means of the special scaling parameters in parameter group F02 (conversion factor  $K = F02.09 : F02.08$ ), see figure below\*).

**F02.004 = 5** calculates [encoder1] : [encoder2]

**F02.004 = 6** calculates [encoder2] : [encoder1]

Besides the actual speeds and the ratio the unit also records minimum and maximum values of the ratio.

Preset K1 is related to the absolute speed of encoder 1.

Preset K2 is related to the absolute speed of encoder 2.

Presets K3 and K4 are related to the ratio of both speeds

Display		L1 (red)	L2 (yellow)
1	Speed ratio [encoder (1 or 2)] : [encoder (2 or 1)] *)	statically ON	statically ON
2	Minimum ratio since last min/max reset	blinking slow	blinking slow
3	Maximum ratio since last min/max reset	blinking fast	blinking fast
4	Actual speed of encoder 1	statically ON	---
5	Actual speed of encoder 2	---	statically ON

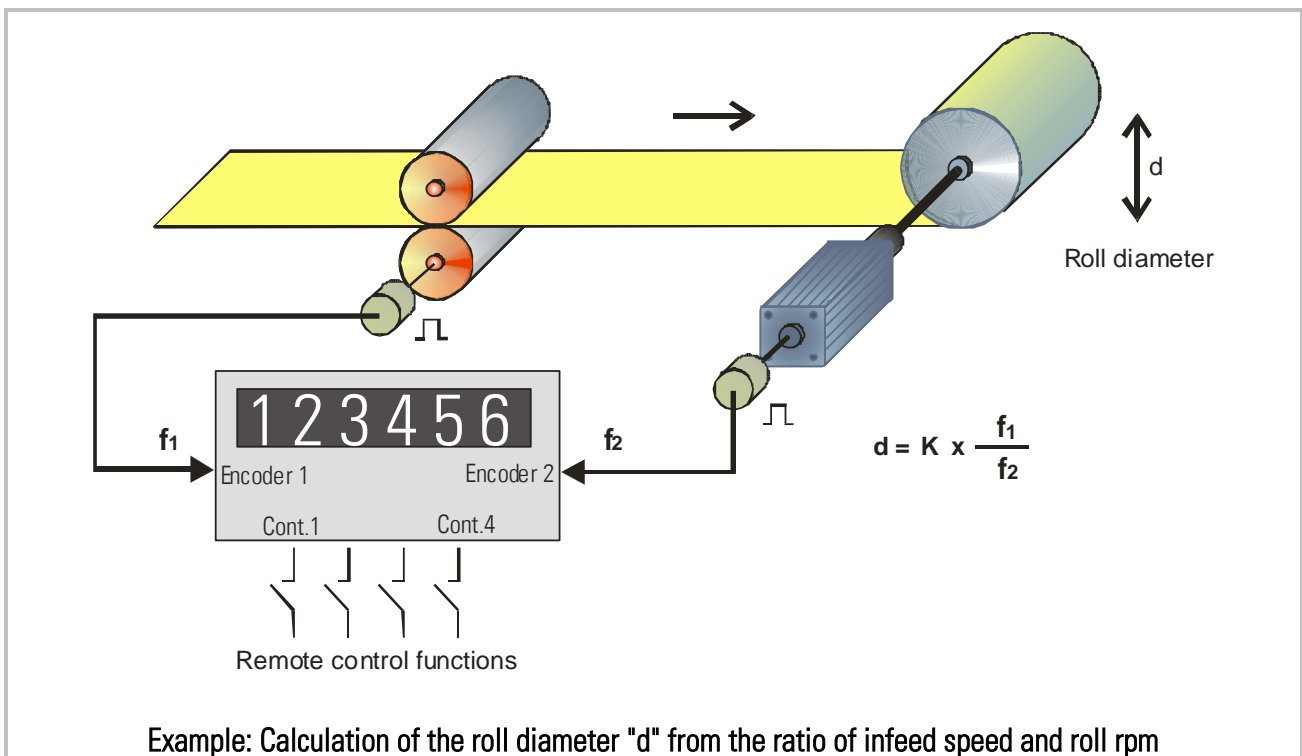

\*) The unit presents the ratio of the two speeds as an integer number only, e.g. if both speeds are equal, the unit would just display "1". To display a ratio with decimal positions like 1.0 or 1.00 or 1.000 etc. it is necessary to follow one of these hints:

- scale the speed used as numerator by a factor of 10 or 100 or 1000 higher than the denominator, or
- set parameters F02.009 (multiplier) and F02.008 (divider) with a ratio of 10, 100 or 1000

## 5.7. Percentage Speed Difference: F02.004 = 7 or 8

Both encoder inputs "encoder1" and "encoder2" are active. With consideration of the individual scaling of each channel the unit calculates the percentage difference as shown below:

F02.004 = 7:	Display = $\frac{[\text{speed of encoder 1}] - [\text{speed of encoder 2}]}{[\text{speed of encoder 2}]} \times 100\%$
F02.004 = 8:	Display = $\frac{[\text{speed of encoder 2}] - [\text{speed of encoder 1}]}{[\text{speed of encoder 1}]} \times 100\%$

<b>Parameter „Percent Format“ (F02.018) determines the number of decimal positions of the result:</b>	
0 = display range -999999 to + 9999999 %	1 = display range -99999,9 to +99999,9 %
2 = display range -9999,99 to +9999,99 %	3 = display range -999,999 to +999,999 %

The final percentage result can once more be scaled into user-friendly engineering units by means of the special scaling parameters in parameter group F02

Besides the actual speeds and the ratio the unit also records minimum and maximum values of the ratio.

Preset K1 is related to the absolute speed of encoder 1.

Preset K2 is related to the absolute speed of encoder 2.

Presets K3 and K4 are related to the percentage difference of both speeds

Display	L1 (red)	L2 (yellow)
1 Actual percentage difference	statically ON	statically ON
2 Minimum percentage since last min/max reset	blinking slow	blinking slow
3 Maximum percentage since last min/max reset	blinking fast	blinking fast
4 Actual speed of encoder 1	statically ON	---
5 Actual speed of encoder 2	---	statically ON

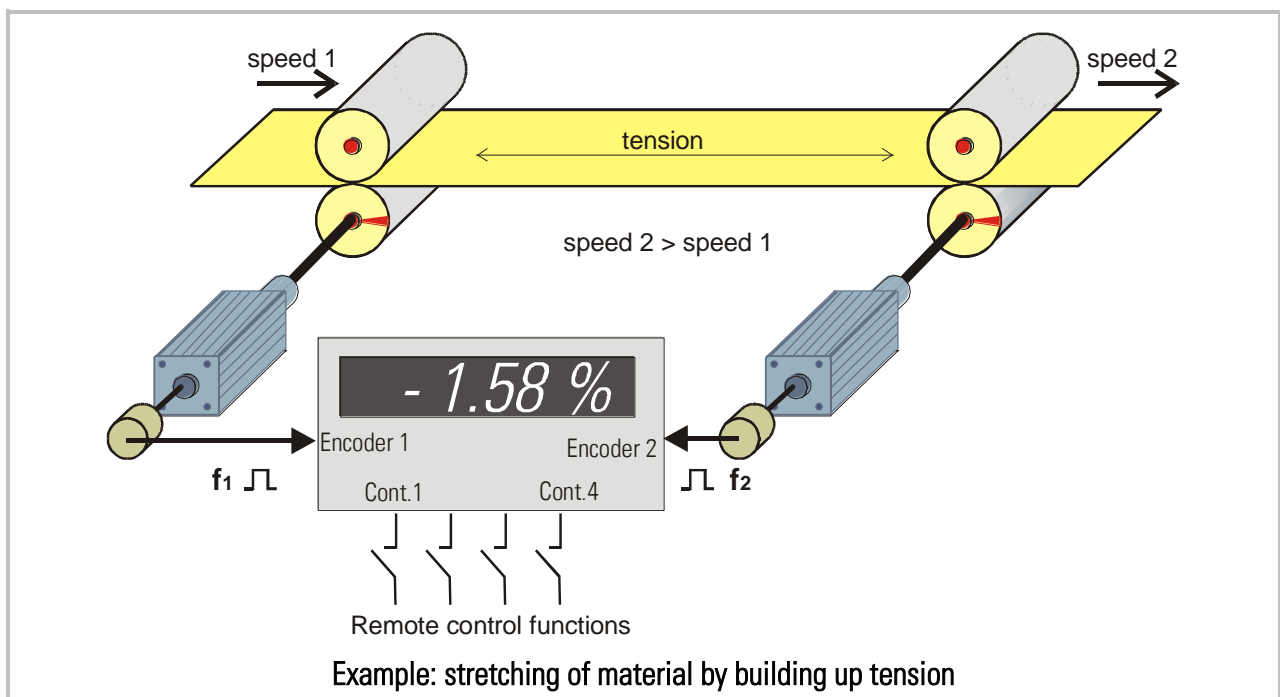

## 6. Keypad Operation

An overview of all parameters and explanations can be found under section [7](#).

The menu of the unit uses four keys, hereinafter named as follows:

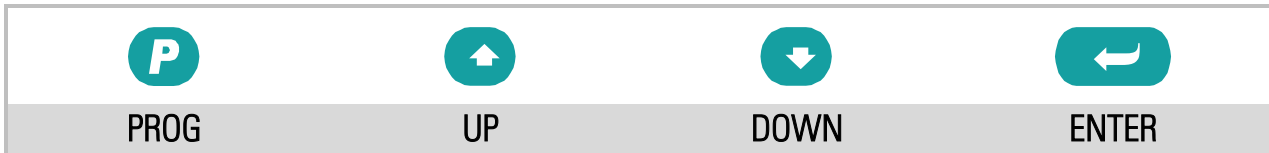

Key functions depend on the actual operating state of the unit. Essentially we have to describe three basic states:

- Normal operation
- General setup procedure
- Direct fast access to presets and set values

### 6.1. Normal Operation









In this mode the unit operates as a counter according to the settings defined upon setup. All front keys may have customer-defined functions according to the specifications met in the keypad definition menu F05 (e.g. scrolling of the display, Reset, Inhibit etc.)

### 6.2. General Setup Procedure

The unit changes over from normal operation to setup level when keeping the  key down for at least 2 seconds. Thereafter you can select one of the parameter groups F01 to F13.

Inside the group you can now select the desired parameter and set the value according to need. After this you can either set more parameters or return to the normal operation.

The adjoining sequence of key operations explains how to change **Parameter number 060 of group F06 from the original value of 0 to 8**

Step	State	Key action	Display	Comment
00	Normal operation		Actual value	
01		 > 2 sec.	F01	Display of the Parameter group
02	Level: Parameter group	 5 x	F02 ... F06	Select group # F06
03			F06.058	Confirmation of F06. The first parameter of this group is F06.058
04	Level: Parameter numbers	 2 x	F06.059... F06.060	Select parameter 060
05			0	Parameter 060 appears in display, actual setting is 0
06	Level: Parameter values	 8 x	1 .... 8	Setting has been modified from 0 to 8
07			F06.060	Save the new setting (8)
08	Level: Parameter numbers		F06	Return to level parameter groups
09	Level: Parameter groups		Actual value	Return to normal operation
10	Normal operation			



During the general setup procedure all counter activities remain disabled. New parameter settings become active after return to normal operation only.

### 6.3. Direct Fast Access to Presets

To get to the fast access routine, please press for at least 2 seconds both



and



at the same time





This will access the parameter group F01 right away. To change of the settings follow the same procedure as already described above. Besides the advantage of direct access, the fundamental difference to general setup is the following:



During the fast access procedure all counter functions remain fully active. Access is limited to presets; no other parameters can be changed.











## 6.4. Change of Parameter Values on the Numeric Level

The numeric range of the parameters is up to 6 digits. Some of the parameters may also include a sign. For fast and easy setting of these values the menu uses an algorithm as shown subsequently. During this operation the front keys have the following functions:

 <b>PROG</b>	 <b>UP</b>	 <b>DOWN</b>	 <b>ENTER</b>
Saves the actual value shown in the display and returns to the parameter selection level	Increments the highlighted (blinking) digit	Decrements the highlighted (blinking) digit	Shifts the cursor (blinking digit) one position to the left, or from utmost left to right

With signed parameters the left digit scrolls from **0 to 9** and then shows “-”, (negative) and “-1” (minus one). The example below shows how to change a parameter from the setting 1024 to the new setting 250 000.

This example assumes that you have already selected the parameter group and the parameter number, and that you actually read the parameter value in the display. Highlighted digits appear on colored background.

Step	Display	Key action	Comment
00	001024		Display of actual parameter setting, last digit is highlighted
01		 4 x	Scroll last digit down to 0
02	001020		Shift cursor to left
03	001020	 2 x	Scroll highlighted digit down to 0
04	001000	 2 x	Shift cursor 2 positions left
05	001000		Scroll highlighted digit down to 0
06	000000		Shift cursor left
07	000000	 5 x	Scroll highlighted digit up to 5
08	050000		Shift cursor left
09	050000	 2 x	Scroll highlighted digit up to 2
10	250000		Save new setting and return to the parameter number level



## 6.5. Code Protection against Unauthorized Keypad Access

Parameter group F07 allows to define an own locking code for each of the parameter menus. This permits to limit access to certain parameter groups to specific persons only.

When accessing a protected parameter group, the display will first show "CODE" and wait for your entry. To continue keypad operations you must now enter the code which you have stored before, otherwise the unit will return to normal operation again.

After entering your code, press the ENTER key and keep it down until the unit responds. When your code was correct, the response will be "YES" and the menu will work normally. With incorrect code the response will be "NO" and the menu remains locked.



In order to avoid inadvertent misadjustment upon commissioning, parameter groups F07 (keypad protection), F08 (special functions) and F11 (Linearization) are already protected by factory setting. For access please use code 6078

## 6.6. Return from the Programming Levels and Time-Out Function



At any time the PROG key sets the menu one level up and finally returns to normal operation. The same step occurs automatically via the time-out function, when during a period of 10 seconds no key has been touched.

Termination of the menu by automatic time-out will not store new settings, unless they have already been stored by the PROG key after editing.

## 6.7. Reset all Parameters to Factory Default Values

Upon special need it may be desirable to set all parameters back to their original factory settings (e.g. because you have forgotten your access code, or by too many change of settings you have achieved a complex parameter state). Default values are indicated in the parameter tables shown later.

To reset the unit to default, please take the following steps:

- Switch power off
- Press  and  simultaneously
- Switch power on while you keep down both keys



Where you decide to take this action, please note that all parameters and settings will be lost, and that you will need to run a new setup procedure again.

# 7. Menu Structure and Description of Parameters

All parameters are arranged in a reasonable order of functional groups (F01 to F13). Essential settings appear right at the beginning and optional parameters are located towards the end of the parameter list. You must only set those parameters which are really relevant for your specific application. Unused parameters can remain like set by default.

## 7.1. Summary of the Menu

This section shows a summary of the parameter groups, with an assignment to the functional parts of the unit.

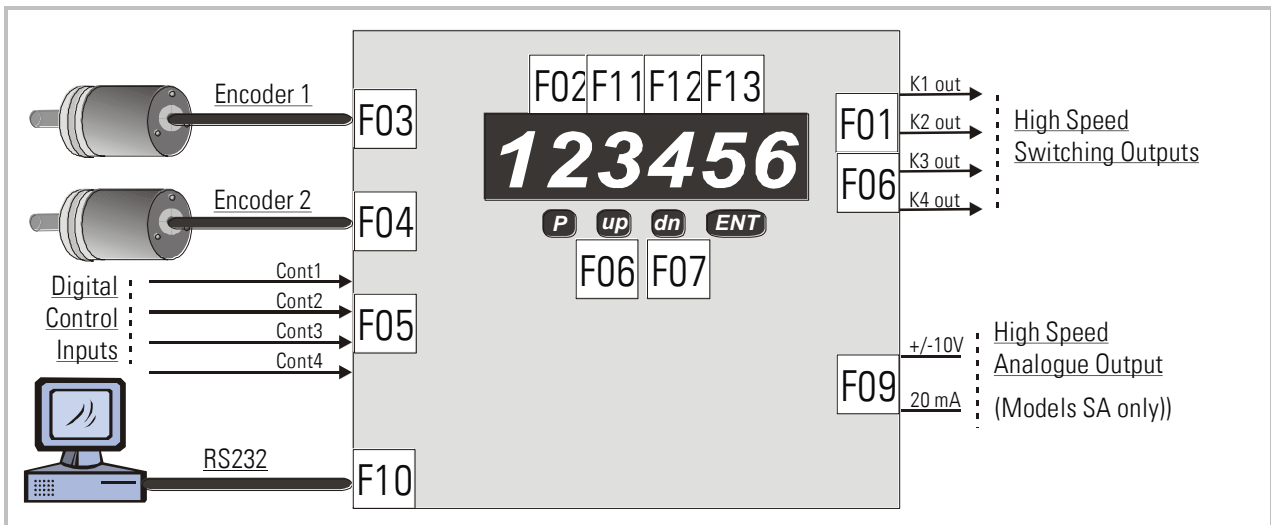

<b>F01 Preselections</b>	
000	Preselection switchpoint K1
001	Preselection switchpoint K2
002	Preselection switchpoint K3
003	Preselection switchpoint K4

<b>F02 Basic Settings</b>	
004	Mode of operation
005	Decimal point [encoder 1]
006	Decimal point [encoder 2]
007	Decimal point [encoder 1]* [encoder 2]
008	Divider (scaling factor)
009	Multiplier (scaling factor)
010	Display mode
011	Offset
012	Brightness of display
013	Update cycle time of display
014	Number of sampling impulses
015	Wait time for sampling
016	Synchronization encoder 1 / encoder 2
017	Limitation of input frequency range
018	Percentage display format

<b>F03 Encoder 1 Properties</b>	
022	Encoder 1 properties
023	Counting direction up / down
024	Sampling Time 1
025	Wait Time 1
026	Filter 1
027	Input frequency 1
028	Display value 1
029	Display mode 1
030	Set value 1
031	Start-up delay 1
032	Standstill definition 1

<b>F04 Encoder 2 Properties</b>	
034	Encoder 2 properties
035	Counting direction up / down
036	Sampling Time 2
037	Wait Time 2
038	Filter 2
039	Input frequency 2
040	Display value 2
041	Display mode 2
042	Set value 2
043	Start-up delay 2
044	Standstill definition 2

<b>F05 Key Commands and Control Inputs</b>	
046	Key UP
047	Key DOWN
048	Key ENTER
049	Control input 1, (characteristics)
050	Control input 1 (function)
051	Control input 2, (characteristics)
052	Control input 2 (function)
053	Control input 3, (characteristics)
054	Control input 3 (function)
055	Control input 4 (characteristics)
056	Control input 4 (function)

<b>F06 Switching Characteristics of Outputs</b>	
058	K1 (static or timed switching)
059	K2 (static or timed switching)
060	K3 (static or timed switching)
061	K4 (static or timed switching)
062	Hysteresis K1
063	Hysteresis K2
064	Hysteresis K3
065	Hysteresis K4
066	Preselection mode K1
067	Preselection mode K2
068	Preselection mode K3
069	Preselection mode K4
070	Output polarity (NO or NC)
071	Sign of Thumbwheel (SD6... only)
072	Thumbwheel assignment
073	Output locking upon power-up
074	Start-up delay
075	Self-retaining of outputs

<b>F07 Keypad Protection Codes</b>	
078	Code for F01
079	Code for F02
<--->	<--->
089	Code for F13

<b>F11 Range of Linearization</b>	
116	Linearization range encoder 1
117	Linearization range encoder 2

<b>F08 Special Functions</b>	
095	Encoder 1 trigger threshold
096	Encoder 2 trigger threshold

<b>F12 Linearization Table for Encoder 1</b>	
118	First interpolation point (x1, original value)
119	First interpolation point (y1, replacement)
<--->	<--->
148	Last interpolation point (x16, original value)
149	Last interpolation point (y16, replacement)

<b>F09 Analogue Output Definitions (SA only)</b>	
100	Output mode voltage / current
101	Conversion range, start value
102	Conversion range, end value
103	Analogue span
104	Analogue offset
105	Assignment of the analogue output

<b>F13 Linearization Table for Encoder 2</b>	
150	First interpolation point (x1, original value)
151	First interpolation point (y1, replacement)
<--->	<--->
180	Last interpolation point (x16, original value)
181	Last interpolation point (y16, replacement)

<b>F10 Serial Communication</b>	
106	Serial unit address
107	Baud rate
108	Data format
109	Communication protocol
110	Timer for auto-transmit
111	Serial register code for transmission
112	Command "Set"
113	Command "Freeze"
114	Command "Hold"

## 7.2. Description of the Parameters

### 7.2.1. Preselections and presets

F01		Range	Default
F01.000	Preselection K1	-199 999 ... 999 999	1 000
F01.001	Preselection K2	-199 999 ... 999 999	2 000
F01.002	Preselection K3	-199 999 ... 999 999	3 000
F01.003	Preselection K4	-199 999 ... 999 999	4 000

F02		Range	Default
F02.004	<b>Operational Mode:</b> 0= Single mode, evaluation of encoder 1 only 1= Dual mode, individual evaluation of encoder 1 and encoder 2 2= Sum mode, [encoder1] + [encoder2] 3= Differential mode, [encoder1] - [encoder2] 4= Multiplication mode, [encoder1] x [encoder2] 5= Ratio mode, [encoder1] : [encoder2] 6= Inverse ratio mode, [encoder2] : [encoder1] 7= Percentage mode, [encoder1 - encoder2] : [encoder2] x 100% 8= Percentage mode, [encoder2 - encoder1] : [encoder1] x 100%	0 ... 8	1
F02.005	<b>Decimal Point 1:</b> position of the decimal point with encoder 1	0 ... 5	0
F02.006	<b>Decimal Point 2:</b> position of the decimal point with encoder 2	0 ... 5	0
F02.007	<b>Decimal Point 12:</b> position of the decimal point with combinations [encoder 1]* [encoder 2]	0 ... 5	0
F02.008	<b>Divider:</b> reciprocal scaling factor for combined results	1 – 999 999	1000
F02.009	<b>Multiplier:</b> proportional scaling factor for combined results	1 – 999 999	1000
F02.010	<b>Total Display Mode (re-scaling of combined encoder results):</b> 0= Proportional presentation of the combination value, no further conversion $\text{Combined display value} = [\text{encoder1}] * [\text{encoder2}] \times \frac{\text{F02.009}}{\text{F02.008}}$ 1= Reciprocal presentation of the combination value, decimal format $\text{Combined display value} = \frac{\text{F02.008} \times \text{F02.009}}{[\text{encoder1}] * [\text{encoder2}]}$ 2= See above, but reciprocal presentation of the combination value with clock format 9999 min : 59 sec 3= See above, but reciprocal presentation of the combination value with clock format 99 h : 59 min : 59 sec	0 ... 3	0
F02.011	<b>Offset:</b> This constant value will be finally added to the scaling result (including sign)	-199 999 ... +999 999	0
F02.012	<b>Brightness of the 7-segment LED display</b> 0= 100% of max. brightness 1= 80% of max. brightness 2= 60% of max. brightness 3= 40% of max. brightness 4= ..20% of max. brightness	0 ... 4	0

F02		Range	Default
F02.013	<b>Display Update Time:</b> 0 = immediate display update after each result (fastest) 100 = timed update, approx. 1/sec (slowest)	0 - 100	0
F02.014	<b>Sampling Pulses: *a)</b> Number of input impulses on channel A to calculate a measuring result With all settings >0 the function of the parameters "Sampling Time" (F03.024 and F04.036) is disabled	0 – 30 000	0.50
F02.015	<b>Wait Time Sampling:</b> Time limit: if with use of parameter F02.014 the input pulses should get interrupted, a result will be calculated and displayed latest after elapse of this time limit	0.01 - 99.99 sec	0
F02.016	<b>Synchronization: *b)</b> Synchronization of encoder1 / encoder2 measurement  0 = Synchronization OFF. Evaluation of encoder1/encoder2 happens fully independently and at different times 1 = Synchronization ON. Evaluation of encoder1/encoder2 is synchronized and happens at the same time	0, 1	0
F02.017	<b>Input Limitation: *c)</b> Limitation of the input frequency (digital low-pass filter)  0 = no limitation of the input frequency 1 = Limitation to 500 kHz max.(both encoder inputs) 2 = Limitation to 100 kHz max.(both encoder inputs) 3 = Limitation to 10 kHz max.(both encoder inputs)	0 - 3	0
F02.018	<b>Percent Format:</b> Decimal presentation of percentage display  0 = Format +/-999999 %      1 = Format +/-99999,9 % 2 = Format +/-9999,99 %      3 = Format +/-999,999%	0 - 3	0



**\*) Important Hints:**

- a. With irregular and out-of-round motion-sequence it may be advantageous to use a fixed number of input pulses for sampling, instead of a sampling time. This method is suitable to stabilize or suppress undulation of the display (e.g. with unbalanced and eccentric movements) because an overall average of one undulation is formed
- b. It is advisable to always use the synchronized mode whenever measuring speed ratios or percentage speed difference. Otherwise unacceptable variation of the display may occur, caused by the different timing of the two speed values  
  
With the synchronization set to ON, parameters "Sampling Time1" (or "Sampling Pulses") as well as "Wait Time1" are used conjointly for both encoders and the corresponding settings for encoder 2 are inoperative. The response time of the unit depends in each case on the lower one of the two input frequencies
- c. Where the low-pass filter is used to limit the input frequency, higher frequencies than indicated will no more be evaluated correctly.

## 7.2.2. Definitions for encoder 1

F03		Range	Default
F03.022	<b>Encoder Properties1:</b> 0= Differential impulses A, /A, B, /B (2 x 90° *) 1= Single-ended HTL impulses (10 - 30 V, format A, B, 2 x 90°) 2= Differential impulse input A, /A (count, step) *) Differential signal B, /B (static direction signal) 3= Single-ended HTL impulse A (count, step) Single-ended HTL signal B (static direction signal) 4= Differential impulse input A, /A only *) 5 Single-ended HTL impulse input A only	0 ... 5	1
F03.023	<b>Direction1:</b> positive or negative speed (forward / reverse) 0= Positive speed when A leads B 1= Positive speed when A lags B	0 ... 1	0
F03.024	<b>Sampling Time1:</b> Internal measuring time to evaluate the frequency	0.000**) ... 9.999 sec.	0.001
F03.025	<b>Wait Time1:</b> Maximum time to wait for the next input pulse When after this waiting time no further impulse appears, the frequency result is set to zero (f = 0)	0.01 ... 99.99 sec.	1.00
F03.026	<b>Filter1:</b> Digital filter for smoothing unstable input frequencies (for detailed explications see <a href="#">8.4</a> ) 0= Filter OFF (very fast response to changes in frequency) 1= Floating average over the last 2 measuring cycles 2= Floating average over the last 4 measuring cycles 3= Floating average over the last 8 measuring cycles 4= Floating average over the last 16 measuring cycles 5= Exponential filter, T (63%) = 2 x Sampling Time 6= Exponential filter, T (63%) = 4 x Sampling Time 7= Exponential filter, T (63%) = 8 x Sampling Time 8= Exponential filter, T (63%) = 16 x Sampling Time (very slow response to changes in frequency)	0 - 8	0
F03.027	<b>Input Value1:</b> Typical input frequency of the application (Hz) for use as a scaling reference for the display	1 - 999 999 Hz	1000
F03.028	<b>Display Value1:</b> Desired display value This numeric value appears in the display when the reference frequency is applied to the input (as set under "Input Value")	1 - 999 999	1000

\*) this is valid for any kind of differential input signal (i.e. signal + inverted signal), no matter if RS422 or TTL or HTL level

\*\*) minimum sampling time at 0.000 (<1ms)

F03		Range	Default
F03.029	<p><b>Display Mode1:</b> Measuring characteristics of the display *)</p> <p><b>0= Proportional characteristics</b>            Suitable for measurement of rpm, speed and frequency            The display value is proportional to the input frequency "f".</p> $\text{Display} = \frac{f \text{ (Hz)} \times \text{F03.028}}{\text{F03.027}}$ <p><b>1= Reciprocal characteristics, decimal format 999999</b>            Suitable for measurement of baking times, through-put time and other processing times            The display value is inversely proportional to the input frequency "f"</p> $\text{Display} = \frac{\text{F03.028} \times \text{F03.027}}{f \text{ (Hz)}}$ <p><b>2= Reciprocal, clock format 9999 min : 59 sec **)</b>            otherwise all similar to setting 1</p> <p><b>3= Reciprocal, clock format 99 h : 59 min : 59 sec **)</b>            otherwise all similar to setting 1</p>	0 - 3	0
F03.030	<p><b>Set Value1:</b> Preset value to simulate fixed input frequency</p> <p>When you have assigned the function "Set Frequency 1" to any of the front keys or the control inputs (see parameter group F05), then this function can be used to temporary substitute the real input frequency of encoder 1 by a virtual frequency according to setting. This e.g. allows simulation of the unit and all functions / outputs while the machine itself is in standstill. When the Set Value1 is set to 2000 the frequency value corresponds to 20.00 Hz.</p>	-199 999 ... 999 999 (x.xx Hz)	0



- \*) Practical setting examples for these display modes can be found in chapter [8](#).
- \*\*) For setup and scaling of the unit please always use decimal format first and set your display to full seconds. When you find that all other functions work fine, then change over to the desired clock format.



F03		Range	Default
F03.031	<p><b>Start-up Mode1:</b> Start-up delay for the switching outputs *)</p> <p>The start-up delay is suitable to temporarily suppress the control function of a switching output (in general for monitoring of a minimum value). The machine then is allowed to start up first, prior to activation of the alarm. The start-up delay becomes active upon power-up of the unit or after the unit has detected "standstill".</p> <p>The start-up delay depends on the selected operational mode:</p> <ul style="list-style-type: none"> <li>- in <b>Operational Mode 0</b> the <b>Start-up Mode 1</b> refers to <b>K1</b> up to <b>K4</b></li> <li>- in <b>Operational Mode 1</b> the <b>Start-up Mode 1</b> refers to <b>K1</b> and <b>K2</b></li> <li>- in <b>Operational Mode 2 - 8</b> the <b>Start-up Mode 1</b> refers only to <b>K1</b></li> </ul> <p>The following settings are available (always for encoder 1):</p> <ul style="list-style-type: none"> <li>0 = Start-up delay OFF</li> <li>1 = timed delay: 001 second</li> <li>2 = timed delay: 002 seconds</li> <li>3 = timed delay: 004 seconds</li> <li>4 = timed delay: 008 seconds</li> <li>5 = timed delay: 016 seconds</li> <li>6 = timed delay: 032 seconds</li> <li>7 = timed delay: 064 seconds</li> <li>8 = timed delay: 128 seconds</li> <li>9 = automatic delay until first exceeding of the minimum value</li> <li>10 = external suppression by means of a control input</li> </ul>	0 ... 10	0
F03.032	<p><b>Standstill Time1:</b> Time for definition of "standstill" of encoder 1</p> <p>After the unit has detected "frequency = 0" (see parameter "Wait Time1"), the unit will continue waiting until "Standstill Time1" has elapsed and then finally report "standstill of encoder 1".</p>	0.00 ... 99,99 sec.	0.00

\*) When you use the start-up delay function with combined modes [encoder1] \* [encoder2], always the longest of both settings will be responsible for start-up

### 7.2.3. Definitions for encoder 2 (not relevant if only one encoder is used)

F04		Range	Default
F04.034	<b>Encoder Properties2:</b> 0= Differential impulses A, /A, B, /B (2 x 90° *) 1= Single-ended HTL impulses (10 - 30 V, format A, B, 2 x 90°) 2= Differential impulse input A, /A (count, step) *) Differential signal B, /B (static direction signal) 3= Single-ended HTL impulse A (count, step) Single-ended HTL signal B (static direction signal) 4= Differential impulse input A, /A only *) 5= Single-ended HTL impulse input A only	0 ... 5	1
F04.035	<b>Direction2:</b> positive or negative speed (forward / reverse) 0= Positive speed when A leads B 1= Positive speed when A lags B	0 ... 1	0
F04.036	<b>Sampling Time2:</b> Internal measuring time to evaluate the frequency	0.000**) ... 9.999 sec.	0.001
F04.037	<b>Wait Time2:</b> Maximum time to wait for the next input pulse When after this waiting time no further impulse appears, the frequency result is set to zero (f = 0)	0.01 ... 99.99 sec.	1.00
F04.038	<b>Filter2:</b> Digital filter for smoothing unstable input frequencies (for detailed explanations see <a href="#">8.4</a> ) 0= Filter OFF (very fast response to changes in frequency) 1= Floating average over the last 2 measuring cycles 2= Floating average over the last 4 measuring cycles 3= Floating average over the last 8 measuring cycles 4= Floating average over the last 16 measuring cycles 5= Exponential filter, T (63%) = 2 x Sampling Time 6= Exponential filter, T (63%) = 4 x Sampling Time 7= Exponential filter, T (63%) = 8 x Sampling Time 8= Exponential filter, T (63%) = 16 x Sampling Time (very slow response to changes in frequency)	0 - 8	0
F04.039	<b>Input Value2:</b> Typical input frequency of the application (Hz) for use as a scaling reference for the display	1 - 999 999 Hz	1000
F04.040	<b>Display Value2:</b> Desired display value This numeric value appears in the display when the reference frequency is applied to the input (as set under "Input Value")	1 - 999 999	1000

\*) this is valid for any kind of differential input signal (i.e. signal + inverted signal), no matter if RS422 or TTL or HTL level

\*\*) minimum sampling time at 0.000 (<1ms)

F04		Range	Default
F04.041	<b>Display Mode2: Measuring characteristics of the display *)</b> <b>0= Proportional characteristics</b> Suitable for measurement of rpm, speed and frequency The display value is proportional to the input frequency "f". $\text{Display} = \frac{f \text{ (Hz)} \times \text{F04.040}}{\text{F04.039}}$ <hr/> <b>1= Reciprocal characteristics, decimal format 999999</b> Suitable for measurement of baking times, through-put time and other processing times The display value is inversely proportional to the input frequency "f" $\text{Display} = \frac{\text{F04.040} \times \text{F04.039}}{f \text{ (Hz)}}$ <hr/> <b>2= Reciprocal, clock format 9999 min : 59 sec **)</b> otherwise all similar to setting 1 <hr/> <b>3= Reciprocal, clock format 99 h : 59 min : 59 sec **)</b> otherwise all similar to setting 1	0 - 3	0
F04.042	<b>Set Value2: Preset value to simulate fixed input frequency</b> When you have assigned the function "Set Frequency 2" to any of the front keys or the control inputs (see parameter group F05), then this function can be used to temporary substitute the real input frequency of encoder 2 by a virtual frequency according to setting. This e.g. allows simulation of the unit and all functions / outputs while the machine itself is in standstill. When the Set Value2 is set to 2000 the frequency value corresponds to 20.00 Hz.	-199 999 ... 999 999 (x.xx Hz)	0



\*) Practical setting examples for these display modes can be found in chapter [7](#).

\*\*) For setup and scaling of the unit please always use decimal format first and set your display to full seconds. When you find that all other functions work fine, then change over to the desired clock format.

F04		Range	Default
F04.043	<p><b>Start-up Mode2:</b> Start-up delay for the switching outputs *)</p> <p>The start-up delay is suitable to temporarily suppress the control function of a switching output (in general for monitoring of a minimum value). The machine then is allowed to start up first, prior to activation of the alarm. The start-up delay becomes active upon power-up of the unit or after the unit has detected "standstill".</p> <p>The start-up delay depends on the selected operational mode:</p> <ul style="list-style-type: none"> <li>- in <b>Operational Mode 0</b> the <b>Start-up Mode 2</b> has no function</li> <li>- in <b>Operational Mode 1</b> the <b>Start-up Mode 2</b> refers to <b>K3</b> and <b>K4</b></li> <li>- in <b>Operational Mode 2 - 8</b> the <b>Start-up Mode 2</b> refers only to <b>K2</b></li> </ul> <p>The following settings are available (always for encoder 2):</p> <ul style="list-style-type: none"> <li>0 = Start-up delay OFF</li> <li>1 = timed delay: 001 second</li> <li>2 = timed delay: 002 seconds</li> <li>3 = timed delay: 004 seconds</li> <li>4 = timed delay: 008 seconds</li> <li>5 = timed delay: 016 seconds</li> <li>6 = timed delay: 032 seconds</li> <li>7 = timed delay: 064 seconds</li> <li>8 = timed delay: 128 seconds</li> <li>9 = automatic delay until first exceeding of the minimum value</li> <li>10 = external suppression by means of a control input</li> </ul>	0 ... 10	0
F04.044	<p><b>Standstill Time2:</b> Time for definition of "standstill" of encoder 2</p> <p>After the unit has detected "frequency = 0" (see parameter "Wait Time2"), the unit will continue waiting until "Standstill Time2" has elapsed and then finally report "standstill of encoder 2".</p>	0.00 ... 99,99 sec.	0.00

\*) When you use the start-up delay function with combined modes [encoder1] \* [encoder2], always the longest of both settings will be responsible for start-up

## 7.2.4. Keypad Commands and Control Input Definitions

F05		Range	Default
F05.046	<b>Function assignment to key „UP“</b>	0 ... 17	0
	0= no function 1= Substitute encoder frequency 1 by Set Value F03.030 (s) 2= Substitute encoder frequency 2 by Set Value F04.042 (s) 3= Substitute both encoder frequencies (1 and 2) (s) 4= Freeze the actual frequency of encoder 1 *) (s) 5= Freeze the actual frequency of encoder 2 *) (s) 6= Freeze both encoder frequencies (1 and 2 *) (s) 7= Release maintain / latch state of output 1 / relay 1 (d) 8= Release maintain / latch state of output 2 / relay 2 (d) 9= Release maintain / latch state of output 3 / relay 3 (d) 10= Release maintain / latch state of output 4 / relay 4 (d) 11= Release maintain / latch state of all outputs / relays (d) 12= Remote start-up delay, see F03.031 / F04.043 (s) 13= Cycle display (d) 14= Reset all min/max records to the actual display value (d) 15= n. a. 16= Read thumbwheel switches **) (d) 17= Start serial transmission (d)		
F05.047	<b>Function assignment to key „DOWN“</b>	0 ... 17	0
	see key „UP“, F05.046		
F05.048	<b>Function assignment to key „ENTER“</b>	0 ... 17	0
	see key „UP“, F05.046		

\*) The latest actual measuring value is temporary frozen. This will affect the display and the switching outputs as well. The measuring procedure however will continue in the background.

\*\*) Reading of the actual settings of the thumbwheels with models 642/644 (see chapter [9.3](#))

(s) = static function (on/off) (d) = dynamic function, edge-triggered

F05	(continued)	Range	Default
F05.049	<b>Switching Characteristics of Input „Cont.1“</b> 0= NPN (switch to – ), function active LOW 1= NPN (switch to – ), function active HIGH 2= NPN (switch to – ), rising edge 3= NPN (switch to – ), falling edge 4= PNP (switch to + ), function active LOW 5= PNP (switch to + ), function active HIGH 6= PNP (switch to + ), rising edge 7= PNP (switch to + ), falling edge	0 ... 7	0
F05.050	<b>Function Assignment to Input „Cont.1“</b> 0= no function 1= Substitute encoder frequency 1 by Set Value F03.030 (s) 2= Substitute encoder frequency 2 by Set Value F04.042 (s) 3= Substitute both encoder frequencies (1 and 2) (s) 4= Freeze the actual frequency of encoder 1 (s) *) 5= Freeze the actual frequency of encoder 2 *) (s) *) 6= Freeze both encoder frequencies (1 and 2) *) (s) *) 7= Release maintain / latch state of output 1 / relay 1 (d) 8= Release maintain / latch state of output 2 / relay 2 (d) 9= Release maintain / latch state of output 3 / relay 3 (d) 10= Release maintain / latch state of output 4 / relay 4 (d) 11= Release maintain / latch state of all outputs / relays (d) 12= Remote start-up delay, see F03.031 / F04.043 (s) 13= Cycle display (d) 14= Reset all min/max records to the actual display value (d) 15= Hardware keypad lock (s) 16= Read thumbwheel switches (d) **) 17= Start serial transmission (d)	0 ... 17	0
F05.051	<b>Switching Characteristics of Input „Cont.2“</b> (see „Cont.1“ F05.049)	0 ... 7	0
F05.052	<b>Function Assignment to Input „Cont.2“</b> (see „Cont.1“ F05.050)	0 ... 17	0
F05.053	<b>Switching Characteristics of Input „Cont.3“</b> (see „Cont.1“ F05.049)	0 ... 7	0
F05.054	<b>Function Assignment to Input „Cont.3“</b> (see „Cont.1“ F05.050)	0 ... 17	0
F05.055	<b>Switching Characteristics of Input „Cont.4“</b> (see „Cont.1“ F05.049) This input will not support dynamic (edge-triggered) function!	0...3	0
F05.056	<b>Function Assignment to Input „Cont.4“</b> (see „Cont.1“ F05.050)	0 ... 17	0



**Open (unconnected) NPN inputs are always HIGH (internal pull-up resistor)**  
**Open (unconnected) PNP inputs are always LOW (internal pull-down resistor)**

\*) The latest actual measuring value is temporary frozen. This will affect the display and the switching outputs as well. The measuring procedure however will continue in the background.

\*\*) Reading of the actual settings of the thumbwheels with models 642/644 (see [9.3](#))

(s) = static function (on/off) (d) = dynamic function, edge-triggered

## 7.2.5. Switching Characteristics of Outputs and Preselection Properties

F06		Range	Default
F06.058	<b>Pulse Time 1</b> Output pulse time (sec.) for output K1 (0 = static operation)	0.00 ... 9.99	0.00
F06.059	<b>Pulse Time 2</b> Output pulse time (sec.) for output K2 (0 = static operation)	0.00 ... 9.99	0.00
F06.060	<b>Pulse Time 3</b> Output pulse time (sec.) for output K3 (0 = static operation)	0.00 ... 9.99	0.00
F06.061	<b>Pulse Time 4</b> Output pulse time (sec.) for output K4 (0 = static operation)	0.00 ... 9.99	0.00
F06.062	<b>Switching hysteresis of output K1</b> (display units) *)	0 ... 99999	0
F06.063	<b>Switching hysteresis of output K2</b> (display units) *)		
F06.064	<b>Switching hysteresis of output K3</b> (display units) *)		
F06.065	<b>Switching hysteresis of output K4</b> (display units) *)		
F06.066	<b>Preselection Mode 1</b> K1 switching mode 0= switches when [Actual Value] ≥ [Preset], no start-up delay. Maintain/latch is possible 1= switches when [Actual Value] ≤ [Preset], start-up delay included. Maintain/latch is possible 2= Window characteristics: switches when [Actual Value] > [Preset] +/- Hysteresis, start-up delay included. Maintain/latch is possible 3= Standstill detection Switches when after frequency = 0 also the Standstill Time has elapsed. No start-up delay, no maintain/latch function 4= Switches with Actual Value ≥ Preset. No start-up delay, maintain/latch is possible 5= Switches when Actual Value ≤ Preset No start-up delay, maintain/latch is possible 6= Window characteristics: switches when Actual Value > Preset +/- Hysteresis, no start-up delay, maintain/latch is possible 7= Direction of rotation "Forward" Switches with positive direction (edge A leads B). Switches OFF upon standstill (frequency = 0 and standstill time elapsed) 8= see 7, but "Reverse" (edge B leads A)	0 ... 8  <b>[Actual Value] means:</b> Absolute speed value. The unit will not consider the sign or the direction but switch both ways  <b>Actual Value means:</b> Signed speed value. The unit will consider the direction and switch only in one direction according to the actual sign	0
F06.067	<b>Preselection Mode 2</b> (see Preselection Mode 1, but K2)	0 ... 8	0
F06.068	<b>Preselection Mode 3</b> (see Preselection Mode 1, but K3)		
F06.069	<b>Preselection Mode 4</b> (see Preselection Mode 1, but K4)		

\*) Switching point = Preselection, switch-back point is displaced by the Hysteresis setting

F06		Range	Default
F06.070	<b>Output Polarity:</b> "Normally Open" or "Normally Closed" *) K1= binary value = 1 K2= binary value = 2 K3= binary value = 4 K4= binary value = 8 Bit = 0: OFF state = de-energized, ON state = energized (N.O.) Bit = 1: OFF state = energized, ON state = de-energized (N.C.)	0 ... 15  <u>Example:</u> Setting "9" (binary 1-0-0-1) means: K1 and K4 = N.C. *) K2 and K3 = N.O. *)	0
F06.071	<b>Thumbwheel Sign:</b> Sign of thumbwheel switch (models 6xx only)	0 - 15 see chapter <a href="#">9.3</a>	0
F06.072	<b>Thumbwheel Configuration:</b> Assignment of the thumbwheel switches (models 6xx only)	0 - 23 see chapter <a href="#">9.3</a>	0
F06.073	<b>Output Lock:</b> Disabling of timed output pulses during power-up **)	0: Output pulses enabled 1: Output pulses disabled	0
F06.074	<b>Start-up Configuration:</b> Assignment of start-up delays K1= binary value = 1 K2= binary value = 2 K3= binary value = 4 K4= binary value = 8 Bit = 0: no start-up delay Bit = 1: start-up delay active	0 ... 15  <u>Example:</u> Setting "12" (binary 1-1-0-0) means: K1 und K2 = no delay K3 und K4 = start-up delay active	0
F06.075	<b>Lock Configuration:</b> Assignment of maintain / latch functions K1= binary value = 1 K2= binary value = 2 K3= binary value = 4 K4= binary value = 8 Auto-Release= binary value = 16 Bit = 0: no maintain / latch Bit = 1: maintain / latch function active	0 ... 15 (without Auto-Release)  or  16 ... 31 (with Auto-Release)	0

Example:

With setting "02" (binary 0-0-0-1-0) output K2 will be latched,

The latch state can only be released remotely (either by front key or by control input or by serial command).

With setting "18" (binary 1-0-0-1-0) output K2 will be latched, too.

As above, the latch state can be released at any time by front key or by control input or by serial command.

However the outputs are also automatically released as soon as the unit detects "Standstill"



\*) N.O. means "normally open", saying that the corresponding output is normally switched OFF and will switch on when the assigned event happens.

\*) N.C. means "normally closed", saying that the corresponding output is normally switched ON and will switch off when the assigned event happens.

\*\*) Will block the timed output signals, until the first exceedance of a preselection value.  
Then the timed output signals will behave according to the defined preselection values.



## 7.2.6. Code Protection for Keypad Access

F07		Range	Default
F07.078	Access code for parameter group F01	0 = no protection  1 – 999 999 = individual access code for the corresponding parameter group	0
F07.079	Access code for parameter group F02		0
F07.080	Access code for parameter group F03		0
F07.081	Access code for parameter group F04		0
F07.082	Access code for parameter group F05		0
F07.083	Access code for parameter group F06		0
F07.084	Access code for parameter group F07		6078
F07.085	Access code for parameter group F08		6078
F07.086	Access code for parameter group F09		0
F07.087	Access code for parameter group F10		0
F07.088	Access code for parameter group F11		6078
F07.089	Access code for parameter group F12		0
F07.090	Access code for parameter group F13		0



In order to avoid inadvertent misadjustment upon commissioning, parameter groups F07 (keypad protection), F08 (special functions) and F11 (Linearization) are already protected by factory setting. For access please use code 6078

## 7.2.7. Special Functions

F08		Range	Default
F08.095	<b>Trigger Threshold 1:</b> Switching threshold for encoder 1 signals *)	30 ... 250	166
F08.096	<b>Trigger Threshold 2:</b> Switching threshold for encoder 2 signals *)	30 ... 250	166

\*) Must be set to the default value (166) at any time, except if exceptionally single-ended TTL signals should be used. Only in this case a setting of 35 is required.

## 7.2.8. Definitions for the Analogue Output (models SA only)

F09		Range	Default
F09.100	<b>Analogue Output Format:</b> 0= Voltage, bipolar -10 V ... +10 V 1= Voltage, unipolar 0 V ... +10 V 2= Current 4 ... 20 mA 3= Current 0 ... 20 mA	0 ... 3	0
F09.101	<b>Analogue Start:*)</b> Beginning of the conversion range (display) <b>Please note:</b> „Analogue Start“ represents the value, where the analogue output should start with 0 V. )* <i>... see example below</i>	-199 999 ... 999 999	0
F09.102	<b>Analogue End:</b> End of the conversion range (display)	-199 999 ... 999 999	10 000
F09.103	<b>Analogue Swing:</b> Full scale voltage or current (100 = 10 V or 20 mA)	0 ... 1000	100
F09.104	<b>Analogue Offset:</b> Zero point shift in mV	-10 000 ... 10 000	0
F09.105	<b>Analogue Assignment:</b> Assignment of the analogue output to one of the 6 lines which can be displayed by cycling	0 ... 5 (line 1) ... (line 6)	0

\*) **Example:** If a display range of -250 to +250 must output a proportional analogue range from -10 V to +10 V, the “Analogue Start” parameter must be set to **0** and the “Analogue End” value to **+250**.

## 7.2.9. Serial Communication Parameters

F10		Range	Default
F10.106	<b>Serial device address:</b> Unit Number You can assign any unit number between 11 and 99. Addresses containing zeros are not permitted, since reserved for collective addressing.	0 ... 99	11
F10.107	<b>Serial baud rate:</b> 0= 9600 Bauds 1= 4800 Bauds 2= 2400 Bauds 3= 1200 Bauds 4= 600 Bauds 5= 19200 Bauds 6= 38400 Bauds	0 ... 6	0
F10.108	<b>Serial data format:</b> 0= 7 Data, Parity even, 1 Stop 1= 7 Data, Parity even, 2 Stop 2= 7 Data, Parity odd, 1 Stop 3= 7 Data, Parity odd, 2 Stop 4= 7 Data, no Parity, 1 Stop 5= 7 Data, no Parity, 2 Stop 6= 8 Data, Parity even, 1 Stop 7= 8 Data, Parity odd, 1 Stop 8= 8 Data, no Parity, 1 Stop 9= 8 Data, no Parity, 2 Stop	0 ... 9	0
F10.109	<b>Serial Printer-Protocol: *)</b> 0= Output string = Unit Nr. – Data, LF, CR 1= Output string = Data, LF, CR	0 ... 1	1
F10.110	<b>Serial Timer:</b> for timed transmissions (sec.) *)	0.000 ... 99.999	0.000
F10.111	<b>Serial Parameter code: *)</b> Register code of the parameter to transmit	0 ... 26	14
F10.112	<b>Serial command "Set Frequency":</b> Assignment of the input channels to be substituted by the corresponding set frequency upon a serial "set" command 0 = Serial setting OFF 1 = Set encoder channel 1 to set frequency F03.030 2 = Set encoder channel 2 to set frequency F04.042 3 = Set both encoder channels to their set frequency	0 ... 3	0
F10.113	<b>Serial command "Freeze"</b> Assignment of the input channels to be frozen upon a serial "Freeze" command 0 = Serial Freeze command OFF 1 = Encoder 1 frequency enabled to freeze 2 = Encoder 2 frequency enabled to freeze 3 = Encoder 1 and encoder 2 frequency enabled to freeze	0 ... 3	0

\*) More details about serial operation are available in chapter [10](#).

F10	(continued)	Range	Default
F10.114	<b>Serial command "Self-hold Release"</b>	0 ... 15	0
	Assignment of the outputs to release from maintain/latch state upon a serial "Release" command	<u>Example:</u> Setting "6" (binary 0110) will release outputs K2 and K3	
	Output K1= binary value 1		
	Output K2= binary value 2		
	Output K3= binary value 4		
	Output K4= binary value 8		
	Bit = 0: Latch state of corresponding relay will not release		
	Bit = 1: Latch state of corresponding relay will release		

\*) More details about serial operation are available in chapter [10](#).

### 7.2.10. Parameters for Linearization

F11	Modes of Linearisation	Range	Default
F11.116	Mode of linearization for speed 1 (encoder 1) 0 = Linearisation off 1 = Linearisation is defined for the numeric range from 0 to +999 999 only and negative values will appear as a mirror of the positive values 2 = Linearisation is defined over the full range from -199 999 to +999 999	0 – 2  (see <a href="#">7.2.11</a> )	0
F11.117	Mode of linearization for speed 2 (encoder 2) 0 = Linearisation off 1 = Linearisation is defined for the numeric range from 0 to +999 999 only and negative values will appear as a mirror of the positive values 2 = Linearisation is defined over the full range from -199 999 to +999 999	0 – 2  (see <a href="#">7.2.11</a> )	0

F12	Table of linearization for speed 1 (encoder 1)	Range	Default
F12.118	First interpolation point, (x0, original value)	-199 999 to 999 999	0
F12.119	First interpolation point, (y0, replacement value)		
F12.120	Second interpolation point (x1, original value)		
F12.121	Second interpolation point (y1, replacement value)		
	etc. ---->		
F12.148	Last interpolation point, (x15, original value)		
F12.149	First interpolation point, (y15, replacement value)		

F13	Table of linearization for speed 2 (encoder 2)	Range	Default
F13.150	First interpolation point, (x0, original value)	-199 999 to 999 999	0
F13.151	First interpolation point, (y0, replacement value)		
F13.152	Second interpolation point (x1, original value)		
F13.153	Second interpolation point (y1, replacement value)		
	etc. ---->		
F13.180	Last interpolation point, (x15, original value)		
F13.181	Last interpolation point, (y15, replacement value)		

## 7.2.11. Hints for using the linearization function

The subsequent drawing explains the difference between the modes of linearization.

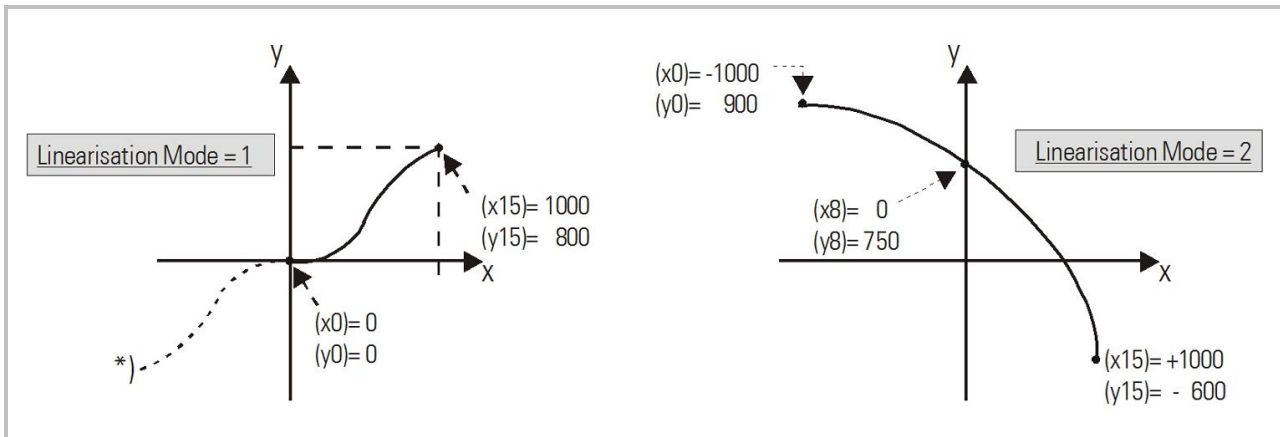

\*) mirror of positive range



- x-registers are to set the numeric value that the unit would display without linearization
- y-registers are to set the numeric value that should be displayed instead, i.e. the (y3) setting will replace the (x3) display value
- between the interpolation points the unit automatically uses linear interpolation
- x- registers have to use continuously increasing values, e.g. the lowest display value must be set to register x0, and the highest display value must be set to x16
- Independent of the selected linearization mode, the possible setting range of all registers x0, y0, ... x16, y16 is always -199999 ... 999999.
- For measuring values outside of the defined linearization range, please note:
  - If the measuring value is lower than (x0), the linearization result will always be (y0).
  - If the measuring value is higher than (x15), the linearization result will always be (y15).

### 7.2.12. Hints for models SD/SA/SR x3x (Display 8 decades)

Compared with a bigger display range models with 8 decade-displays provides a bigger range for some specific parameters. The following table shows the parameters with the changed parameter range.

No.	Menu	Name	Code	Min	Max	Default
0	F01	Preselection 1	00	-19 999 999	99 999 999	1000
1	F01	Preselection 2	01	-19 999 999	99 999 999	2000
2	F01	Preselection 3	02	-19 999 999	99 999 999	3000
3	F01	Preselection 4	03	-19 999 999	99 999 999	4000
11	F02	Offset	A7	-19 999 999	99 999 999	0
27	F03	Set Value 1	C6	-19 999 999	99 999 999	0
37	F04	Set Value 2	D8	-19 999 999	99 999 999	0
85	F09	Analogue Start	J7	-19 999 999	99 999 999	0
86	F09	Analogue End	J8	-19 999 999	99 999 999	10000
101	F12	P1(x)	L1	-19 999 999	99 999 999	0
102		P1(y)	L2	-19 999 999	99 999 999	0
		etc.	etc.	-19 999 999	99 999 999	0
131		P16(x)	O1	-19 999 999	99 999 999	0
132		P16(y)	O2	-19 999 999	99 999 999	0
133	F13	P1(x)	O3	-19 999 999	99 999 999	0
134		P1(y)	O4	-19 999 999	99 999 999	0
		etc.	etc.	-19 999 999	99 999 999	0
163		P16(x)	R3	-19 999 999	99 999 999	0
164		P16(y)	R4	-19 999 999	99 999 999	0

## 8. Practical Examples for Setup and Scaling

For proper scaling of the unit is mandatory to respond to the following questions:

- Which input frequency (Hz) will the encoders produce at a typical speed?
- Which numeric value do we intend to display at this typical speed?  
(sequence of numbers including the decimal positions)
- Is the display characteristics proportional (speed) or reciprocal (time)?

The subsequent settings refer to the illustrations shown in chapter [5](#).

### 8.1. Settings for the Example a) of Chapter 5.1 (Speed Display)

Machine specifications:	Calculations:	Relevant parameters:																
<p><b>Encoder:</b> TTL A, /A, B, /B 4096 ppr.</p> <p><b>Measuring wheel:</b> Circumference = 500 mm (diameter = 159,2 mm)</p> <p><b>Expected Line speed:</b> 0 ... 300 meters/min Desired display value: 0 ... 300,0 m/min (one decimal position)</p>	<p>With a speed of 300 m/min the measuring wheel will rotate at 600 rpm.</p> <p>With a 4096 ppr encoder we will get <math>600 \times 4096 = 2\,457\,600</math> Imp./min equal to 40 960 Imp./sec. (Hz)</p> <p>This means at maximum speed of 300 m/min the encoder frequency is 40 960 Hz.</p> <p>We expect a display value of 3000 (to display 300.0)</p>	<table border="1"> <tr><td>F02.004</td><td>0</td></tr> <tr><td>F02.0005</td><td>1</td></tr> <tr><td>F03.022</td><td>0</td></tr> <tr><td>F03.024</td><td>0,100 (assumed) i.e. display cycle = 0.1 sec.</td></tr> <tr><td>F03.025</td><td>0,10 (display zero with <math>f &lt; 10</math> Hz)</td></tr> <tr><td>F03.027</td><td>40960</td></tr> <tr><td>F03.028</td><td>3000 (= 300.0 with a decimal point)</td></tr> <tr><td>F03.029</td><td>0</td></tr> </table>	F02.004	0	F02.0005	1	F03.022	0	F03.024	0,100 (assumed) i.e. display cycle = 0.1 sec.	F03.025	0,10 (display zero with $f < 10$ Hz)	F03.027	40960	F03.028	3000 (= 300.0 with a decimal point)	F03.029	0
F02.004	0																	
F02.0005	1																	
F03.022	0																	
F03.024	0,100 (assumed) i.e. display cycle = 0.1 sec.																	
F03.025	0,10 (display zero with $f < 10$ Hz)																	
F03.027	40960																	
F03.028	3000 (= 300.0 with a decimal point)																	
F03.029	0																	

### 8.2. Settings for the Example b) of Chapter 5.1 (Baking Time)

Machine specifications:	Calculations:	Relevant parameters:																
<p><b>Proximity switch:</b> Standard PNP 3-wire type</p> <p><b>Sensed pinion:</b> 16 teeth 70 rev. of the pinion = 1 meter of travelling distance</p> <p><b>Furnace length:</b> 60 m</p> <p><b>Range of baking times:</b> from 10 min. up to 2 h</p> <p><b>Desired display format:</b> 01h : 59min : 59sec</p>	<p>To run over the full furnace distance of 60 meters, the proximity will generate a total number of impulses of <math>60 \times 70 \times 16</math> imp. = 67200 impulses totally</p> <p>With maximum speed we expect a transition time of 10 min. equal to 600 sec.</p> <p>With 67200 impulses in 600 seconds our frequency corresponds to 112 Hz</p>	<table border="1"> <tr><td>F02.004</td><td>0</td></tr> <tr><td>F02.0005</td><td>0 (with clock display format decimal points appear automatically)</td></tr> <tr><td>F03.022</td><td>5</td></tr> <tr><td>F03.024</td><td>1,000 (assumed) i.e. display cycle = 1 sec</td></tr> <tr><td>F03.025</td><td>1,00 (frequencies <math>&lt; 1</math> Hz = standstill)</td></tr> <tr><td>F03.027</td><td>112</td></tr> <tr><td>F03.028</td><td>600</td></tr> <tr><td>F03.029</td><td>Use setting "1" first and verify correct display of seconds. Then change over to "3" (clock format)</td></tr> </table>	F02.004	0	F02.0005	0 (with clock display format decimal points appear automatically)	F03.022	5	F03.024	1,000 (assumed) i.e. display cycle = 1 sec	F03.025	1,00 (frequencies $< 1$ Hz = standstill)	F03.027	112	F03.028	600	F03.029	Use setting "1" first and verify correct display of seconds. Then change over to "3" (clock format)
F02.004	0																	
F02.0005	0 (with clock display format decimal points appear automatically)																	
F03.022	5																	
F03.024	1,000 (assumed) i.e. display cycle = 1 sec																	
F03.025	1,00 (frequencies $< 1$ Hz = standstill)																	
F03.027	112																	
F03.028	600																	
F03.029	Use setting "1" first and verify correct display of seconds. Then change over to "3" (clock format)																	

### 8.3. Settings for Example "Differential Speed" of Chapter 5.4

Machine specifications:	Calculations:	Relevant parameters:
<p><b>Both encoders:</b> 1024 ppr quadrature A / B / HTL 24 V</p> <p><b>Circumferences (rolls):</b> all rolls should have the same circumference of 350 mm</p> <p><b>Speeds:</b> Maximum speed on both conveyors is 200 m/min</p> <p><b>Desired display:</b> Differential speed with two decimal positions (format +/-99.99 m/min)</p>	<p>With a maximum speed of 200 m/min and a roll circumference of 0.350 m we will get a roll rpm of 200 m/min : 0,350 m = 571.43 rpm</p> <p>This results in encoder frequencies of 571.43 x 1024 Imp/min = 585 143 Imp./min = 9752.4 Imp./sec. (Hz)</p>	F02.004   3
		F02.005   all = 2
		F02.006
		F02.007
		F02.008   both = 1000
		F02.009   (no re-scaling necessary)
		F02.016   1
		F02.016   It is advisable to synchronize both measuring channels whenever we use combined display results
		F03.022   both = 1
		F04.034
		F03.023   For correct calculation of the difference we must ensure that both speeds have the same direction (both positive or both negative), i.e. either [+Geber1] - [+Geber2] or [-Geber1] - [-Geber2]
		F04.035
		F03.024   both = 0.500 (assumed), i.e. display cycle = 0,5 sec.
		F04.036
F03.025   both = 0,20 (assumed), i.e. speed = 0 with f < 5 Hz		
F04.037		
F03.027   both = 9752 *)		
F04.039		
F03.028   both = 20 000 *) (will appear as 200.00 since we desire to have two decimal positions)		
F04.040		
F03.029   both = 0		
F04.041		

\*) With high accuracy demand we are free to increase the frequency setting tenfold. This will allow to also consider the remaining decimal position of our calculation (i.e. F03.027 = 97524). In order to maintain the proportionality we have then to increase also the desired display value by factor 10 (i.e. F03.028 = 200 000).



## 8.4. Example for Use of the Filter

The subsequent illustrations explain the mode of action of the Filter with different settings. For this explanation we assume:

- Sampling-Time = 10 msec
- The input frequency jumps temporary up to a higher value, and after a time of 60 msec it jumps back to the original value again
- We use in sequence the filter settings 0, 1, 3 and 5

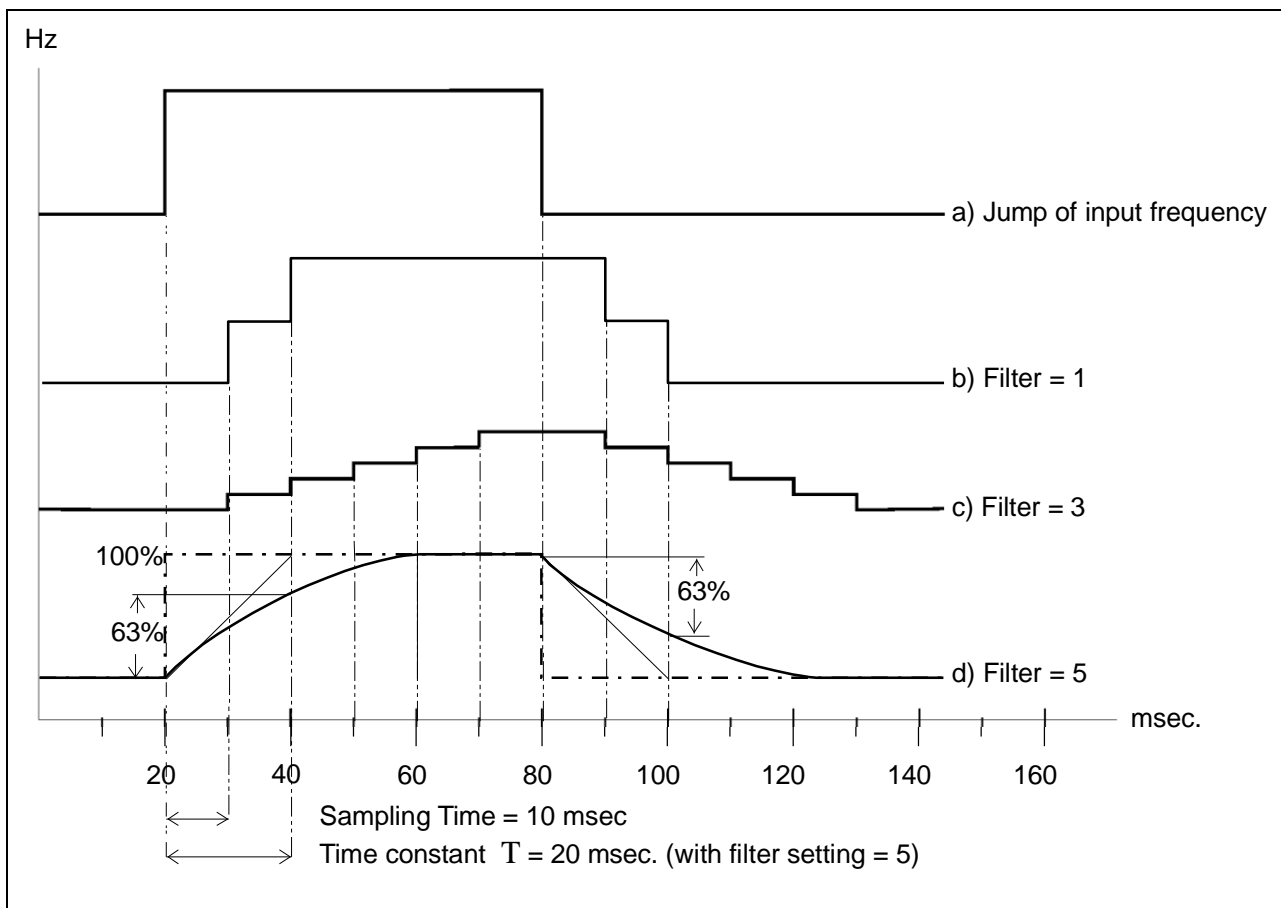

- a) Jump: this shows how the unit would respond with the filter switched off
- b) With Filter set to "1" the unit forms a floating average value over the last two measuring cycles. As a result, after the first sampling period we can only see 50% of the jump and only one cycle later we can see 100%.
- c) With Filter set to "3" the unit forms a floating average value over the last eight measuring cycles. As a result, after the first sampling period we can only see 12.5% (1/8) of the jump and only 7 cycles later we would come up to 100%. However, since the whole jump duration is only 6 cycles long, the display already starts to step back to the previous value before we reached the full jumping level
- d) With Filter set to "5" the unit uses an exponential curve to smoothen the jump. Since the Time Constant of the exponential filter always equals 2 sampling times, we reach 63% of the jumping level after 20 msec.

# 9. Appendix for models SD/SA/SR 6xx

## 9.1. Relay Outputs

All available models are shown in section 2. While models SD 3xx provide high-speed transistor outputs only, all models SD 6xx provide four additional relay outputs, operating in parallel to the high-speed transistor outputs K1 – K4.

All electrical connections of 6xx models are fully similar to the 3xx models, except that with 6xx models the back plane is equipped with an additional 12-position terminal strip.

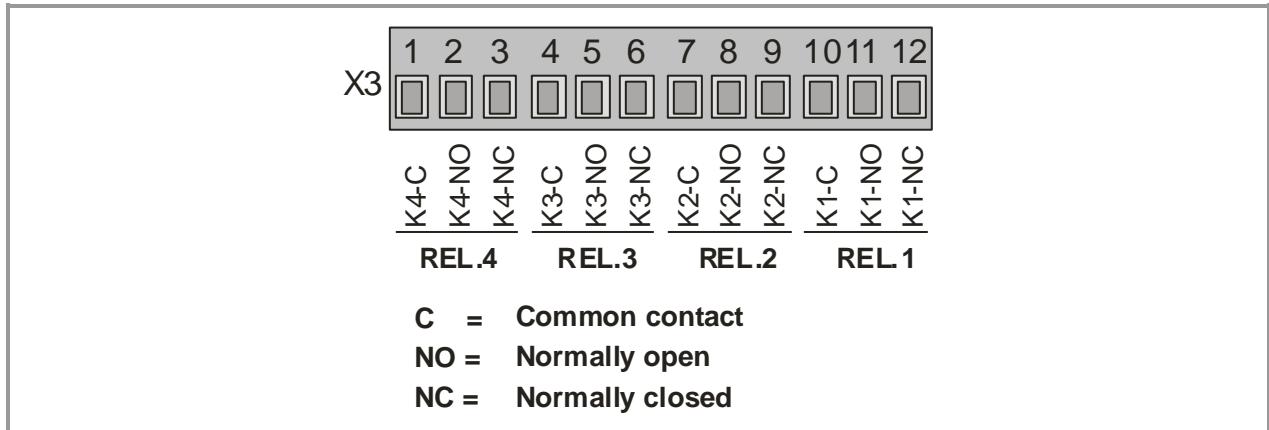

## 9.2. Front Thumbwheel Switches

Moreover, the models shown below provide thumbwheel switches on the front panel, for simple and easy setting of preselection levels. Every row allows in maximum 9 decades and one blank field for separation. The customer is free to specify any desired combination and number of decades individually, which is not wider than totally 10 spaces.

As an example, with model 642 it is possible to specify

“Set1 = 3 decades, Set2 = 6 decades”, or e.g. “Set1 = 8 decades” etc.



Where your order does not clearly state a different array of the thumbwheels, the units will be supplied with 2 x 4 decades respectively 4 x 4 decades

Models 642 can have  
max. 2 switch sets on front

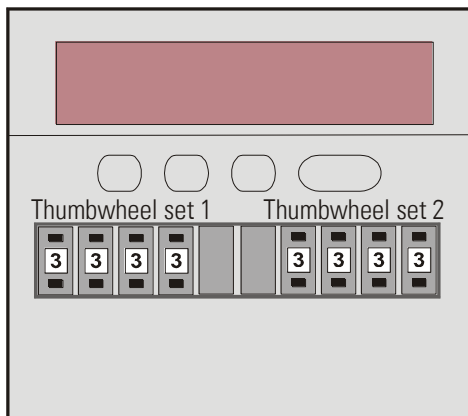

Models 644 can have  
max. 4 switch sets on front

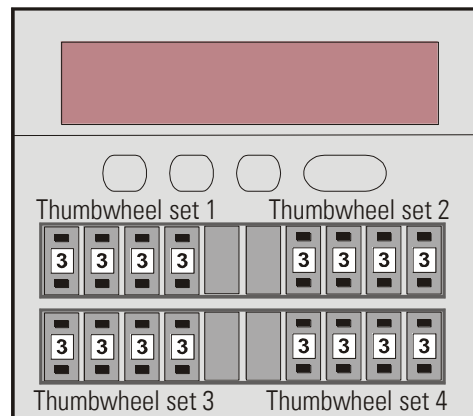

## 9.3. Specific Parameters for Units with Thumbwheel Switches

The following parameter settings apply for units with thumbwheel switches only and are not relevant for all other models:

### 9.3.1. Read and update thumbwheel switch settings

All actual thumbwheel settings are automatically considered when the unit is powered up. However, changes during normal operation will not be considered, unless upon special remote command. This can either be the actuation of one of the front keys, or a command signal to one of the control inputs.

Please see section [7.2.4](#) with the **parameter group F05**.



It is a "must" to assign the function "16" to at least one of the front keys or one of the control inputs. These functions will read the settings of the front switches. Otherwise there will be no way to activate changes of the switch settings during operation.

### 9.3.2. Positive or negative sign of thumbwheel settings

In general and as a default, the front thumbwheel settings are assumed to have a positive sign. Some applications may however require that one or the other setting should be interpreted as a negative value.

Parameter F06.071 allows assigning negative signs to any of the front thumbwheels, following a binary schema as shown in the table below:

Setting of F06.071	00	01	02	03	04	05	06	07	08	09	10	11	12	13	14	15
Sign of Thumbwheel 1	+	-	+	-	+	-	+	-	+	-	+	-	+	-	+	-
Sign of Thumbwheel 2	+	+	-	-	+	+	-	-	+	+	-	-	+	+	-	-
Sign of Thumbwheel 3	+	+	+	+	-	-	-	-	+	+	+	+	-	-	-	-
Sign of Thumbwheel 4	+	+	+	+	+	+	+	+	-	-	-	-	-	-	-	-

### 9.3.3. Assignments between thumbwheels and switching outputs

In general and as a default, thumbwheel switch set No.1 refers to output K1; thumbwheel switch set No.2 refers to output K2 etc. This may be convenient for most of the applications, but also cause inconvenience with some operating modes of the counter.

As an example, when using the "Sum Mode" (see section [5.3](#)), the outputs K1 and K2 are firmly attached to the encoder1 counter and outputs K3 and K4 are firmly attached to the sum of encoder1 and encoder2.

From this follows that, if you use a counter model with two sets of thumbwheels only (thumbwheel set 1 and thumbwheel set 2), you would only have preselection's referring to encoder1, but no thumbwheel access to the sum.

To avoid such kind of limitations, parameter F06.072 allows free assignments between any of the thumbwheel switch sets (switch1 to switch4, see previous figure) and any of the four outputs (K1 to K4)

Setting of parameter F06.072	00	01	02	03	04	05	06	07	08	09	10	11
Thumbwheel set 1 is linked to output	K1	K1	K1	K1	K1	K1	K2	K2	K2	K2	K2	K2
Thumbwheel set 2 is linked to output	K2	K2	K3	K3	K4	K4	K1	K1	K3	K3	K4	K4
Thumbwheel set 3 is linked to output	K3	K4	K4	K2	K2	K3	K3	K4	K4	K1	K1	K3
Thumbwheel set 4 is linked to output	K4	K3	K2	K4	K3	K2	K4	K3	K1	K4	K3	K1

Setting of parameter F06.072	12	13	14	15	16	17	18	19	20	21	22	23
Thumbwheel set 1 is linked to output	K3	K3	K3	K3	K3	K3	K4	K4	K4	K4	K4	K4
Thumbwheel set 2 is linked to output	K1	K1	K2	K2	K4	K4	K1	K1	K2	K2	K3	K3
Thumbwheel set 3 is linked to output	K2	K4	K4	K1	K1	K2	K2	K3	K3	K1	K1	K2
Thumbwheel set 4 is linked to output	K4	K2	K1	K4	K2	K1	K3	K2	K1	K3	K2	K1

# 10. Appendix: Serial Communication Details

Serial communication with the counter can be used for the following purposes:

- PC setup of the counter, using the OS32 Operator software
- Automatic and cyclic transmission of counter data to remote devices like PC, PLC or Data Logger
- Communication via PC or PLC, using the communication protocol

This section describes the essential and basic communication features only. Full details are available from the special SERPRO manual.

## 10.1. Setup of the Counter by PC

Connect the counter to your PC as shown in section 4.6 of this manual. Start the OS32 Operator software. After a short initializing time you will see the following screen:

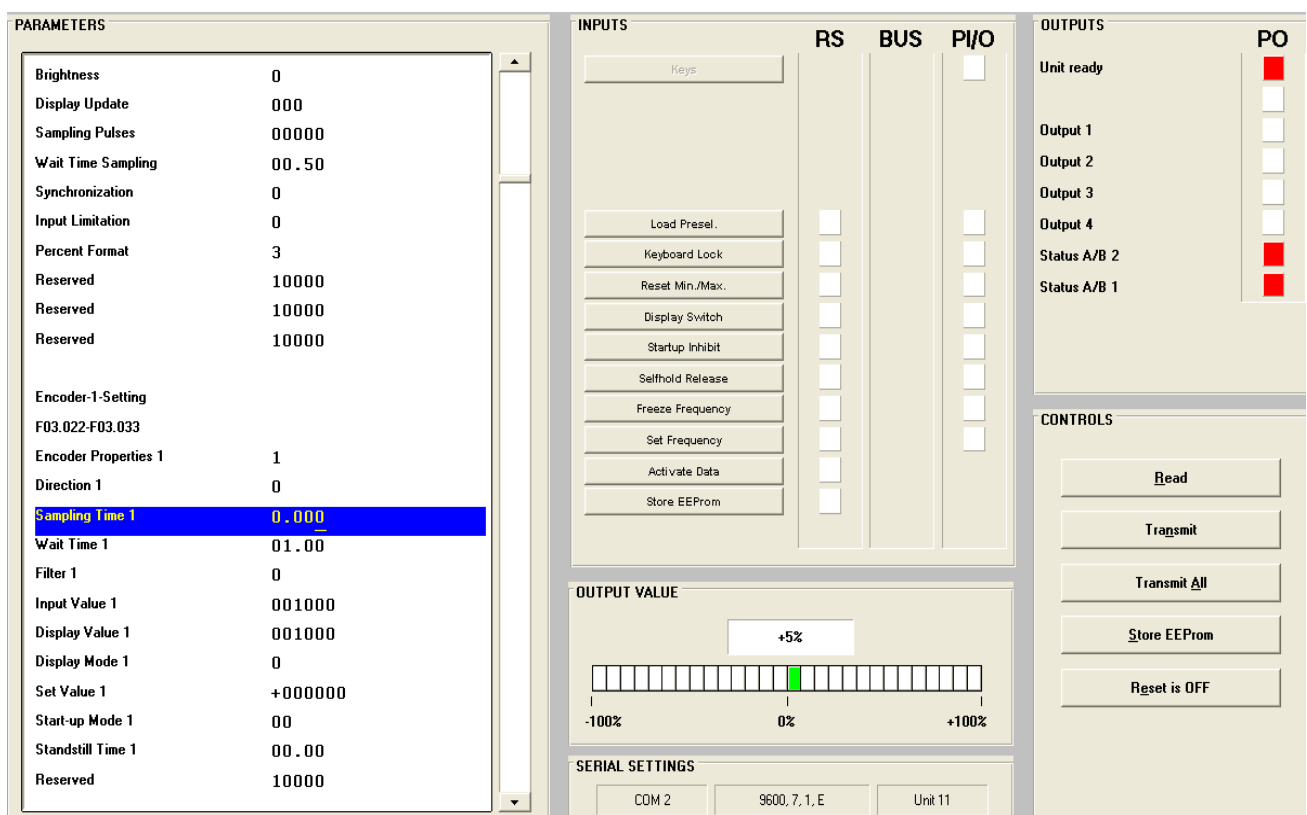

If your screen remains empty and the headline of your PC says „OFFLINE“, select „Comms“ of the menu bar and check your serial communication settings.

The edit field on the left shows all actual parameters and provides full editing function. The „File“ menu allows to store complete sets of parameters for printout or for download to a counter.

When editing parameters, please use the ENTER key of your PC after each entry, to ensure storage of your data to the counter.

## 10.2. Automatic and Cyclic Data Transmission

Set any cycle time unequal to zero to parameter F10.110.

Set the serial access code of the register you would like to transmit to parameter F10.111. In theory you could transmit any of the internal registers by serial link, however only the following registers make really sense:

<b>F10.111 = 6 :</b>	Actual speed of encoder 1
<b>= 7 :</b>	Actual speed of encoder 2
<b>= 8 :</b>	Actual analogue output voltage (SA models only)
<b>= 9 :</b>	Latest minimum value (minimum record memory)
<b>= 10 :</b>	Latest maximum value (maximum record memory)
<b>= 14 :</b>	Actual value indicated in the display

Dependent on the setting of parameter F10.109 the unit transmits one of the following data strings, under cycle control of the timer:

(xxxx = counter data\*, LF = Line Feed <hex. 0A>, CR = Carriage Return <hex 0D>)

\*) Leading zeros will not be transmitted

	(Unit No.)											
<b>F10.109 = 0 :</b>	1	1	+/-	X	X	X	X	X	X	X	LF	CR
<b>F10.109 = 1 :</b>			+/-	X	X	X	X	X	X	X	LF	CR

## 10.3. Communication Protocol

When communicating with the unit via protocol, you have full read/write access to all internal parameters, states and actual counter values. The protocol uses the DRIVECOM standard according to DIN ISO 1745. A list with the most frequently used serial access codes can be found in the previous section.

To request data from the counter, the following request string must be sent:

EOT	AD1	AD2	C1	C2	ENQ
EOT = Control character (Hex 04)					
AD1 = Unit address, High Byte					
AD2 = Unit address, Low Byte					
C1 = Register code to read, High Byte					
C2 = Register code to read, Low Byte					
ENQ = Control character (Hex 05)					

The example shows how to request for transmission of the actual encoder 1 speed (register code :9), from a unit with unit address 11:

<b>ASCII-Code:</b>	EOT	1	1	:	6	ENQ
<b>Hexadecimal:</b>	04	31	31	3A	39	05
<b>Binary:</b>	0000 0100	0011 0001	0011 0001	0011 1010	0011 1001	0000 0101

Upon correct request, the counter will respond:

STX	C1	C2	x x x x x x x	ETX	BCC
STX = Control character (Hex 02)					
C1 = Register code to read, High Byte					
C2 = Register code to read, Low Byte					
xxxxx = Counter data *)					
ETX = Control character (Hex 03)					
BCC = Block check character					

\*) Leading zeros will not be transmitted

The Block-Check-Character represents the EXCLUSIVE-OR function of all characters from C1 to ETX (both comprised).

To write to a parameter, you have to send the following string:

EOT	AD1	AD2	STX	C1	C2	x x x x x x x	ETX	BCC
EOT = Control character (Hex 04)								
AD1 = Unit address, High Byte								
AD2 = Unit address, Low Byte								
STX = Control character (Hex 02)								
C1 = Register code to write, High Byte								
C2 = Register code to write, Low Byte								
xxxxx = Value of the parameter								
ETX = Control character (Hex 03)								
BCC = Block check character								

Upon correct receipt the unit will respond by ACK, otherwise by NAK.

Every new parameter sent will first go to a buffer memory, without affecting the actual measuring process. This function enables the user, during normal measuring operation, to prepare a complete new parameter set in the background.

To activate transmitted parameters, you must write the numeric value "1" to the "Activate Data" register. This immediately activates all changed settings at the same time.

Where you like the new parameters to remain valid also after the next power up of the unit, you still have to write the numeric value "1" to the „Store EEPROM“ register. This will store all new data to the EEPROM of the unit. Otherwise, after power down the unit would return with the previous parameter set.

## 10.4. Serial Register Codes

### 10.4.1. Communication Commands

Function	Code
Activate Data	67
Store EEPROM	68

These commands have to be sent to the unit every time after one or several new parameters have been transmitted, in order to activate or to store the new values. Both commands are "dynamic", i.e. it is sufficient to just send the data value "1" to the corresponding code position.

Example: send the command "Activate Date" to the unit with Unit No. 11:

<b>ASCII</b>	EOT	1	1	STX	6	7	1	ETX	BCC
<b>Hex</b>	04	31	31	02	36	37	31	03	33

### 10.4.2. Control Commands

Serial command	Code
Read thumbwheel switches (see F05.050 = 16) *)	59
Hardware keypad disable (see F05.050 = 15) *)	60
Clear min/max record memory (see F05.050 = 14) *)	61
Cycle the display (see F05.050 = 13) *)	62
Remote start-up delay (see F05.050 = 12) *)	63
Release latch / maintain of outputs and relays (see F10.114) *)	64
Freeze encoder frequencies (see F10.113) *)	65
Substitute encoder frequencies (see F10.112) *)	66
Activate Data (activation of serial transmit parameters) **)	67
Store EEPROM (storage of parameters in EEPROM) **)	68

\*) Sending data value "1" to the corresponding location will switch the command persistently ON until sending again the data "0" to the same location

\*\*) Sending data value "1" to the corresponding location will switch the command ON and the bit will automatically reset to 0 after execution

Example: Switch on the hardware keypad lock (disable keypad of unit No. 11):

<b>ASCII</b>	EOT	1	1	STX	6	0	1	ETX	BCC
<b>Hex</b>	04	31	31	02	36	30	31	03	34

Switch off the hardware keypad lock (enable keypad of unit No. 11 again)

<b>ASCII</b>	EOT	1	1	STX	6	0	0	ETX	BCC
<b>Hex</b>	04	31	31	02	36	30	30	03	35



### 10.4.3. Code list of all parameters

No.	Menu	Name	Code	Min	Max	Default
0	F01	Preselection 1	00	-199999	999999	1000
1		Preselection 2	01	-199999	999999	2000
2		Preselection 3	02	-199999	999999	3000
3		Preselection 4	03	-199999	999999	4000
4	F02	Operational Mode	A0	0	8	1
5		Decimal Point 1	A1	0	5	0
6		Decimal Point 2	A2	0	5	0
7		Decimal Point 12	A3	0	5	0
8		Display Value	A4	1	999999	1000
9		New Display Value	A5	1	999999	1000
10		Display Mode	A6	0	3	0
11		Offset	A7	-199999	999999	0
12		Brightness	A8	0	4	0
13		Display Update	A9	0	100	0
14		Sampling Pulses	B0	0	30000	0
15		Wait Time Sampling	B1	0	9999	50
16		Synchronization	B2	0	1	0
17		Input Limitation	B3	0	3	0
18		Percent Format	B4	0	3	0
19		F03	Encoder Properties 1	B8	0	5
20	Direction 1		B9	0	1	0
21	Sampling Time 1		C0	0	9999	1
22	Wait Time 1		C1	1	9999	100
23	Filter 1		C2	0	8	0
24	Input Value 1		C3	1	999999	1000
25	Display Value 1		C4	1	999999	1000
26	Display Mode 1		C5	0	3	0
27	Set Value 1		C6	-199999	999999	0
28	Start-up Mode 1		C7	0	10	0
29	Standstill Time 1		C8	0	9999	0

No.	Menu	Name	Code	Min	Max	Default
30	F04	Encoder Properties 2	D0	0	5	1
31		Direction 2	D1	0	1	0
32		Sampling Time 2	D2	0	9999	1
33		Wait Time 2	D3	1	9999	100
34		Filter 2	D4	0	8	0
39		Input Value 2	D5	1	999999	1000
35		Display Value 2	D6	1	999999	1000
36		Display Mode 2	D7	0	3	0
37		Set Value 2	D8	-199999	999999	0
38		Start-up Mode 2	D9	0	10	0
39		Standstill Time 2	E0	0	9999	0
40		F05	Key Up Function	E2	0	17
41	Key Down Function		E3	0	17	0
42	Key Enter Function		E4	0	17	0
43	Input 1 Configuration		E5	0	7	0
44	Input 1 Function		E6	0	17	0
45	Input 2 Configuration		E7	0	7	0
46	Input 2 Function		E8	0	17	0
47	Input 3 Configuration		E9	0	7	0
48	Input 3 Function		F0	0	17	0
49	Input 4 Configuration		F1	0	3	0
50	Input 4 Function		F2	0	17	0
51	F06	Pulse Time 1	F4	0	999	0
52		Pulse Time 2	F5	0	999	0
53		Pulse Time 3	F6	0	999	0
54		Pulse Time 4	F7	0	999	0
55		Hysteresis 1	F8	0	99999	0
56		Hysteresis 2	F9	0	99999	0
57		Hysteresis 3	G0	0	99999	0
58		Hysteresis 4	G1	0	99999	0
59		Preselection Mode 1	G2	0	8	0
60		Preselection Mode 2	G3	0	8	0
61		Preselection Mode 3	G4	0	8	0
62		Preselection Mode 4	G5	0	8	0
63		Output Polarity	G6	0	15	0
64		Thumbwheel Sign	G7	0	15	0
65		Thumbwheel Configuration	G8	0	23	0
66		Output Lock	G9	0	1	0
67		Start-up Relay	H0	0	15	0
68		Lock Relay	H1	0	31	0

No.	Menu	Name	Code	Min	Max	Default
69	F07	Protect F01	H4	0	999999	0
70		Protect F02	H5	0	999999	0
71		Protect F03	H6	0	999999	0
72		Protect F04	H7	0	999999	0
73		Protect F05	H8	0	999999	0
74		Protect F06	H9	0	999999	0
75		Protect F07	I0	0	999999	6078
76		Protect F08	I1	0	999999	6078
77		Protect F09	I2	0	999999	0
78		Protect F10	I3	0	999999	0
79		Protect F11	I4	0	999999	6078
80		Protect F12	I5	0	999999	0
81		Protect F13	I6	0	999999	0
82	F08	Trigger Threshold 1	J1	30	250	166
83		Trigger Threshold 2	J2	30	250	166
84	F09	Analogue Format	J6	0	3	0
85		Analogue Start	J7	-199999	999999	0
86		Analogue End	J8	-199999	999999	10000
87		Analogue Swing	J9	1	1000	100
88		Analogue Offset	K0	-10000	10000	0
89		Analogue Assignment	K1	0	5	0
90	F10	Unit Number	90	0	99	11
91		Serial Baud Rate	91	0	6	0
92		Serial Format	92	0	9	0
93		Serial Protocol	K2	0	1	1
94		Serial Timer (s)	K3	0	99999	0
95		Register Code	K4	0	26	14
96		Command Set	K5	0	3	0
97		Command Freeze	K6	0	3	0
98		Command Selfhold	K7	0	15	0

No.	Menu	Name	Code	Min	Max	Default
99	F11	Linearisation Mode 1	K9	0	2	0
100		Linearisation Mode 2	L0	0	2	0
101	F12	P1(x)	L1	-199999	999999	0
102		P1(y)	L2			
		etc.	etc.			
131		P16(x)	01			
132		P16(y)	02			
133	F13	P1(x)	03	-199999	999999	0
134		P1(y)	04			
		etc.	etc.			
163		P16(x)	R3			
164		P16(y)	R4			

#### 10.4.4. Code list of commands

No.	Name	Code	Cmd Bit
1	Load Presel.	59	0100
2	Keyboard Lock	60	0080
3	Reset Min./Max.	61	0040
4	Display Switch	62	0020
5	Startup Inhibit	63	0010
6	Selfhold Release	64	0008
7	Freeze Frequency	65	0004
8	Set Frequency	66	0002
9	Activate Data	67	1000
10	Store EEPROM	68	0001

#### 10.4.5. Code list of outputs

No.	Name	Cmd Bit
0	Unit ready	0001
1	Output 1	0004
2	Output 2	0008
3	Output 3	0010
4	Output 4	0020
5	Status A/B 2	0040
6	Status A/B 1	0080

#### 10.4.6. Code list of variables

Name	Serial Code	
	High Byte	Low Byte
Actual speed of encoder 1	:	9
Actual speed of encoder 2	;	0
Actual analogue output voltage (SA models only)	:	8
Latest minimum value (minimum record memory)	<	0
Latest maximum value (maximum record memory)	<	1
Actual value indicated in the display	;	4

# 11. Technical specifications

<b>Power supply:</b>	Input voltage (AC): Power consumption (AC): Input voltage (DC): Protection circuit (DC): Ripple (DC): Consumption: Connections:	24 VAC (+/- 10 %) 15 VA 24 VDC (17 ... 40 VDC) reverse polarity protection ≤ 10 % at 24 VDC approx. 100 mA (unloaded) AC: screw terminals, 2.5 mm <sup>2</sup> / AWG 14 DC: screw terminals, 1.5 mm <sup>2</sup> / AWG 16
<b>Encoder supply:</b>	Number of outputs: Output voltage 1: Output current 1: Output voltage 2: Output current 2: Connections:	je 2 x 24 V und 2 x 5.2 V 24 VDC max. 120 mA per output 5.2 VDC max. 150 mA per output screw terminals, 1.5 mm <sup>2</sup> / AWG 16
<b>Incremental inputs:</b>	Number of inputs: Input logic: Signal levels:  Channels: Frequency:  Internal resistance: Connections:	2 PNP/NPN/Namur HTL: LOW 0 ... 3.5 V, HIGH 10 ... 30 V TTL: LOW 0 ... 0.8 V, HIGH 2.4 ... 5 V RS422: differential voltage > 1V each A, /A, B, /B max. 1 MHz with RS422 / TTL symmetrical max. 200 kHz with HTL / TTL asymmetrical Ri = 8.5 kOhm / channel (pull-down) screw terminals, 1.5 mm <sup>2</sup> / AWG 16
<b>Control inputs:</b>	Number of inputs: Input logic: Signal levels: Functions: Minimum pulse time: Internal resistance: Connections:	4 PNP/NPN/Namur HTL (standard): LOW 0 ... 2.5 V, HIGH 10 ... 30 V arbitrary (depends on operational mode) 50 μs Ri = 3.3 kOhm screw terminals, 1.5 mm <sup>2</sup> / AWG 16
<b>Analog output:</b> (only SA)	Voltage output: mA output: Resolution: Accuracy: Reaction time: Connections:	+/- 10 V, max. 2 mA 0 / 4 ... 20 mA (burden: max. 270 Ohm) 14 bit (±13 bit) 0.1 % < 1 ms <b>(a)</b> screw terminals, 1.5 mm <sup>2</sup> / AWG 16
<b>Control outputs:</b>	Number of outputs: Signal levels: Output current: Reaction time: Protection circuit: Connections:	4 fast transistor outputs <b>(b)</b> 5 ... 30 V / PNP max. 350 mA / channel < 1 ms <b>(a)</b> short circuit proof screw terminals, 1.5 mm <sup>2</sup> / AWG 16
<b>Relay outputs:</b> (only SA/SD/SR6xx)	Number of outputs: Switching capacity: Connections:	4 potential free changeovers <b>(b)</b> 250 VAC / 1 A / 250 VA oder 100 VDC / 1 A / 100 W screw terminals, 2.5 mm <sup>2</sup> / AWG 14

**(a)** Continuous serial communication may temporary increase response times  
Overall response = measuring time + response time

**(b)** Diode or RC filtering is mandatory when switching inductive loads

## Continuation - Technical specifications

<b>Serial interface:</b>	Format: Baud rates (selectable): Operational modes: Connections:	SD / SA series: only RS232 SR series: RS232, switchable to RS485 (2-wire) 600, 1200, 2400, 4800, 9600, 19200, 38400 Baud PC or printer mode screw terminals, 1.5 mm <sup>2</sup> / AWG 16
<b>Display:</b>	Type: Characteristic: Digit height:	6 resp. 8 digit LED display high-efficiency orange 15 mm resp. 10 mm / 0.59055" resp. 0.3937"
<b>Housing:</b>	Type/Material: Mounting: Dimension 3xx series:  Dimension 6xx series:  Protection class:  Weight:	Norly UL94-V-0 / plastic panel outer dimensions (w x h x d): 110 x 48 x 141 mm / 4.33 x 1.89 x 5.55" cut out (w x h): 91 x 44 mm / 3.59 x 1.73"  outer dimensions (w x h): 110 x 96 x 141 mm / 4.33 x 3.78 x 5.55" cut out (w x h): 89 x 91 mm / 3.50 x 3.59"  units without BCD switches: front: IP 65 / rear: IP20 units with BCD switches: front: IP 20* / rear: IP20 * (also IP65 when using the plexiglass cover part # 64026)  3xx series: approx. 250 g 6xx series: approx. 480 g
<b>Ambient temperature:</b>	Operation: Storage:	0 °C ... +45 °C / +32 ... +113 °F (not condensing) -25 °C ... +70 °C / -13 ... +158 °F (not condensing)
<b>Conformity and standards:</b>	EMC 2004/108/EC: LV 2006/95/EC Guideline 2011/65/EU:	EN 61000-6-2, EN 61000-6-3, EN 61000-6-4 EN 61010-1 RoHS-conform

# 12. Dimensions

## 12.1. Models 340:

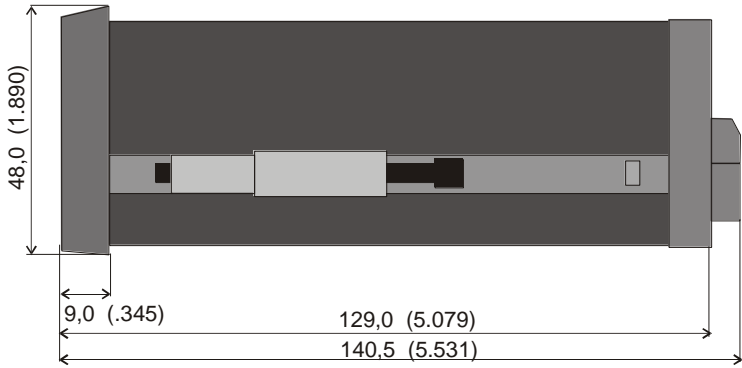
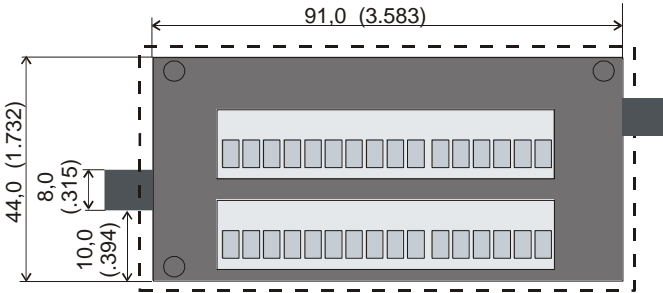
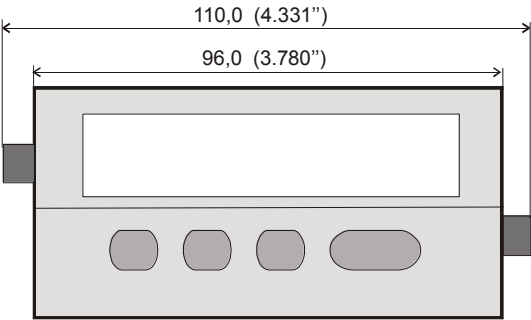

Panel cut out: w x h = 91 x 44 mm (3.583 x 1.732")

## 12.2. Models 640 to 644:

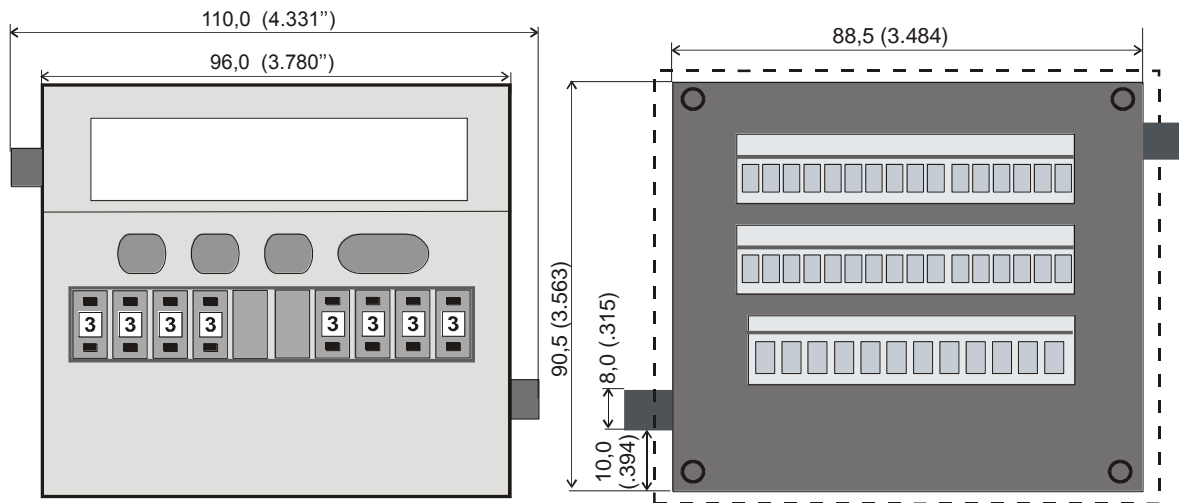

With optional plexi glass cover  
for protection class IP65  
(mks part # 64026)

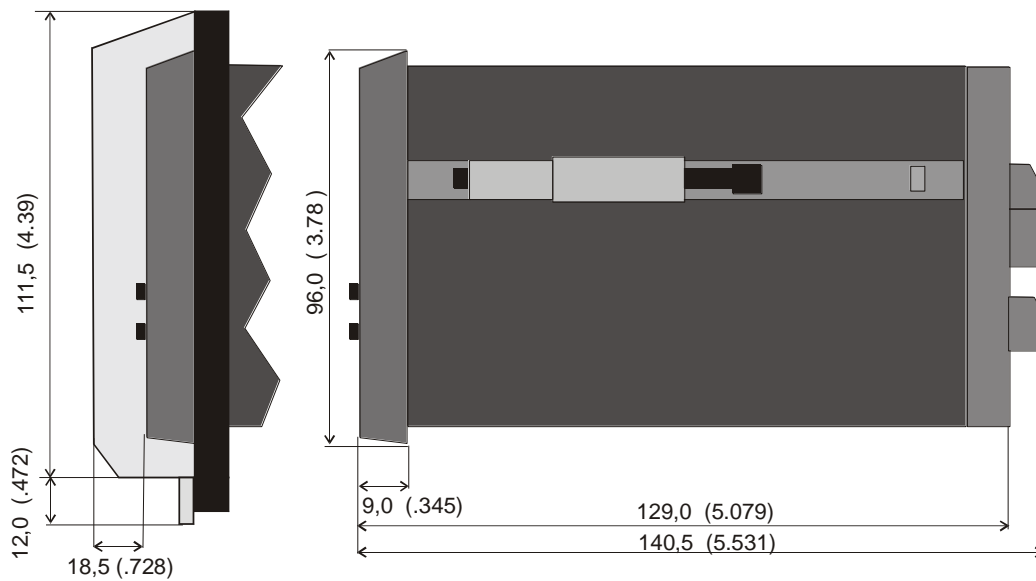

Panel cut out: w x h = 89 x 91 mm (3.504" x 3.583")