

Key Features

- 2-wire, sine wave output, clipped at ± 20 V level
- 1" NPT conduit port (917A)
- Non-contact, large gap distance sensing
- Work with magnetic pulser discs/wraps
- 916A – Optional EZ-3/4in mounting bracket and mounting magnet available
- 917A – Optional EZ-100 mounting bracket and mounting magnet available



916A

917A

Description

916A sensors have a 3/4" threaded aluminum body, are supplied with a mounting bracket and jam nuts, and are recommended for use with pulser discs and split collar pulser wraps.

917A sensors are mounted in a rugged cast aluminum enclosure, are supplied with a mounting bracket, and are recommended for use with pulser discs and split collar pulser wraps.

Principle of Operation

The output signal from the 916A and 917A analog sensors is clipped at 20 VAC. These sensors switch high and low in the presence of alternating magnetic fields and generate a sine wave signal when used with a pulse generator, which have evenly spaced magnets of alternating polarity.

916A and 917A analog sensors allow for a large gap distance of $1/4" \pm 1/8"$ between the sensing surface and the pulse generator's target magnets. Standard 916A and 917A sensors come with 10 feet of 2-wire shielded PVC cable and can be mounted up to 1,500 feet from the control unit (i.e. speed switch or tachometer).

Dimensions

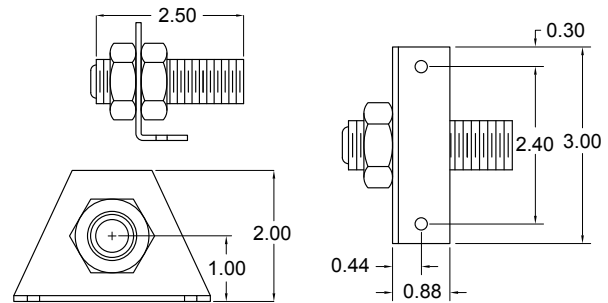

916A Standard Triangle Bracket
(Square Bracket Available)

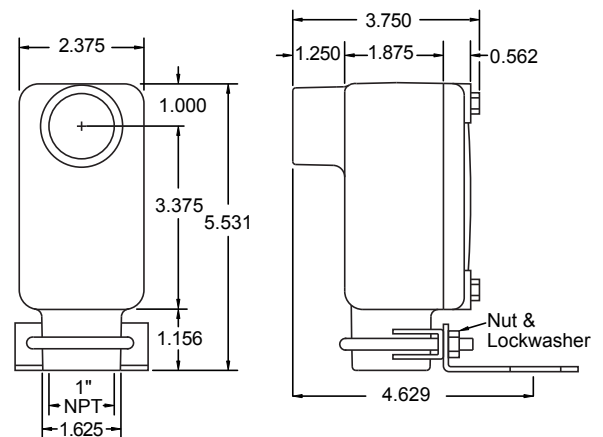

917A Standard

916A/917A Analog Specifications

Product	
Operating Frequency	0 Hz to 20 KHz
Operating Temperature	-40 °F to +140 °F -40 °C to +60 °C
Gap Distance	1/4" ± 1/8"
Distance to Input Device	1,500 feet maximum
Cable (22 AWG)	2-conductor shielded, 22 AWG
Standard Cable Length	10 ft
Wiring Code	White = Signal Black = Common
Output Type	Sinusoidal wave limited to 20 VAC by zener diode
Material	916A: Aluminum, 3/4"-16 UNF threads 917A: Cast aluminum housing

Specifications subject to change without notice.

Ordering

916A

Model	Part Number
916A, Triangle Bracket, 10' PVC Cable – Standard	775-000801
916A, Triangle Bracket, 50' PVC Cable	775-000802
916A, Triangle Bracket, 100' PVC Cable	775-000803
916A, Triangle Bracket, 10' Teflon Cable	775-000804
916A, Triangle Bracket, 50' Teflon Cable	775-000805
916A, Triangle Bracket, 100' Teflon Cable	775-000806
916A, Square Bracket, 10' PVC Cable	775-000807
916A, Square Bracket, 50' PVC Cable	775-000808
916A, Square Bracket, 100' PVC Cable	775-000809
916A SS, Stainless Steel, 10' PVC Cable	775-000810

917A

917A, 10' PVC Cable – Standard	775-000811
917A, 50' PVC Cable	775-000812
917A, 100' PVC Cable	775-000813

916A/917A Analog Standard System

- Shaft Speed Pulse Generator

These are the most popular system components. Many other options are available.

System Options	Part Number
Standard 255 Nylon Pulser Disc, 4" Diameter, 16 Magnets	700-000200
Split Collar Pulser Wrap (PVC, Aluminum, Stainless Steel)	Custom (See Website)

Other Options	Part Number
EZ-3/4in Bracket Assembly (916A)	810-000040
EZ-100 Bracket Assembly (917A)	810-000001
MM-1.25 Mounting Magnet (must use EZ-3/4in Bracket Assembly)	810-000060
MM-2.00 Mounting Magnet (must use EZ-100 Bracket Assembly)	810-000050
Standard Disc Guard	725-005300
EZ-Mount Disc Guard	725-005200
EZ-Mount Lower Disc Guard	725-005201



EZ-100 Mounting Option (917A)



EZ-3/4in Mounting Option (916A)



Mounting Magnet Options (must be used with EZ-Mounts)



Standard Disc Guard

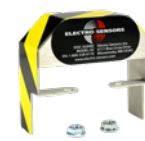

EZ-Mount Disc Guard



Lower EZ-Mount Guard

Customization

If one of our standard products does not meet your specifications, please call one of our applications specialists. Many of our products can be customized to fit specific needs.

Additional Information

Please call Electro-Sensors for more information.