

Model TA

Conveyor Belt Alignment System

PRINCIPLE OF OPERATION

The Model TA Conveyor Belt Alignment Control protects conveyor belts from damage due to belt misalignment or runoff. These controls are used in pairs with one control placed on each side of the conveyor belt. Each control unit can be equipped with two micro-switches to produce signals indicating belt misalignment at two deviation points. The first signal point could be used to indicate small belt deviation by sounding an alarm. The second signal point could be used to guard against extreme belt runoff by shutting down the conveyor.

Each control consists of aluminum housing with a red epoxy coated roller. The roller is adjustable up to 90° in both directions and is positioned approximately 1" from the conveyor belt. The micro-switch actuation points are adjustable from 0° to 45° by a simple change of the actuating cam(s). The Model TA can be furnished with general purpose or explosion proof construction. Cast iron and epoxy coated housings are also available.

RECOMMENDED NUMBER OF UNITS

A minimum of four alignment controls is required for each conveyor belt, with one on each side of the belt near the head and tail pulleys. For conveyors greater than 1,500 feet (457 meters) long, an additional four alignment controls are required, evenly spaced, one on each side of the carrying and return belt.

INSTALLATION INSTRUCTIONS

Model TA control units are always used in pairs with one placed on each side of the conveyor belt, usually a pair at each of the head and tail ends of the conveyor. Additional pairs of Model TA units may be placed at other points along the conveyor, such as horizontal curve sections.

The micro-switch(es) can be wired to trigger a warning signal or be connected directly to the motor starter circuit to stop a conveyor.

The control unit should be mounted on supports so that the roller is positioned perpendicular to the conveyor belt, and positioned to intercept the conveyor belt at its midpoint. The roller clamp may be loosened to pivot the roller into the proper position. The roller is 9-3/4" high, and the point of interception should be at the 4-7/8" point. Control units should not be mounted too close to the belt because false signals could result. In most applications, the controls could be mounted approximately 1" from the belt, eliminating false signals while still protecting the belt against wide deviations.

Field wiring must meet or exceed the requirements of the National Electrical Code and any other agency or authority having jurisdiction over the installation.

ROLLER POSITION AND MICRO-SWITCH ACTUATION SETUP

The Model TA is shipped with the switch cam centered with the roller arm. During the installation, the switch cam and the roller arm should be re-positioned to ensure switch actuation at the desired roller positions.

1. Roller Position

Loosen the roller clamp and pivot the roller so that it is perpendicular to the belt at the midpoint of the roller. Then tighten the roller clamp.

- Position the housing so the roller is 1" from the edge of the conveyor belt. Then fasten the mounting feet.

3. Switch Cam Adjustment

Lock out all power to the switch unit and remove the cover. Use the 3/32 hex wrench provided to loosen the #10-32 set screw on the switch cam.

- Pivot roller in the desired amount away from the belt for alarm or shutdown.

- Adjust cam in same direction as the roller will move until the micro-switch just trips. Then lock the setscrew.

- Pivot the roller in the desired amount for second trip point if needed.

- Adjust the second cam as in step 5.

Figure 1: Control Accuation Example

APPROXIMATE SWITCH CAM ACTUATION POSITIONS

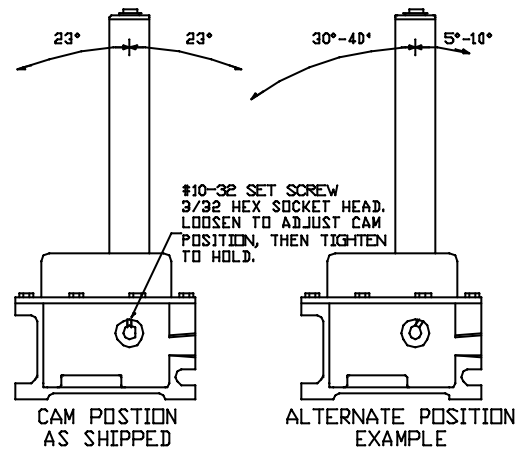
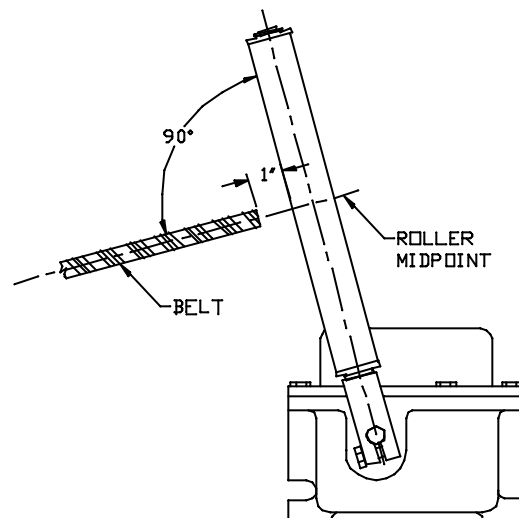

Figure 2: Roller and Belt Position



TECHNICAL INFORMATION

1. Individual Switch Contact Ratings:

SPDT switches:	DPDT switches:
20 Amps, 125/250/480 VAC	15 Amps, 125/250 VAC
10 Amps, 125 VAC Inductive	N/A
1 hp, 125 VAC	3/4 hp, 125 VAC
2 hp, 250 VAC	1 1/2 hp, 250 VAC
1/2 Amp, 24 VDC	N/A
1/2 Amp, 125 VDC	N/A
1/4 Amp, 250 VDC	N/A

- Conduit opening: One 3/4" NPT standard opening is built-in.
- Actuating Arm:
Roller is red epoxy coated steel with stainless steel shaft.
Roller arm travel is 90° in both directions from vertical.
- External Hardware: stainless steel
- Operating Temperature Range: -40°F to 150°F
- Housing/enclosure: cast aluminium, cast iron optional.

WIRING

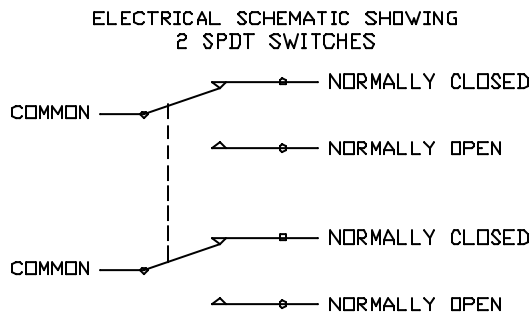

Figure 3: SPDT 2-Switch Schematic

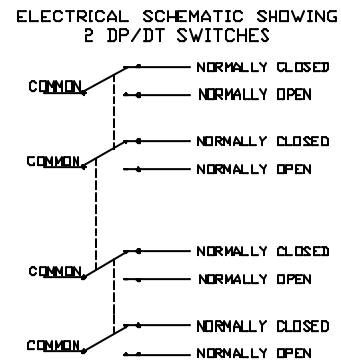
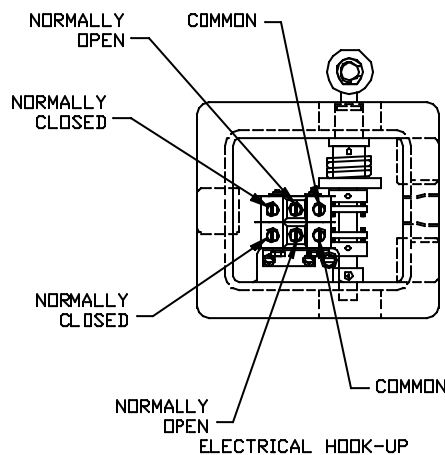

Figure 4: DPDT 2-Switch Schematic

Figure 5: Terminal
Identification (SPDT)



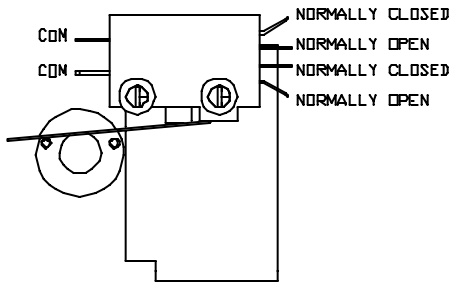
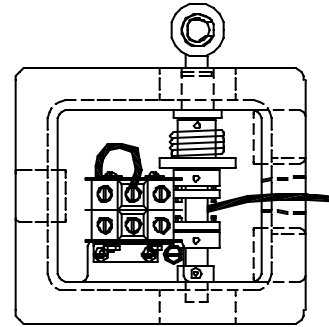

Figure 6: Terminal Identification (DPDT)

To properly wire to the micro-switches on the Model TA, route incoming wires under the shaft and micro-switches to the rear right side of the switches. Avoid contact with the micro-switch levers and other moving parts inside enclosure.

Figure 7: Wire Routing



DIMENSIONS
Figure 8: Dimensions and Mounting.

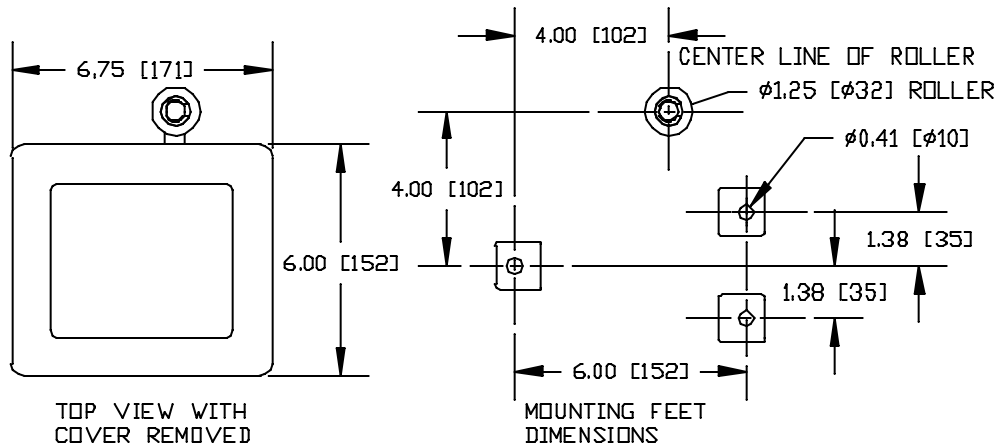

Figure 9: Dimensions and Roller Travel

