

Key Features

- Large Sensor Gap Options
- Wide Range of Available Pulse Per Revolution (PPR)
- Multiple monitoring planes and materials
- Works Through Excessive Dirt, Grease, Dust, or Grime
- NEMA C Frame Ring Kits



Standard Pulser Discs: Standard shaft-end Pulser Discs are made of nylon, PVC, aluminum, or stainless steel and have magnets of alternating polarity (N-S-N-S...) embedded on the outside face or the edge circumference. Pulser discs work through dust, grease and grime and are available with many different materials and pulse configurations. Simply center-drill and tap the end of the shaft to be monitored and secure the Pulser Disc onto the shaft.

Compatible with Electro-Sensors Products, including speed switches with sensing head.

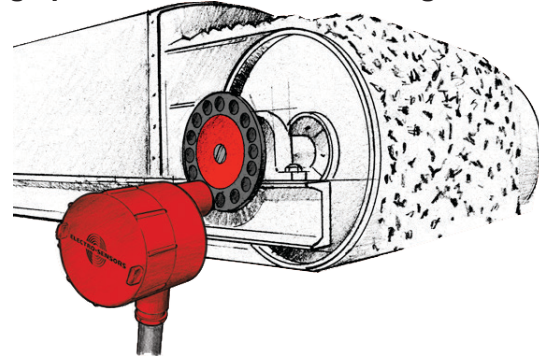

EZ-18 & EZ 3/4 Enclosed Pulse Generator:

The EZ-18mm (18mm thread) and the EZ-3/4in (3/4 in thread) Easy Mount Bracket Assemblies are used with Electro-Sensors speed sensors to generate pulses or 4-20 mA signals for use with display meters, speed switches, or PLC inputs. The EZ-18mm and EZ-3/4in mount directly to the shaft so no other mounting brackets are needed. A securing strap is also provided. EZ Shaft mounts also have the option to use a mounting magnet, which makes attachment to shaft simple and easy.

Compatible with 906, 932, ST420, and Series 18 barrel sensors.

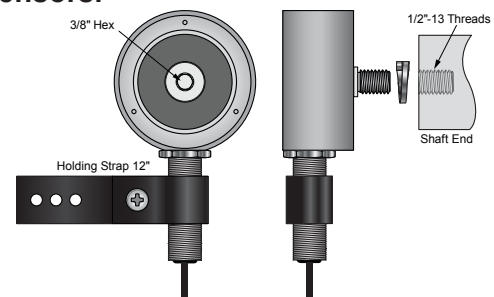

HPR Shaft RPM Sensor and EZ 1 Mag Mount Installation

Pulser Wraps: Pulser Wraps are PVC, aluminum, or stainless steel split collars with magnets mounted on the outside circumference. The magnets serve as targets for Hall-Effect and Magneto-resistive sensors that switch when exposed to magnetic fields. All wraps are custom machined to the diameter of the monitored shaft and are split into halves. This splitting process allows the wrap to clamp tightly onto the shaft without tearing down any equipment to install them. The halves are secured around the shaft with recessed Allen-head socket screws supplied with each wrap. Pulser Wraps provide magnetic targets that are strong enough to allow large gap distances (up to 1/2-inch) between the wrap and the sensor. The wrap and sensor system forgives slight misalignment of the sensor, machinery vibration, dirty, wet or greasy environments, and shaft end-play.

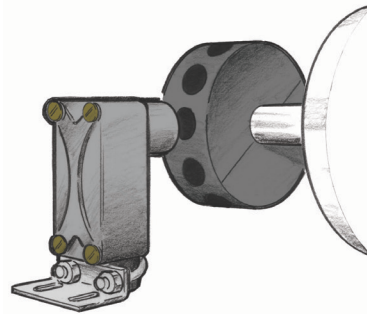
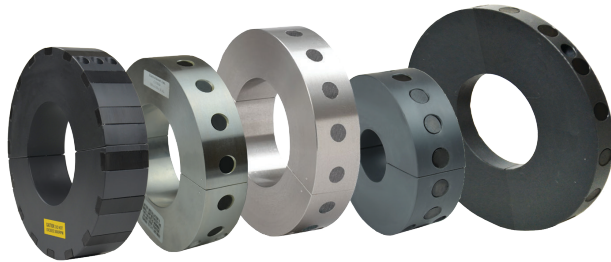

DRK & QDRK Digital Ring Kits include a mounting ring, hardware, a magnet wheel, and a sensor. They provide digital pulse feedback from motors with NEMA C face end bells, can generate pulses down to zero speed, and transmit without amplification up to 1,500 feet. This is an ideal pulse generator for speed monitoring, motor control, counting, process control, cut-to-length, and ratio/draw controlling applications.

DRK

The DRK Series Ring Kits can be quickly and easily installed on NEMA C face motors or between a motor and gear box. Each kit features a non-contacting digital pulse generator system.

QDRK

The QDRK Quadrature Ring Kit provides a 60-pulse per revolution quadrature signal, for use with electronic control equipment requiring rotational-direction information. Two signals, 90° out-of-phase, are produced by the sensor. When the leading edge of signal A precedes the leading edge of signal B, shaft rotation is forward. When the opposite is true, the monitored shaft is rotating in reverse.

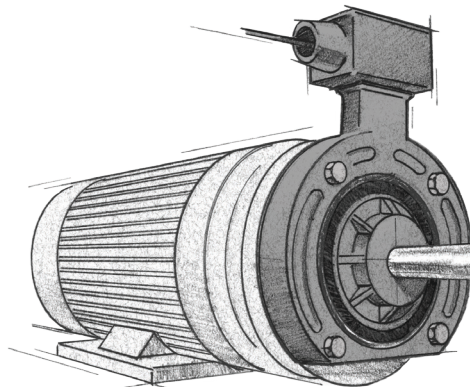

Rotary Shaft Encoders convert shaft rotation into square wave output pulses. They provide an accurate means of transmitting actual speed information for detecting rate, position, or direction of rotation. The shaft encoder produces an output signal by rotating a disc with clear and opaque segments between a light emitting diode and a photo-transistor sensor. The output signal from the encoder is then converted into a square wave signal by an internal squaring circuit. The number of output pulses per shaft revolution is determined by the number of clear and opaque segments on the disc. Quadrature (bi-directional) models have a second LED and sensor positioned 90-degrees apart to produce two square wave signals.

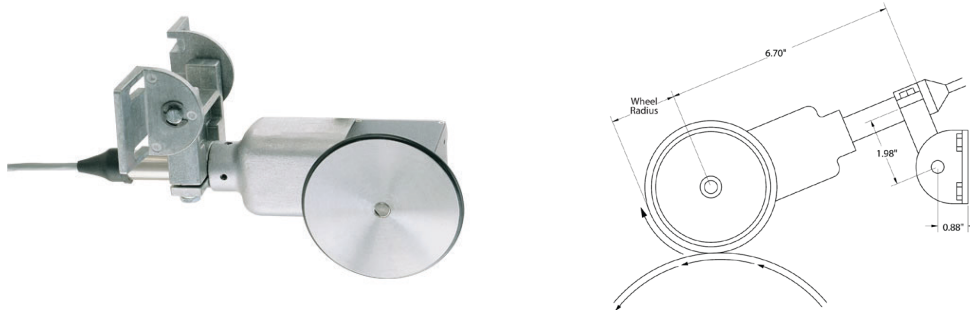
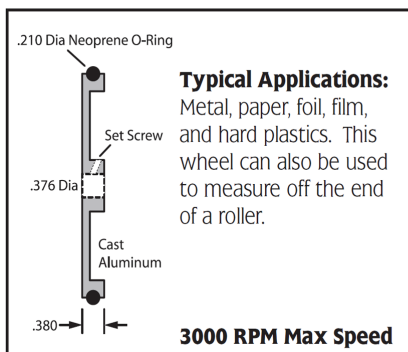

Traction Wheel: The traction wheel rides directly on the material being monitored. The wheel is connected to a rotary shaft encoder, which is supported by the mounting bracket. The encoder then generates a digital pulse frequency based on the number of pulses per revolution and the speed of the traction wheel. This digital signal is sent via the mating connector to a counter, ratemeter or other control equipment.

.210 Dia Neoprene O-Ring
Set Screw
.376 Dia
Cast Aluminum
.380

Typical Applications:
Metal, paper, foil, film, and hard plastics. This wheel can also be used to measure off the end of a roller.

3000 RPM Max Speed

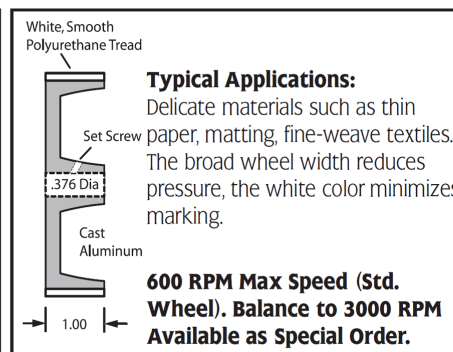

White, Smooth Polyurethane Tread
Set Screw
.376 Dia
Cast Aluminum
1.00

Typical Applications:
Delicate materials such as thin paper, matting, fine-weave textiles. The broad wheel width reduces pressure, the white color minimizes marking.

600 RPM Max Speed (Std. Wheel). Balance to 3000 RPM Available as Special Order.

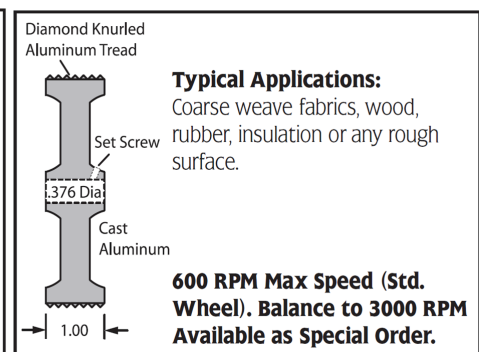

Diamond Knurled Aluminum Tread
Set Screw
.376 Dia
Cast Aluminum
1.00

Typical Applications:
Coarse weave fabrics, wood, rubber, insulation or any rough surface.

600 RPM Max Speed (Std. Wheel). Balance to 3000 RPM Available as Special Order.