

Key Features

- For Precise Master/Follower Control of AC or DC Variable Speed Drives
- 0.02% speed regulation.
- Security Lockout.
- Diagnostics for easy troubleshooting.
- Isolated speed reference signal.
- Optional analog feedback and set point.
- Two optional relay outputs.



Description

The Electro-Sensors Model MS320 Closed Loop Motor Speed Controller provides precise regulation of motor speed by controlling the speed reference signal to the variable speed drive. The MS320 monitors a feedback pulse sensor mounted on the motor, or on a downstream shaft, and compensates for any variations between the actual operating speed set point and the desired speed by automatically fine tuning the speed reference signal. The MS320 display can be scaled into meaningful units: RPM, GPM, FPM — for operator ease in monitoring and setting the desired speed. In the Master Mode, the MS320 ramps the motor to the selected set point at the programmed acceleration rate. Every 20 milliseconds the MS320 compares the set point with the digital or analog feedback signal. The control algorithm adjusts the speed reference signal to reduce the error to zero. In the follower Mode, the MS320 controls the follower motor speed based on a digital or analog lead signal. The follower motor runs at a user selectable ratio based on the lead input signal. The digital or analog feedback signal from the follower is used as a reference to confirm that it is running at the correct ratio, and that any speed error is driven to zero. Diagnostic test procedures are provided for easy troubleshooting of all input, output functions as well as keypad and display operation. A programmable security code and keypad lockout allow the user to protect selectable program variables and front panel functions from unwanted changes during operations.

There are three AC Inputs, one dedicated for Run/Stop, and two programmable for the following:

- Fast Stop
- Scroll Set-Point Up
- Jog
- Scroll Set-Point Down
- Closed/Open Loop
- Set-Point 1/Set-Point 2
- Master/Follower

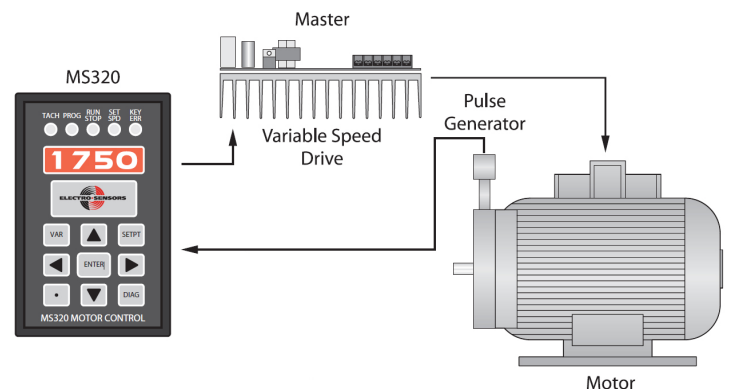

Typical Applications

- Packaging Machinery
- Centercore and Surface Winders
- Winding Machinery
- Ovens and Fans
- Pumps
- Extruders
- Printing Presses
- Replacement for some MS196 Units

Optional Expansion Board

Terminal Connections

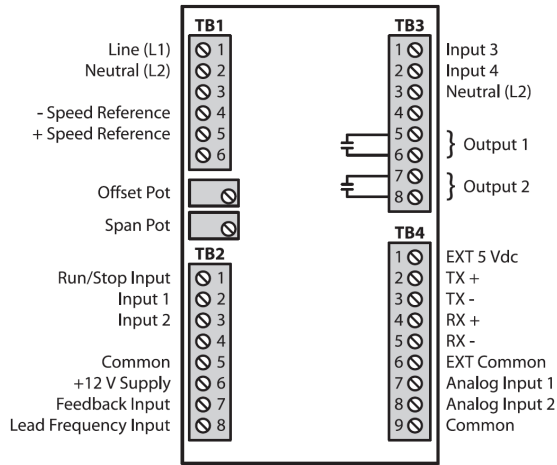

The optional expansion board provides the user with two additional inputs programmable for the same functions as the two standard inputs. Two SPST relay outputs are provided and programmable for the following: High Alarm, Low Alarm, Deviation Alarm, Zero Speed, Drive Enable and Ramp Complete. Two analog inputs (4-20 mA or 0-10 Vdc) are provided and programmable for the following: Feedback Frequency, Lead Frequency, Master Setpoint, Follower Ratio, Setpoint/Ratio Trim, Setpoint/Ratio Inverse Trim and Wind/Unwind with Core Calculation. The MS320 is ideal for Packaging Machinery, Centercore and Surface Winders, Wire and Cable Machinery, Feed to-Stop Systems, Cut Off Machines, Traverse Winding, Ovens and Fans, Pumps, Blenders and Feeders, Overhead/ Floor Conveyors and Extruders.

Ordering

Model Description	Part Number
MS320 0-10 115 VAC	800-070701
MS320 0-10 115 VAC W/Option	800-070705
MS320 4-20 mA 115 VAC	800-070703
MS320 4-20 mA 115 VAC W/Option	800-070707
MS320 0-10 230 VAC	800-070702
MS320 0-10 230 VAC W/Option	800-070706
MS320 0-10 10-30 VDC	800-070709
MS320 0-10 10-30 VDC W/Option	800-070711
MS320 4-20mA 230 VAC	800-070704
MS320 4-20mA 230 VAC W/Option	800-070708

MS320 Specifications

Input Power	
Voltage	115 Vac Standard, 230 Vac Optional 50 - 60 Hz, 6W, 10 - 30 Vdc Optional
Fuse	External Fuse required, 1/16 slo-blo recommended for 115 Vac and 1/32 A for 230 Vac, 2 Amp 10 - 30 Vdc
Sensor Supply	12 Vdc unreg., 100 mA max.
Sensor Input	Square, Triangle, Sine(Switch Selectable)
NPN Open Collector	2200Ω Pull Up, 2.5V Trigger Level
PNP Open Collector	2200Ω Pull down, 2.5V Trigger Level
Logic Level	2.5V Trigger Level
Magnetic Pickup	150 mV peak to peak min signal, 50 mV Trigger Level
Maximum Frequency	4000 Hz - Lead & Feedback Pulses
Enclosure	ABS Plastic
Keypad	Polycarbonate Tactile Switch Pad
Operating Temperature	0°C to +50°C, +32°F to 122°F
Humidity	0-90% Non-Condensing
Operation	
Accuracy	0.02% Master and Follower Mode
Response Time	20 msec
Modes of Operation	Master/Follower
Presets	2 Master, 2 Follower, 1 Jog
Display	4 Digit 0.3" 7-Segment Displays, 5 Status LEDs
External Control I/O	
Standard Inputs	3 AC Switch Inputs - 1 fixed (Run/Stop) 2 Programmable
Optional Programmable Inputs	2 Additional AC inputs, 2 Analog Inputs, 0-10 Vdc or 4-20 mA
Optional Relay Outputs	2 Programmable, Rated 250 Vac 5A, 30 Vdc 5A, Resistive Load

Specifications subject to change without notice.

Customization

If one of our standard products does not meet your specifications, please call one of our applications specialists. Many of our products can be customized to fit specific needs.

Additional Information

Please call Electro-Sensors for more information.