

AP1000 Digital Tachometer

Principle of Operation

A digital signal is transmitted to the AP1000. This signal has a frequency proportional to the rotational speed of the monitored shaft. The AP1000 translates this signal into RPM or any programmed user unit, such as HZ, FPM, GPM, or TIP (Time In Process). It displays this on the front panel LEDs. The AP1000 accepts a wide variety of signal types. The most common type is NPN open collector using an ESI Disc/Wrap and Hall Effect sensor.

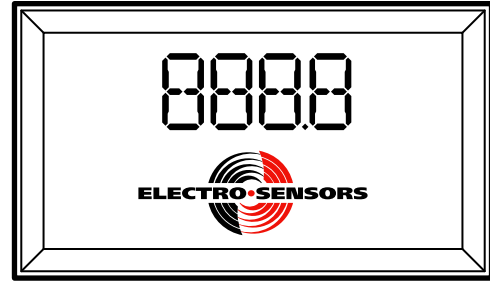

ESI Pulser Disc

The end of the shaft to be monitored must be center drilled to a depth of 1/2-inch with a No. 21 drill and tapped for 10-32UNF. After applying Loctite or a similar adhesive on the threads to keep the pulser disc tight, the pulser disc should be attached, decal side out, with the supplied 10-32UNF machine screw and lock washer.

ESI Pulser Wrap

Pulser Wraps are custom manufactured to fit the shaft they will be mounted on. When the wrap is shipped, Allen-head cap screws hold the two halves of the wrap together. These screws must be removed so that the wrap is in two halves. Place the halves around the shaft, reinsert the screws and torque them to 5 foot-pounds.

ESI Sensor Installation

The standard ESI sensor is supplied with a mounting bracket and two jam nuts. The explosion-proof sensor is supplied with a slotted mounting bracket. Sensors should be installed so the centerline of the magnets pass in front of the center of the sensor as the disc or wrap rotates. When using the pulser disc, the center of the magnetized area of the disc, shown as Dimension B in figures 1 and 3, is 1-3/4 inches from the center hole of the disc. Standard Sensor and Disc (Figure 1) The desirable gap distance between the sensor and the disc or wrap, Dimension A in the diagrams, is 1/4-inch \pm 1/8 inch. To achieve the proper gap distance, adjust the jam nuts holding the standard sensor in the mounting bracket, or adjust the position of the explosion-proof sensor using the slots on its mounting bracket.

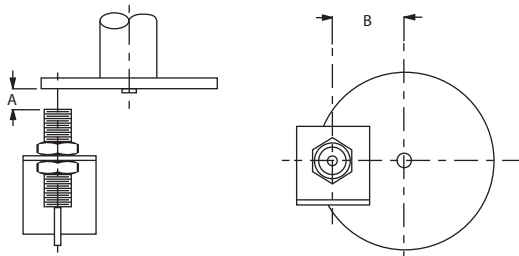

Figure 1: Standard 906 Sensor Pulser Disc

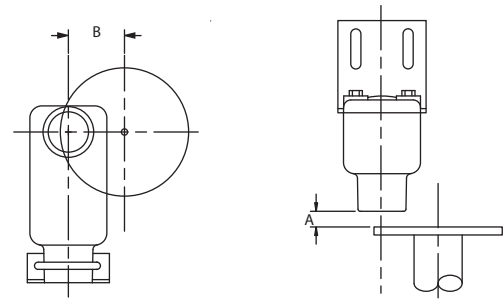

Figure 3: Explosionproof Sensor and Disc

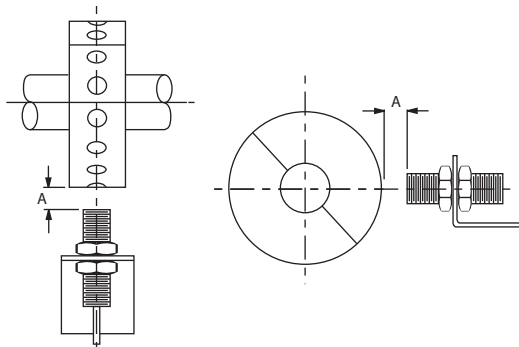

Figure 2: Standard 906 Sensor Pulser Wrap

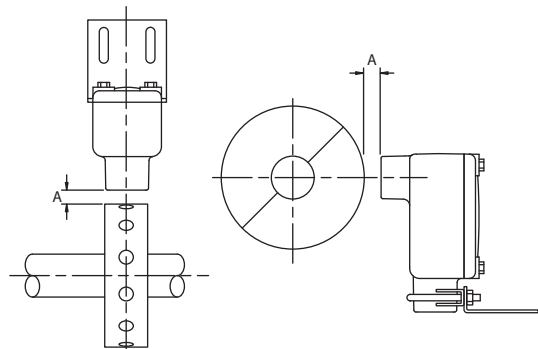

Figure 4: Explosionproof Sensor and Wrap

Meter Installation

Figure 5 shows the cutout for installation of the AP1000 meter in a panel. Four #4-40 flathead screws are provided to secure the meter to the panel. The front bezel of the AP1000 is removable allowing access to the screw holes. To remove the bezel, gently pry the frame upward while pulling it off.

Cutout for Panel Mounting

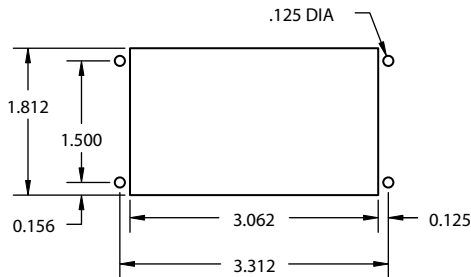

Figure 5: Panel Cutout Template

5 Position Switch (ON Activates Position)

1. Pull Up (NPN) Sensor (ESI standard type)
2. Pull Down (PNP) Sensor
3. Extra Filtering (2-Wire Magnetic Pickup)
4. Mag. Level (2-Wire Magnetic Pickup)
5. Calibration Lock

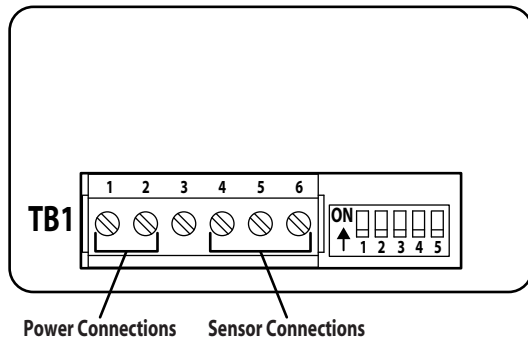

Figure 6: Wiring Connection diagram

Input Power

Input Power Connections are made on terminal strip TB1 (See figure 6.). Refer to the table below for the proper connections.

Connection	90-265 VAC	10-30 VDC Option
TB1-1	L1 (Line)	(+)
TB1-2	L2 (Neutral)	(-)

Sensor Connections

Sensor connections are made on terminal strip TB1 (see figure 6.). Refer to the table below for the proper connections.

Connection	Sensor 906 / 907 Type NPN	ESI Prox Type NPN	All other ESI Type NPN
TB1-4 Supply	Red	Brown	Red
TB1-5 Ground	Clear/Shield	Blue	Black/Shield
TB1-6 Signal	Black	Black	Clear

Variable Summary for OP 1(Rate)

- Variable 1: Maximum Frequency Input
 - (Default = 240.0)
 - Range: 000.1 – 9999 HZ
- Variable 2: User Units at Max Frequency Input
 - (Default = 1800)
 - Range: 000.1 - 9999
- Variable 3: Display Update Rate
 - (Default = 0.5 sec)
 - Range .5 to 8.5 sec

Calibration Limitations

The normal recommended calibration for the AP1000 is to use the maximum values possible to obtain the most accurate display. The AP1000 has an intentional range limitation, to prevent excessive zeroing time. It will only display 1 / 250 of the User Units programmed into Pr2. For some users this can be annoying, but the user can overcome this by scaling the display with no loss of accuracy. Example: user wants 0-3000 RPM @ 8 PPR. The calibration for this would be Pr1 = 0400 and Pr2 = 3000. This would result in a minimum display of 12 RPM. If this was unacceptable the customer could lower both Pr1 and Pr2 by the same factor. For the above example we will divide by 8. $400 / 8 = 0050$. For Pr2 $3000 / 8 = 375$. This would result in a minimum speed display of 2 without any loss of accuracy. The AP1000 will read beyond the User Units programmed so there will be no loss of top end, the unit would still read up to the desired 3000 RPM.

Resetting the AP1000 to defaults

Turn the power off, and depress the arrow keys. Reapply power while keeping the two arrow keys pressed. The software version will appear on the display (i.e. 02.00) then the unit will display “RESE” followed by “OP 1”. The arrow keys may now be released. The AP1000 will continue with normal operation applying the default values to calibrate the display. The default settings will allow you to display RPM without a decimal point from 0-9999. You don’t need to change any variables using our sensor and disc/wrap to display RPM.

Calibrating the Display

Note: The default settings are for RPMs with no decimal point using the standard ESI sensor and standard ESI disc.

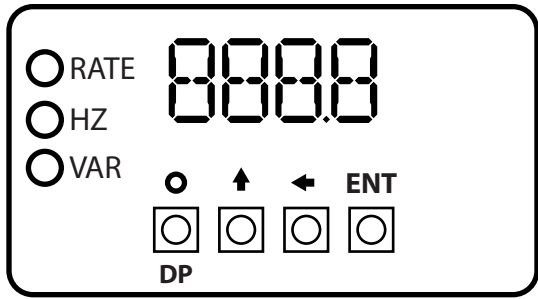

Figure 7: Front Panel (With Bezel Removed)

The AP1000 Tachometer is factory calibrated to display the shaft speed in RPM, using a pulser disc or wrap, and a Hall Effect sensor. The AP1000 meter can be calibrated to display speed in units other than RPM. To calibrate for other units remove the bezel by gently prying the frame of the bezel up while pulling it off. The four-button keypad is used for calibrating the display, (see figure 7.) The first two variables are needed for linear display in user units; the third is for customizing the display update time. To enter the change variable mode, have the AP1000 powered up and DIP switch position 5 = OFF. Pressing the ENT key once will illuminate the VAR LED and Pr1 will be displayed for 1 second. After 1 second, the value of Variable 1 (Max Hertz) is displayed. The far right digit of Variable 1 will flash on and off, indicating this digit has the focus and can be changed by using the up arrow key. To change another digit in Variable 1, use the left arrow key to change the focus to the next digit. The decimal point key can be used to add or remove a decimal point. When Variable 1 contains the correct value, press the ENT key once. Pressing the ENT key will store the value of Variable 1 in non-volatile memory and will display Pr2 for one second. After one second the value of Variable 2 will be displayed Variable 2 represents the user units for the input frequency programmed into Variable 1. For example, if 1800 Hz is programmed into Variable 1 and this corresponds to 1000 bottles/minute, program 1000 into Variable 2. Then, when an 1800 Hz input signal is fed into the AP1000, it will display 1000. If a 900 Hz input signal is presented, the AP1000 will display 500. After programming variable 2 with the desired user units, press the ENT key once to store Variable 2. Pr3 will be displayed for 1 second, and then the value of Variable 3 will be displayed. Variable 3 represents the time between display updates. Increasing the time between the updates will average more information and reduce the ‘bouncing’ effect on the display for unstable input signals. Press the ENT key to store Variable 3. The display will return to displaying either RATE or Hz depending on which was displayed prior to programming the Variables.

Displays

Rate

At power up, the AP1000 will display RATE in user units. The equation used to generate the display is the following:
 Display = User Units (Variable 2) x Input Signal Frequency Max frequency (Variable 1) The decimal point will always be placed

in the same location as it is programmed in Variable 2.

$$\text{Hz} = \frac{\text{RPM} \times \text{PPR}}{60}$$

Hz

If the up arrow is pressed while RATE is displayed, the display will change to Hz. This display is simply the input signal frequency detected on terminal TB1-6. The decimal point will always be placed in the same location as it is programmed in Variable 1. To toggle back to RATE display, press the up arrow key again.

TIP (Time In Process)

All AP1000 tachometers contain the necessary code to function as a TIP display, alternate literature is available at www.electro-sensors.com

Front Panel Lockout

To protect the values programmed into the variables, set DIP switch position 5 to ON.

Troubleshooting

Problem Cause	Possible Solution
No Readout	Check sensor wiring
	Sensor type incorrect. Standard is ESI NPN
	Operating below cutoff. (see calibration limitation)
Readout is Jumping	Sensor too far from Disc/Wrap
	Missing magnets on the Disc/Wrap that has discrete magnets
Unit is dead	Verify correct power is being input at TB1-1 and TB2
	Disconnect sensor, to verify that it is not shorting
Unit will not program	Switch number 5 is not turned off
Rate display is desired but the AP1000 doing the opposite.	Power down and then back up and verify that “OP1” displays. If not reset the tachometer and reprogram.

AP1000 speed switch specifications

Input Power	Parameters
Standard	90-265 VAC 50/60 Hz
Optional	10-30 VDC
Wattage	AC: 1 VA DC: 1.5 W

Input Signal	Parameters
Type	NPN, PNP, Magnetic Pickup, Logic
Impedance	3300 ohms
Trigger Level	2.5VDC or 50mVDC
Frequency	0.01 – 9999 Hz

Sensor Supply	Parameters
Transducer Supply Maximum	AC: 13.5VDC, 50 mA DC: 8-24VDC (based on input VDC)

Physical/Environment	Parameters
Housing and Cover	Noryl 255
Enclosure Dimensions	See Figure 6
Operating Temperature	0°C to +70°C*
Storage Temperature	-65°C to +70°C*

AP1000 Dimensions

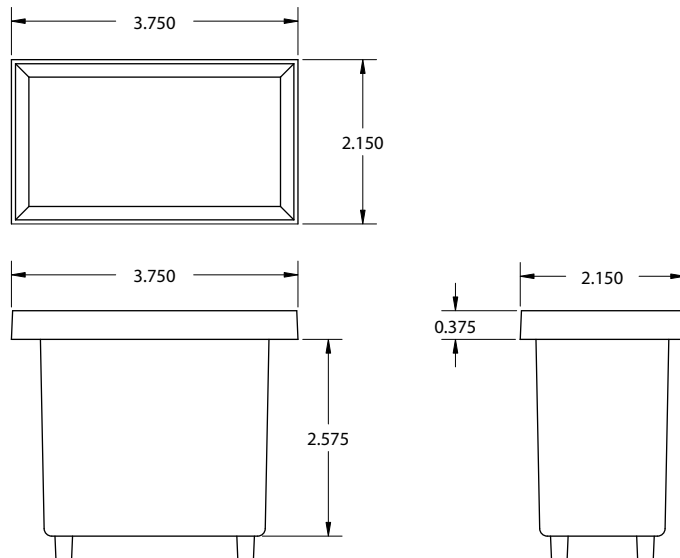

Pulsar Disc Dimensions

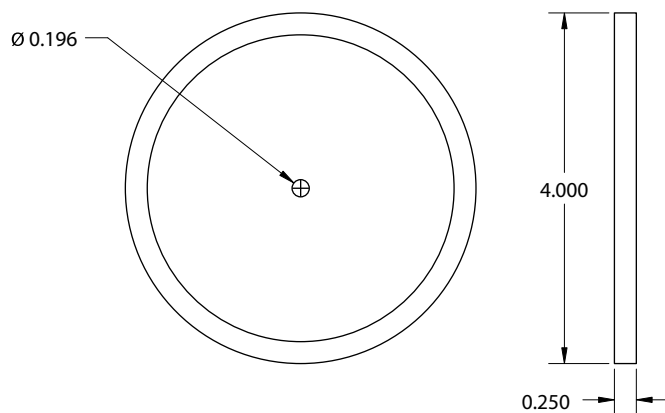

Pulsar Disc	Parameters
Material	Nylon 12 Std, Aluminum Opt.
Dimensions	4-inch diameter x 1/4-inch thick
Operating Temperature	0°C to +60°C*
Maximum Speed	Consult factory

Pulsar Wrap	Parameters
Material	Consult factory or visit our website
Operating Temperature	0°C to +60°C*
Maximum Speed and Temperature	Consult factory

Standard Sensor	Parameters
Material Sensor Body	Aluminum 3/4 - 16UNF thread
Material Mount Bracket	Plate steel
Output Types	NPN open collector current sinking 20 mA max
Signal Cable	3-conductor shielded, 10 feet length
Operating Temperature	0°C to + 60°C*
Air Gap	1/4 inch +/- 1/8 inch

Specifications are subject to change without notice.

***For higher or lower temperature ranges, consult factory.**

906 Sensor Dimensions

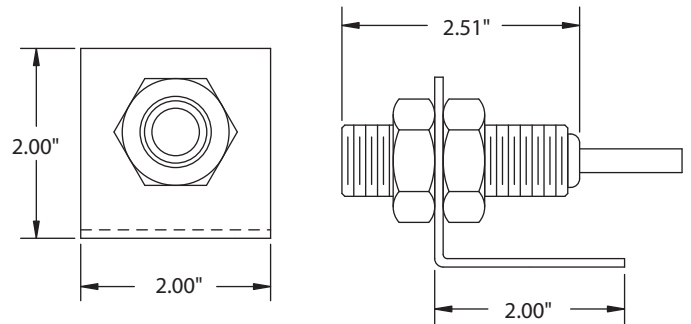

Alum XP Sensor Dimensions

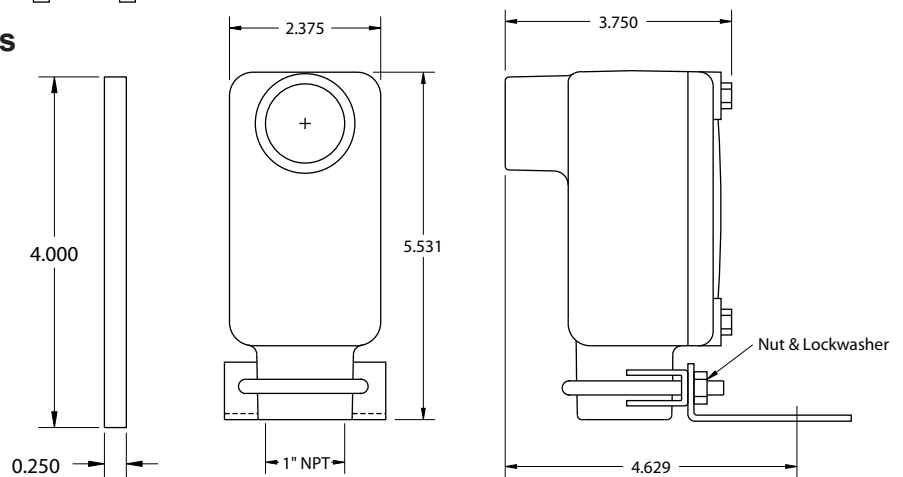

Free Catalog and Application Assistance

1.800.328.6170

Website: www.electro-sensors.com

990-001900 Revision D