

BT348

Low cost Operator Terminal with Serial Interface



- Suitable for simple remote operation with all motrona controllers and units from other manufacturers using the same serial protocol (Drivecom, Lecom)
- Low-cost solution for readout and remote setting of single parameters on control units and drives
- Also suitable for remote display of actual measuring values via serial link
- Easy operation and set up by means of three front keys

Operating Instructions



Safety Instructions

- This manual is an essential part of the unit and contains important hints about function, correct handling and commissioning. Non-observance can result in damage to the unit or the machine or even in injury to persons using the equipment!
- The unit must only be installed, connected and activated by a qualified electrician
- It is a must to observe all general and also all country-specific and application-specific safety standards
- When this unit is used with applications where failure or maloperation could cause damage to a machine or hazard to the operating staff, it is indispensable to meet effective precautions in order to avoid such consequences
- Regarding installation, wiring, environmental conditions, screening of cables and earthing, you must follow the general standards of industrial automation industry
- - Errors and omissions excepted –

Version:	Description
BT34801a/KK/HK/MAR.05	Original
BT34801b/KK/HK/AUG.05	Small corrections p. 4 and 8
BT34802a/KK/HK/SEP.08	LCD display with decimal point

Table of Contents

1. Introduction.....	4
2. Terminal Assignments	5
2.1. Power supply	5
2.2. Serial interfaces	5
3. How to Operate the Unit.....	6
3.1. Basic setup of the unit	6
3.2. Basic setup of the unit	8
3.3. Reset the setup registers to „Default“	9
3.4. Releasing a Self Test CYCLE	9
4. Keypad Interlock	11
5. Appendix.....	12
5.1. Important hints for operation	12
5.2. Error messages	12
5.3. Representation of register codes	12
5.4. The star key	13
6. Dimensions and Specifications.....	14

1. Introduction

BT 348 represents a small and low cost operator terminal, suitable for serial remote control of motrona units, and of controllers or drives of other manufacturers accepting the same serial communication protocol.

The unit provides a simple and easy possibility for cyclic readout of a specific parameter, and allows to change and edit it by means of the two front keys.

The same communication protocol is frequently used with other standard units like drives or automation products. All communication details are described in our special "SERPRO" manual, available from the download section of our homepage.

BT348 provides 3 simple basic functions:

- **Display mode**
Cyclic readout of a parameter from the specified target location and display of the parameter value. The cycle time is register settable
- **Edit mode**
The value shown in the display can be modified by use of the front keys, and then transmitted and stored to the target unit as a new setting.
- **Configuration mode**
Used for setup of the BT348 and for basic configuration of the unit

2. Terminal Assignments

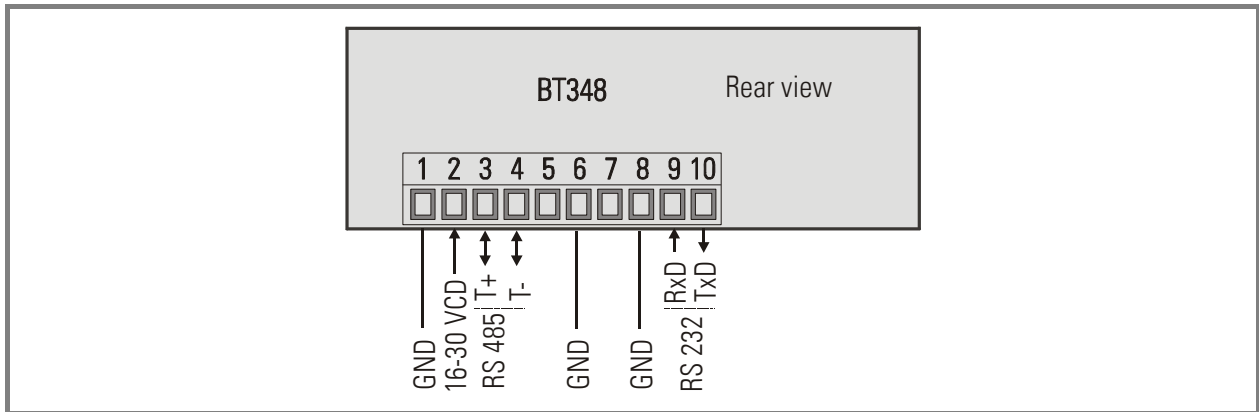

2.1. Power supply

The unit accepts a DC supply from 16V to 30 volts which must be applied to terminals 1 and 2. The consumption depends on the level of the supply voltage (typical 30 - 40 mA at 24 V).

2.2. Serial interfaces

The unit provides a serial RS232 interface and a RS485 interface. RS232 transmission is limited to cable length of approx. 10 meters. For longer distances between terminal and target unit please use the RS485 interface.



Please note:

You must never connect both serial interfaces at the same time!

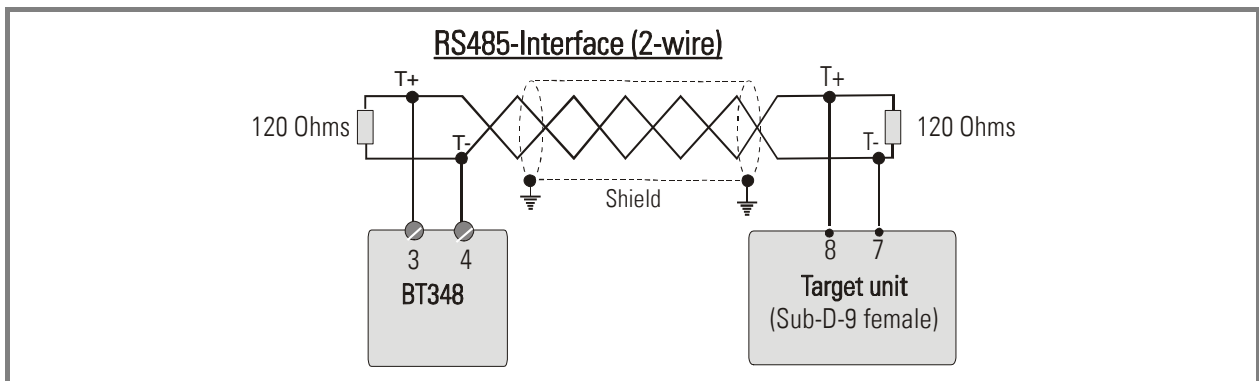
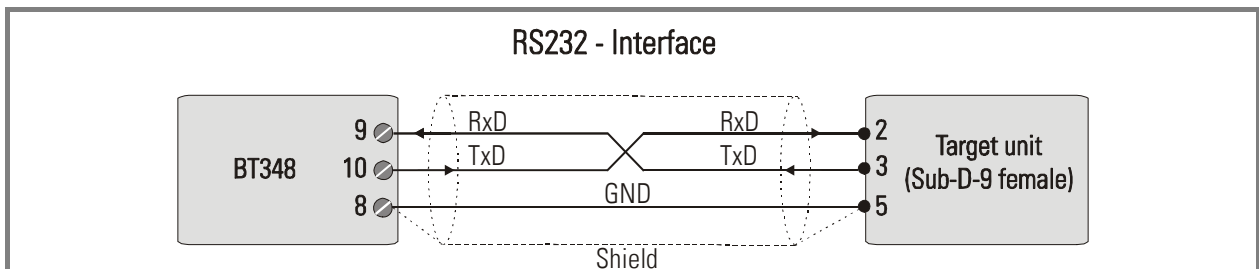

3. How to Operate the Unit

The subsequent steps require the keypad to be unlocked. When the keypad is latched, all operations of the keys will be responded by display of



See section 4. (Keypad Interlock)



3.1. Basic setup of the unit

The basic setup procedure, in general, is only necessary upon the first commissioning of the operator unit. The following registers need to be set:

Menu Step	Description
CodE	<p>Code Serial register code of the parameter in the target unit which should be displayed or modified (see also appendix) Setting range: 0 ... 199 Default value: 101 (= ":1")</p>
rt, rE	<p>Refresh Time Cycle time for readout of the selected parameter. Setting range: 0 ... 9999 msec Default value: 100 msec Settings < 100 are taken as 100 msec</p>
S-Unit	<p>Serial Unit Number Unit address of the target device connected to the terminal Setting range: 11 ... 99 Default value: 11</p>
CtYPE	<p>Code-Type Selects standard or extended protocol "StAnd" = Standard protocol "EtEnd" = Extended protocol Setting range: StAnd, EtEnd Default value: StAnd See description of protocols "SERPRO"</p>
S-EEP	<p>Store EEPROM Selects if transmitted parameters should be stored in the EEPROM of the target unit or not YES = Storage in EEPROM No = no storage in EEPROM (setting valid until next power-down only) Setting range: YES, no Default value: no</p>

Menu Step	Description
LATCH	<p>Keypad interlock (Latch) Locks or unlocks the front keys YES = Keys locked no = Keys unlocked Setting range: YES, no Default value: no</p>
S-bAUD	<p>Serial Baud Rate Rate of data transmission Setting range: 9600, 4800, 2400, 1200, 600, 19200, 38400 Default value: 9600</p>
S-Form	<p>Serial Data Format Format of data bits (data-parity-stop bits) Setting range: 7-E-1, 7-E-2, 7-O-1, 7-O-2, 7-no-1, 7-no-2, 8-E-1, 8-O-1, 8-O-2, 8-no-1, 8-no-2 Default value: 7-E-1</p>
br. Ght	<p>Brightness Brightness of LED display as percent of maximum brightness Setting range: 100, 80, 60, 40, 20% Default value: 100%</p>
dPo int	<p>Decimal Point Sets the decimal point of the display.</p> <p>000000 No decimal point 00000.0 one decimal position ----> 00.0000 four decimal positions</p> <p>Default value: 000000</p>

To access the configuration menu, press **both front keys at a time** and keep them down for approx. 3 seconds. The subsequent example shows how to change register „Refresh Time“ from 100 to 500 and then store the new setting

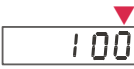
 = short actuation
 = long actuation (>2 sec)
 Blinking decade

Menu Step	Selection	Description
	1239	Normal operation, display of the parameter according to Code setting
	→ CODE	Start of the configuration menu
	→ rti r n E	Scroll forward to next register
	→ 100	Select register „Refresh-Time. Display shows actual setting, LSD blinking (cursor function)
	→ 100	Shift cursor to left
	→ 100	Shift cursor to left
	→ 500	Increment digit (4 x)
	→ rti r n E	Accept new setting
	→ 1239	Store new setting to EEPROM and return to normal display

3.2. Basic setup of the unit

The unit continuously displays the value of the register of the target unit specified under "CODE". It can be modified at any time.

To change a parameter and transmit it to the target unit, please press the left side key for about 3 seconds. The subsequent example explains how to change the parameter from 1000 to 1500:

Menu Step	Selection	Description
	1000	Normal operation, display of the parameter according to Code setting
	→ 001000	Start of the editing procedure, last digit blinking (cursor)
	→ 001000	Scroll cursor two positions to the left
	→ 001500	Increment highlighted digit)
	→ 1500	Store new setting and transmit to target unit *)
	1500	Edit end

*) If you omit this step, the display will start blinking and after 7 seconds the unit will return to normal operation without transmission of the new setting.

When in the basic set up register S-EEP has been set, the new value will automatically be stored in the EEPROM of the target unit. Otherwise the new setting will be active until to next power-down of the target unit only.

The scrolling range of the most significant digit includes the figures 0 – 9 and the symbols “-” and “-1” for settings with a negative sign.

3.3. Reset the setup registers to „Default”

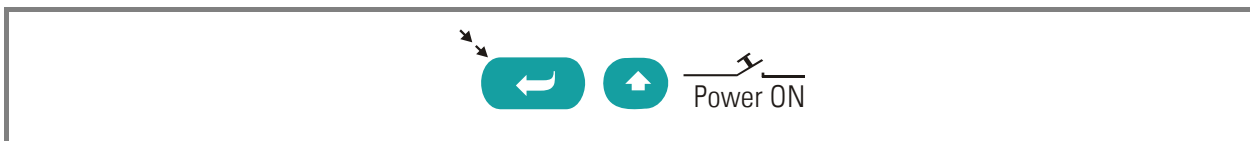

When you keep down the left key while you power the unit up, all settings will be reset to the default values as shown in section 3.1

The default settings match the settings of motrona controllers upon delivery, therefore an immediate communication should be possible (exception: MC700 and MC720 controllers need the Code type “Extend” instead of “Standard”).

3.4. Releasing a Self Test CYCLE

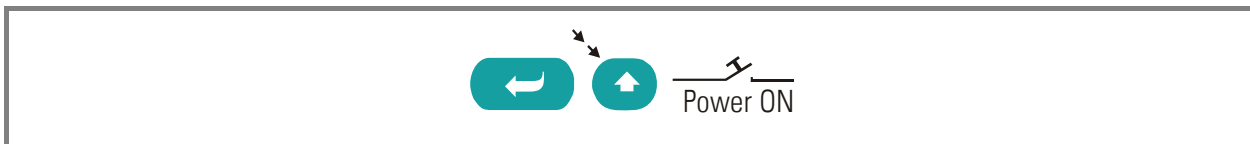

To release a self-test cycle, please keep down the right side key while you power the unit on.

The subsequent table explains the various tests executed by the unit.

When the cycle arrives at the key tests (“TAS A” and “TAS B”) the unit waits for a short actuation of the appropriate key before the testing cycle continues.

#	Test	Description	Test result	LCD display
0	Start of test cycle			"SELF"
1	Internal voltage test	Check of the internal 5,0 volts	ok	" 5U i0"
			not ok	" _5U_ "
2	Internal check sums	Checksum test of EEPROM 1	ok	"EP1 i0"
			not ok	"__EP1_ *")
3		Checksum test of EEPROM 2	ok	"EP2 i0"
			not ok	"__EP2_ "
4	Display test	Check of the segments of the LED display		Every segment separately
5	Front key tests	Check key A (left)		"TAS A"
			ok	"A i0"
			not ok	"TAS A"
		Check key B (middle)		"TAS B"
			ok	"B i0"
			not ok	"TAS B"
		Check key C (right)		"TAS C"
			ok	"C i0"
			not ok	"TAS C"
6	End of test	Unit returns to normal operation		"End"

*) When the checksum test fails, the display shows the calculated (wrong) checksum after approx. 4 seconds.

4. Keypad Interlock

The keypad interlock function serves to avoid unauthorized or unintended operations. When the keypad is locked (see section 3.1), every keypad action will be responded by display of



To suspend the locking, you must press the key sequence



within approx. 10 seconds. After this the keys operate normally.

As soon as no key has been touched for a time of 10 seconds, the unit automatically returns to normal operation and the keys are locked again.

5. Appendix

5.1. Important hints for operation

- The unit accepts numeric values inside the limits of -199999 and 999999. If the target unit transmits a value beyond these limits, the display will show the corresponding limit value and blink.
- The unit does not check if a parameter in the target unit is allowed for changes at all, nor if the value lies inside the permitted range. The operator himself must therefore be aware at any time what the result of his actual operation will be.
- When the target unit does not accept a transmitted value (e.g. because out of range etc.), the display will show an error message.

5.2. Error messages

In case of an error, the changes in an alternate sequence between normal and error display, according to the following table.

Err 01	Target unit does not accept the transmit value (out of range etc.)
Err 02	No serial connection to target unit (wrong cable or serial communication settings incorrect)
Err 04	Unknown register code in the target unit

5.3. Representation of register codes

For the register codes of your target unit please refer to the corresponding manual.

For all general details about codes and communication protocol, see our manual "SERPRO" which is also available for download from our homepage.

Target units operating with standard code* use also characters like colon, semicolon etc., which cannot be shown on a 7-segment LED display. Therefore, for these characters the BT348 unit uses a display system according to the table below.

Target units using the extended code always have a 4-position hexadecimal presentation, and the LED uses figures 0-9 and characters A, b, c, d, E, F for display

*) The majority of all motrona units at present use the standard code as shown below. Only motion controllers of the types MC700 and MC720 actually use extended register codes.

Serial Code	LED display	Serial Code	LED display	Serial Code	LED display	Serial Code	LED display
00	000	:8	108	<0	120	@0	160
01	001	:9	109
...	...	;0	110	<9	129	@9	169
98	098	;1	111	=0	130	A0	170
99	099	;2	112
:0	100	;3	113	=9	139	A9	179
:1	101	;4	114	>0	140	B0	180
:2	102	;5	115
:3	103	;6	116	>9	149	B9	189
:4	104	;7	117	?0	150	C0	190
:5	105	;8	118
:6	106	;9	119	?9	159	C9	199
:7	107						

5.4. The star key



This key is reserved for special functions and is not used with standard units.

6. Dimensions and Specifications

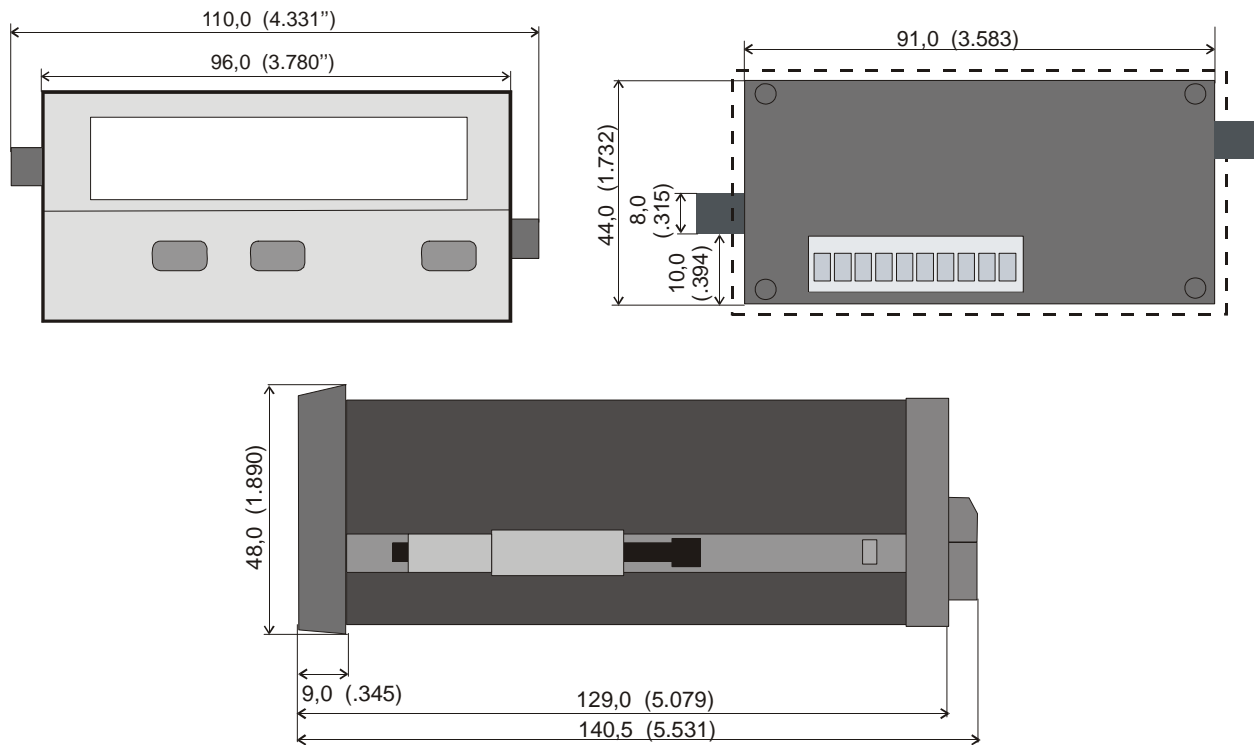

Panel Cut-Out: 91 x 44 mm (3.853 x 1.732")

Supply voltage DC	:	24V (16 – 35V)
Consumption	:	24V : approx. 35 mA
Ambient temperature	:	Operation: 0° - +45°C (32° - 113°F) Storage: -25° - +70°C (-13° - 158°F)
Housing	:	Norly UL94 – V-0
Display	:	6 Digit, LED, high- efficiency orange, 15mm
Interfaces	:	RS232, RS485 (2-wire)
Protection class	:	Front IP65, Rear IP20
Panel cut out	:	91 x 44mm
Terminals	:	10 x max. 1.5 mm ²
Conformity and Standards	:	EMC 89/336/EEC: EN 61000-6-3 EN 61000-6-2 LV73/23/EEC EN 61010-1