

Digital Speed Sensors

Models 906 Single-Channel & 906B Quadrature

Description

The 906 and 906B Digital Speed Sensors use Hall-effect technology to produce digital pulse signals for use with speed switches, tachometers, counters, signal conditioners, or as direct pulse input into programmable controllers. As a pulser disc or shaft wrap mounted on the monitored shaft rotates, the target magnets pass in front of the sensor. The sensor switches high and low as it is exposed to the alternating polarity of the magnets on the disc or wrap, which produces one pulse for every two magnets.

The 906 and 906B Sensors allow a gap distance up to 3/8" between the surface of the sensor and the target magnets. The gap flexibility makes the sensors tolerant of vibration, slight shaft run-out, and minor misalignment. The 906 and 906B Sensors are waterproof and suitable for most applications, including environments where dirt, dust, grease, or moisture are present.

The 906 and 906B Sensors can be mounted up to 1500 feet from the control unit, speed switch, tachometer, etc. They are powered by 5-24 VDC and provide an NPN Open Collector output. The 906 and 906B Sensors have a threaded aluminum body and are supplied with a mounting bracket.

Pulser Disc

The end of the shaft to be monitored must be center drilled to a depth of 1/2" with a No. 21 drill and tapped for 10-32 UNF. After applying Loctite® or a similar adhesive on the threads to keep the pulser disc tight, the pulser disc should be attached decal side out with the supplied 10-32 UNF machine screw and lock washer.

Pulser Wrap

Pulser Wraps are custom manufactured to fit the shaft they will be mounted on. When the wrap is shipped, four Allen-head cap screws hold the two halves of the wrap together. These screws must be removed so that the wrap is in two halves. Place the halves around the shaft, reinsert the screws and torque them to 5 foot-pounds.

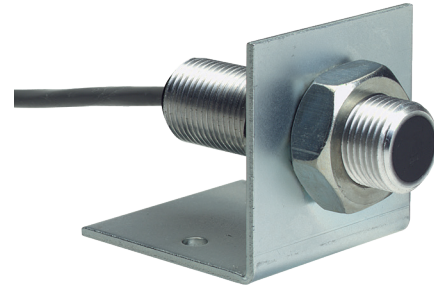

Electrical Connections

The 906 and 906B sensors are designed for use with devices that have an internal pull-up resistor. If the device receiving the signal from the sensor does not have a pull-up resistor, a resistor must be placed between the sensor supply voltage and the sensor signal output. Two pull-ups are required for 906B sensors.

Supply Voltage	Resistor Value	Resistor Wattage
5V - 11V	1K	1/4 Watt
12V - 15V	2.2K	1/4 Watt
16V - 24V	4.7K	1/4 Watt

906 Sensor

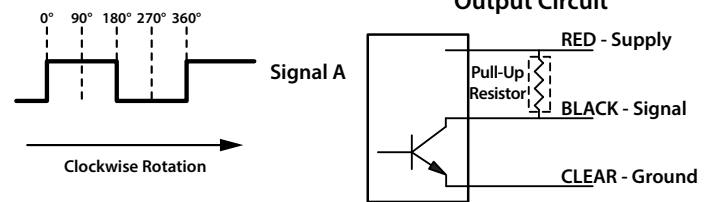

Note: Exercise caution when wiring the sensor. Damage will occur if the SIGNAL and SUPPLY wires are shorted.

Wiring Chart

Color	Connect To	Description
Shield	Circuit Ground	Transducer Shield
White or Clear	Circuit Ground	Transducer Ground
Red	Supply	Transducer supply Voltage
Black	Sensor A	Signal A
Green	Sensor B	Signal B (906B Only)

906B Sensor

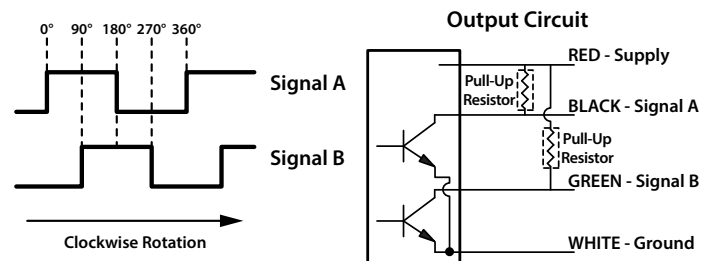

6111 Blue Circle Drive
 Minnetonka, MN 55343
 Phone: 952.930.0100
 Fax: 952.930.0130
 ISO 9001:2015 Certified



Free Catalog and Application Assistance
 1.800.328.6170
 Visit Us Online
www.electro-sensors.com
 990-001600 Revision E

Sensor Installation

The standard sensor is supplied with a mounting bracket and two jam nuts. Sensors should be installed so the center line of the magnets pass in front of the center of the sensor as the disc or wrap rotates. When using the pulser disc, the center of the magnetized area of the disc, shown as Dimension B in figures 1 and 3, is 1-3/4" ±1/8" from the center hole of the disc.

The recommended gap distance between the sensor and the disc or wrap, Dimension A in the diagrams, is 1/4" ±1/8" using 1/2" magnets. To achieve the proper gap distance, adjust the jam nuts holding the standard sensor in the mounting bracket.

Important: A label has been placed on the face of the 906B sensor. The sensor must be positioned so that the magnets pass down that line (the center line of the magnets and the line on the sensor must be parallel with each other). See illustration below.

Note: If your device reads in the wrong direction, reverse the sensor A and sensor B leads.

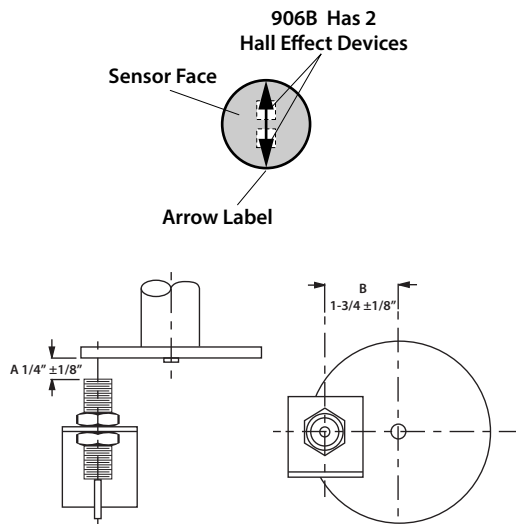

Figure 1: 906 or 906B with Pulser Disc

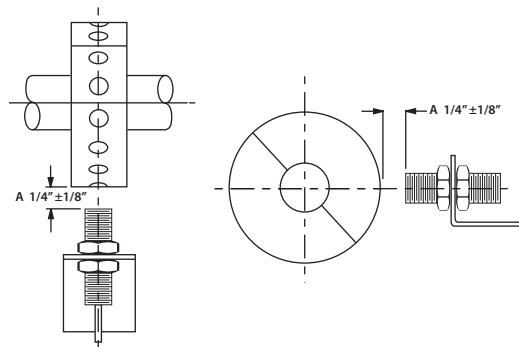



Figure 2: 906 or 906B with Pulser Wrap

906 & 906B Specifications

Supply 906	5-24 Vdc @ 10 mA
Supply 906B	5-24 Vdc @ 20 mA
Output Type	NPN Open Collector
Current sink	25 mA Max
Max Frequency	20 kHz
Temp Range	-40° C to +60° C*
Gap Distance	1/4" +/- 1/8" w 1/2" Magnets
Max Cable Length	1500 feet
Body Material	Aluminum
Cable	3-Conductor (standard), Shielded 4-Conductor (B version), Shielded
Mounting Bracket	Zinc Plated Steel, Included

906 & 906B Sensor		Control Number: 69003 Intrinsically Safe Apparatus and Associated Apparatus for use in Class I, II and III Div I Hazardous Classified Locations UL913 (1997) CAN/CSA-C22.2 No. 157-92
-------------------	--	--

* Higher temperature versions available, consult factory.

Part Dimensions

906 or 906B Sensor

