

MM-2.00 Mounting Magnet Installation Instructions

For use with the EZ-SCP Mounting Bracket

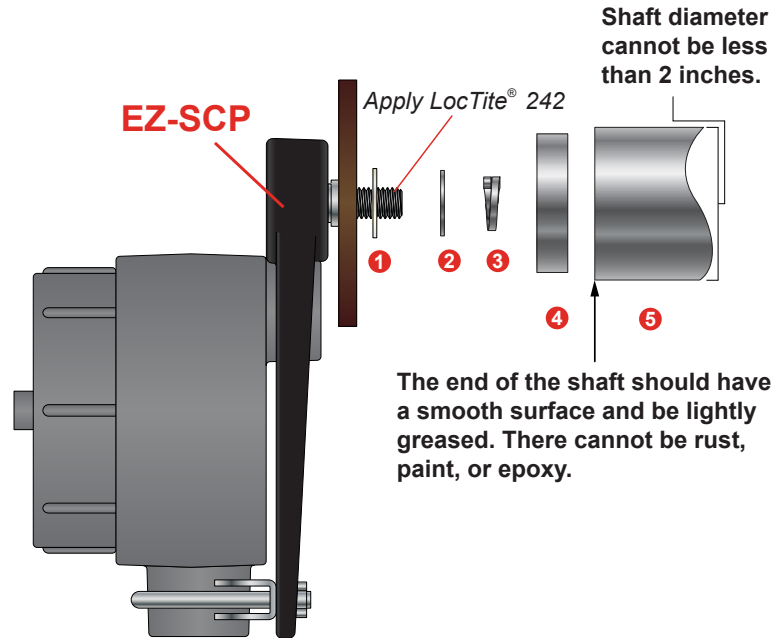

- | | |
|------------------------|---------------------------|
| 1 Nylon Holding Washer | 4 MM-2.00 Mounting Magnet |
| 2 1/2" Flat Washer | 5 Shaft End |
| 3 1/2" Lock Washer | |

Installation procedure:

- Put nylon washer and 1/2" flat washer and 1/2" lock washer onto shaft of EZ-SCP as shown above.
- Apply *LocTite*® 242 or equivalent to threads of shaft and inside MM-2.00 mounting magnet.
- Tighten MM-2.00 mounting magnet onto shaft of EZ-SCP using 3/8" hex wrench and adjustable jaws pliers or pipe wrench. Torque to 5 ft-lbs. Allow to cure for 2 hours before use.
- Lightly grease end of shaft with silicone grease to assist in centering mounting magnet.
- Remove protective metal disc and spacer from face of magnet.
- Carefully install unit onto center of the monitored shaft end. Magnet is very strong, avoid pinching fingers!
- Secure wiring and conduit.

Proper lock-out and tag-out procedures must be followed during the installation procedure. The shaft must be stopped during the entire installation process. The mounting magnet is very powerful. Keep all sensitive devices such as credit cards away from the magnet since they can be damaged. Do not allow hands, fingers, or tools to come between the magnet and any ferrous material, serious injury could result.