

IP 251

Universal Signal Converter

SSI —▶ parallel

RS232 —▶ parallel

SSI —▶ RS232



- Suitable for operation with sensors and encoders using SSI interface
- Converts SSI data as well as serial data to parallel data format
- Parallel output 25 bits (push-pull, short-circuit proof)
- RS232 interface for serial readout of the sensor data
- SSI: Master or Slave operation
- Linearization facilities by freely programmable input-output curves
- Additional facilities like bit-blanking, round-loop-operation etc.
- 18–30 volts DC power supply

Operating Instructions



Safety Instructions

- This manual is an essential part of the unit and contains important hints about function, correct handling and commissioning. Non-observance can result in damage to the unit or the machine or even in injury to persons using the equipment!
- The unit must only be installed, connected and activated by a qualified electrician
- It is a must to observe all general and also all country-specific and application-specific safety standards
- When this unit is used with applications where failure or maloperation could cause damage to a machine or hazard to the operating staff, it is indispensable to meet effective precautions in order to avoid such consequences
- Regarding installation, wiring, environmental conditions, screening of cables and earthing, you must follow the general standards of industrial automation industry
- - Errors and omissions excepted –

Version:	Description:
IP25101a/ HK/AF/ April 03	Original Version
IP25101b/ AF/HK/ Aug. 03	Correction DIL-switch position 7 ON/OFF "Parallel Mode" 3,4,5 and "Parallel Value" for direct serial access to the parallel output

Table of Contents

1. Introduction	4
1.1. Applicable encoders and sensors:	4
1.2. Remark about the encoder resolution:	4
2. Terminal Assignment	5
3. Connections	6
3.1. SSI encoder, Master operation	6
3.2. SSI encoder, Slave operation	6
3.3. Hold input	6
3.4. Parallel outputs	7
3.5. "Data stable" output	7
3.6. Serial interface	8
4. DIL Switch Settings	9
5. Extended Functions with PC Setup	10
5.1. Self Test	11
5.2. Output value	11
5.3. Hold key	11
6. Parameters	12
6.1. Scaling of serial readout data	12
6.2. Scaling of parallel output data.....	12
6.3. Ring counter, parameter "Round Loop":	14
6.4. More parameters:.....	16
7. Test Functions	21
8. Specifications and Dimensions	22
9. Parameter List, Default Settings	23

1. Introduction

IP251 represents a small and low-cost, but highly performing converter for industrial applications, where the information of a sensor or encoder with SSI interface needs to be converted to a parallel signal or a serial RS232 data format. Also it is possible to convert serial RS232 data to a parallel format.

The unit has been designed as a compact module with 12 screw terminals, a 9-position and a 25-position SUB-D connector (female). The housing is suitable for standard DIN rail mounting.

1.1. Applicable encoders and sensors:

Single-turn or multi-turn absolute encoders and all similar sensors using a standard SSI interface (6 to 25 bits of resolution with binary or Gray code). The unit can operate in either

- Master mode (clock signal generated by the IP251 unit), or in
- Slave mode (clock signal generated by a remote device)

1.2. Remark about the encoder resolution:

The unit provides settings for the standard resolutions of 13 bits, 21 bits and 25 bits. In general, for sensors with other resolutions you can use the next higher setting (i.e. set the unit to 21 bits with a sensor of 16 bits).

Depending on brand and specification of the encoder, in some cases it may be necessary to blank out the surplus bits by using the bit blanking function described later. In general however, the unit should work perfectly also without special bit blanking.

2. Terminal Assignment

The subsequent diagram shows the assignment of the screw terminals.

We recommend to connect the Minus wire of the power supply to earth potential.

GND terminals 4 and 6 are connected internally. Depending on input voltage and load of the auxiliary voltage output, the total power consumption of the unit is about 200 mA.

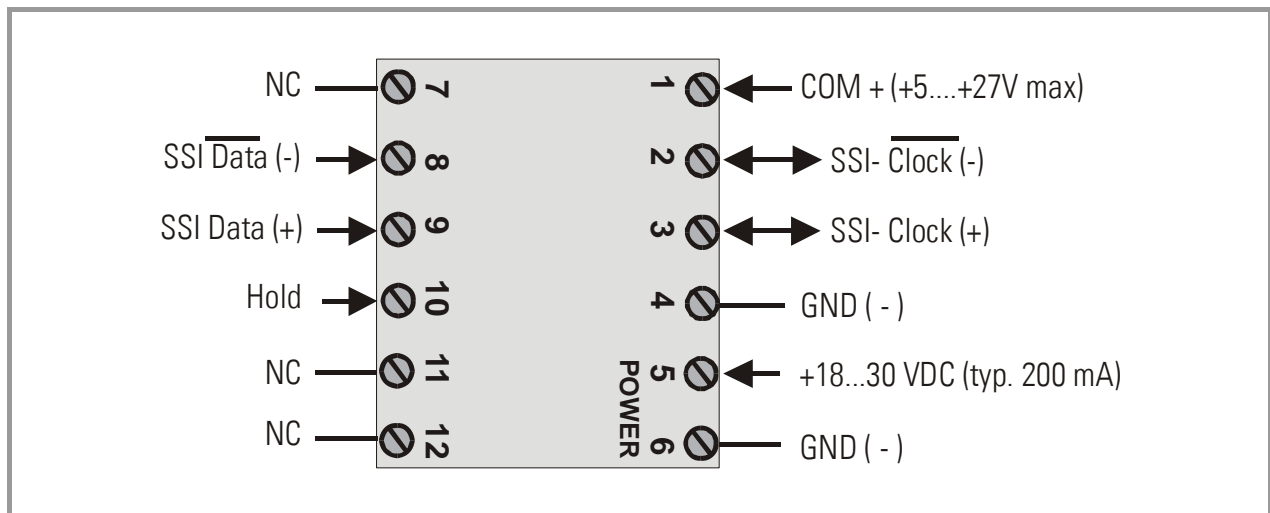

3. Connections

3.1. SSI encoder, Master operation

We recommend to connect the screen to GND and earth potential on both sites.

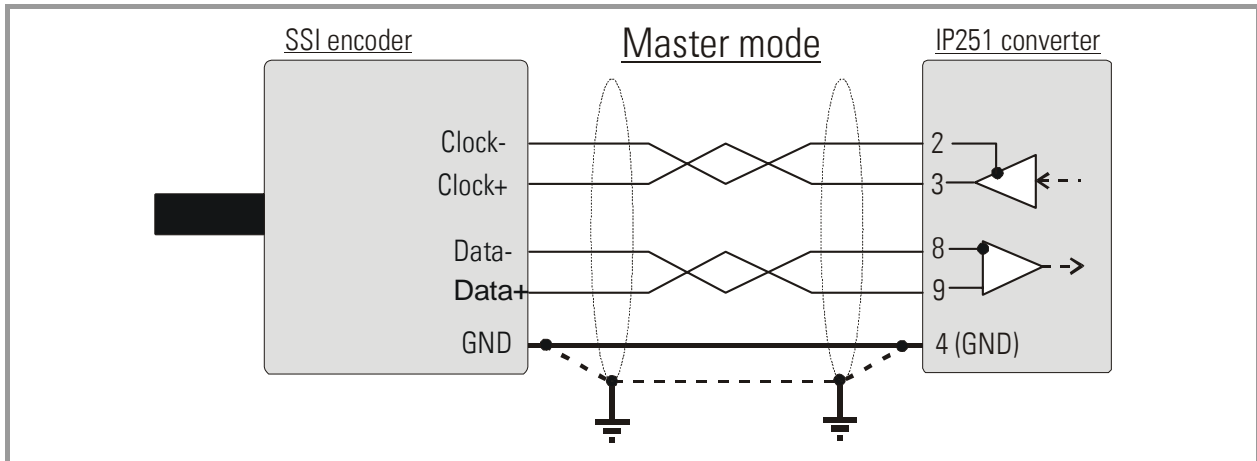

3.2. SSI encoder, Slave operation

With this mode, the IP251 converter operates in parallel to another unit, acting as a „listener“ to the existing data communication.

Quite according to need, the common potential of the master can be connected to terminal 4 (GND), or remain open for fully differential operation.

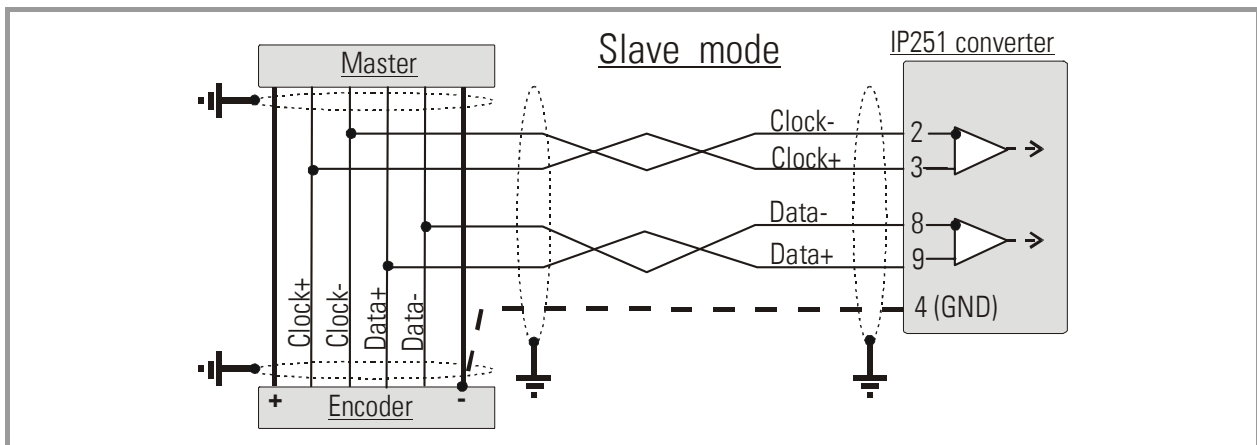

3.3. Hold input

A High signal to this input freezes the parallel output data.

The Hold function becomes active 500 μ sec after the rising edge of the signal and remains active for the duration of the signal. With PC setup, the polarity of the signal can be inverted (Falling edge, active low, see register "Hold polarity").

The Hold input provides PNP/HTL characteristics (Low = open or 0-3V, High =10-30V)

3.4. Parallel outputs

The unit provides 25 push-pull outputs which are short-circuit proof. The separate common output voltage for the outputs must be applied to screw terminal 1 (COM+)

The maximum voltage to COM+ should not exceed +27 volts, otherwise no continuous short-circuit proof of the outputs can be guaranteed.

The voltage drop between COM+ and an output in HIGH state is approx. 1 volt (unloaded)

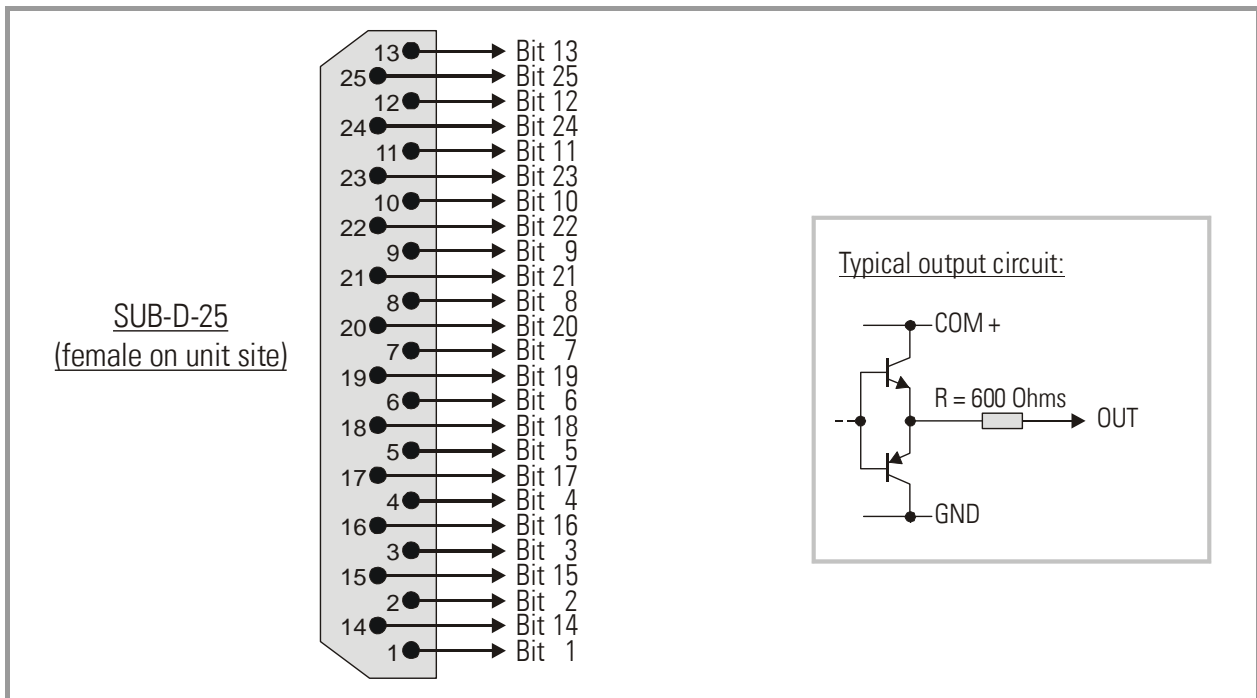

3.5. "Data stable" output

The output for bit 25 can be configured as a "Data-stable" signal by means of the DIL-switch. In this case a Low state indicates that parallel output data are stable and will not change.

The rising edge of the signal still guarantees stable data and can be used for remote Latch of the parallel data. The Low duration of the signal is at least 1/3 of the SSI Wait Time setting.

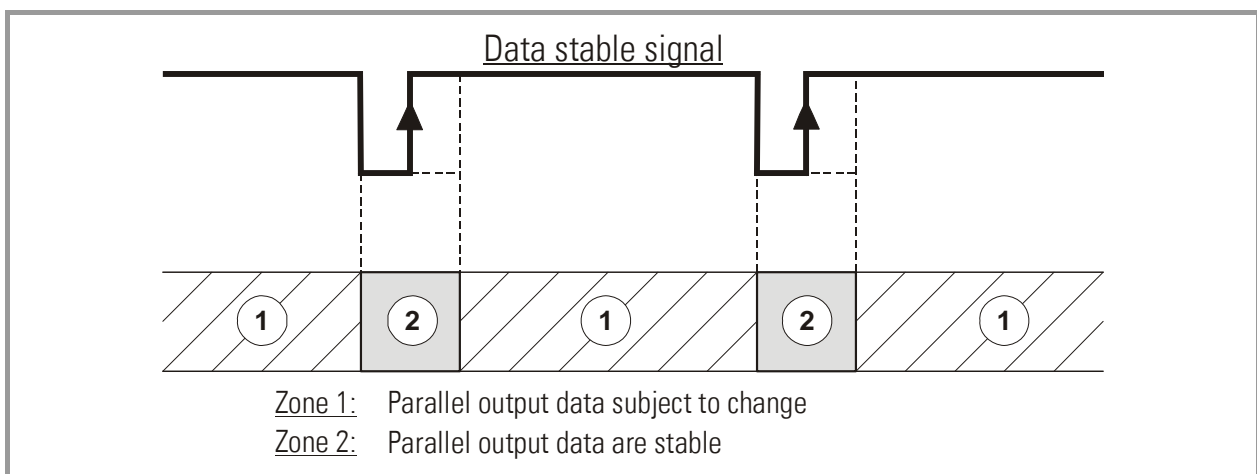

3.6. Serial interface

For PC setup and for serial readout of the encoder position, a serial RS232 interface is available.

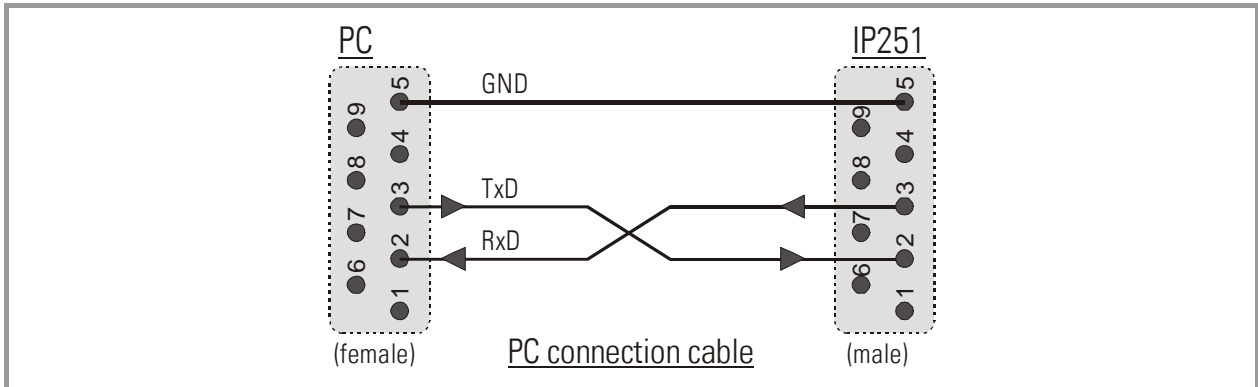
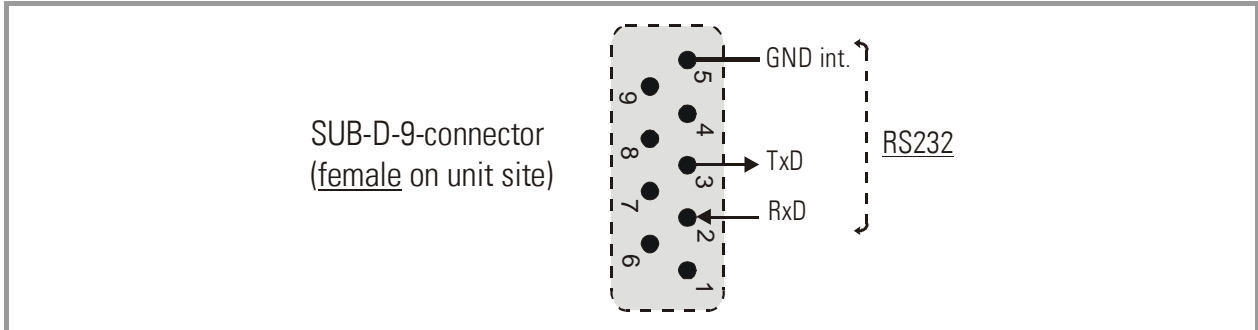

4. DIL Switch Settings

The DIL switch located on the top site of the unit provides encoder settings and customer-specific settings of the desired operation modes.



Changes of switch settings will become active only after the next power-up cycle!

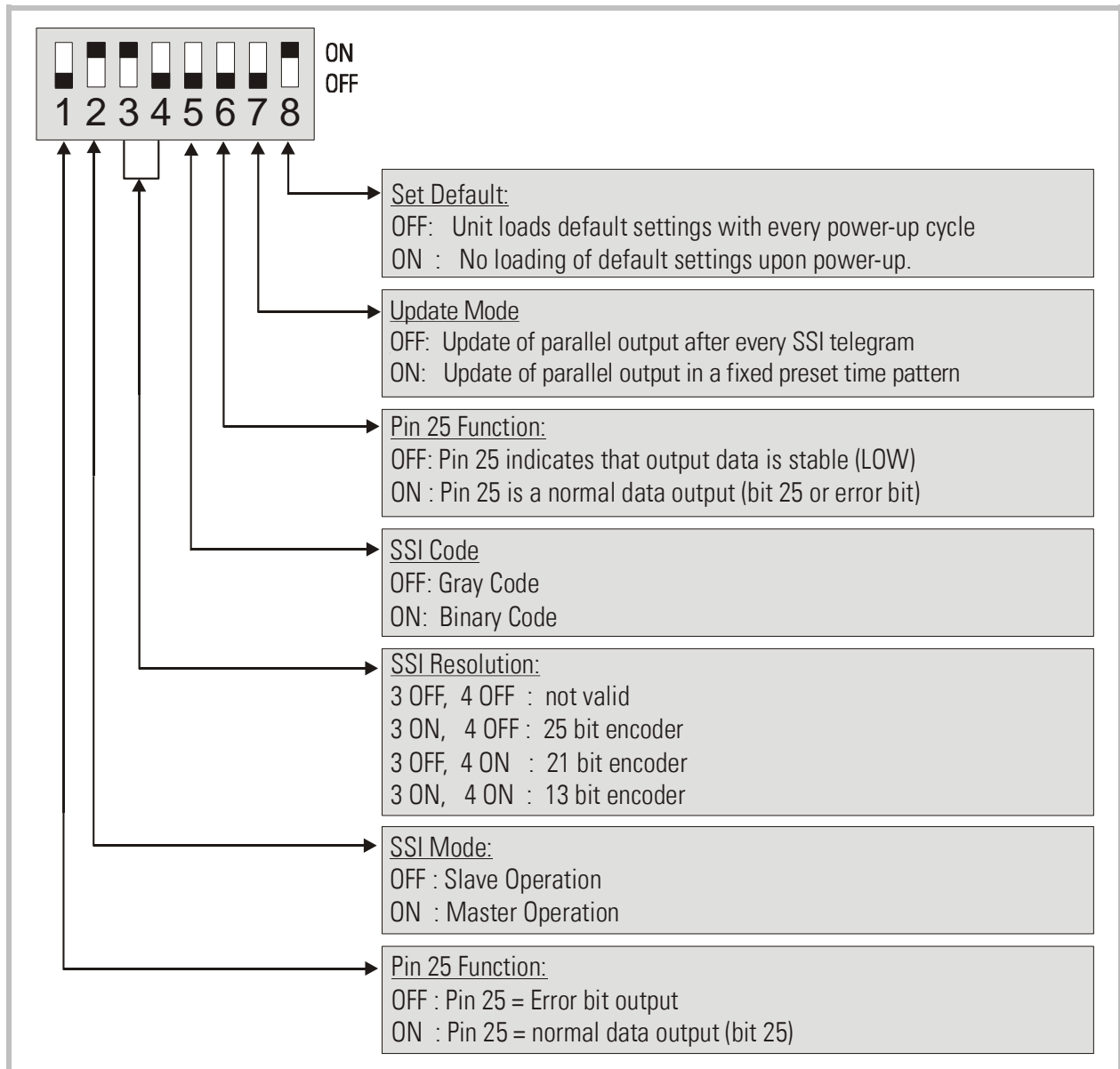

The switch settings shown in the example are suitable for Master operation of a 25 bit SSI encoder with Gray coded output. The parallel output operates with equidistant update times and pin 25 is used to indicate valid and stable output data.

5. Extended Functions with PC Setup

For normal use with **standard applications**, the unit is ready to work after correct wiring and setting of the DIL switches. In this case, **the subsequent sections are not relevant**.

With use of a PC however, you have full access to useful complementary functions and tests as shown subsequently. For this you will need the PC operator software OS3.x which is available for free download from

www.motrona.com

Connect your PC to the converter, using a serial RS232 cable like shown in section 3.6. of this manual. Then run the OS3.x software and you will see the following screen:

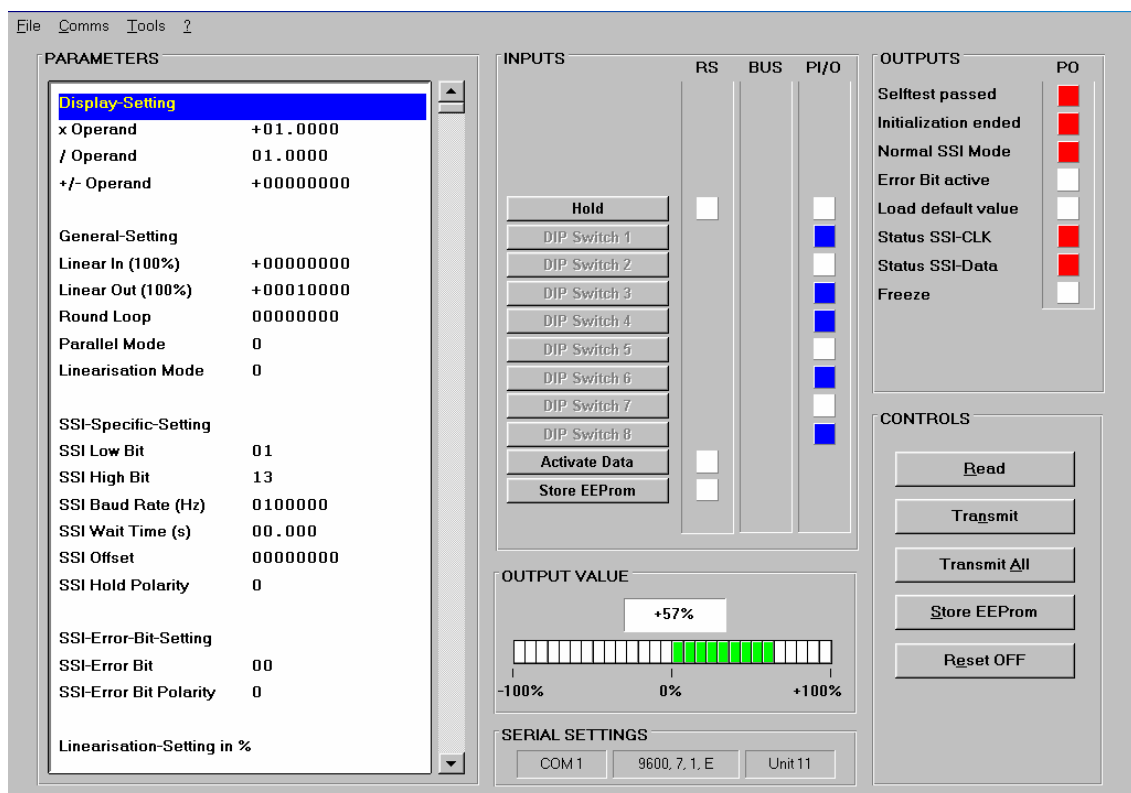

In case your text and color fields remain empty and the headline says „OFFLINE“, you must verify your serial settings. To do this, select „Comms“ from the menu bar.



Ex factory, all motrona units use the following serial standard settings:

Unit No. 11, Baud rate 9600, 1 start/ 7 data/ parity even/ 1 stop bit

If the serial settings of the unit should be unknown, you can run the „SCAN“ function from the „TOOLS“ menu to find out.

5.1. Self Test

On your PC screen, in the "Outputs" field, you find several indicator boxes.

When the "Self-test passed" box lights red, this indicates that the unit has correctly initialized and is ready to work. The fields "Status SSI-CLK" and "Status SSI-Data" indicate that the clock and data lines work correctly (red color = o.k.) *)

You may observe that these boxes blink, because of the update cycle of your PC. However, you should see "red" predominantly with correct operation of the lines.

5.2. Output value

When the encoder position is changing, this window must show increasing or decreasing encoder values. Where the color bar or the percentage display are jumping or hunting, please check once more for correct setting of the DIL switch.

5.3. Hold key

This soft key operates in parallel to the hardware input terminal 10 and allows freezing the parallel output from the PC screen. Indicator boxes in the RS column indicate that the Hold function is active, either by software or by hardware command.

*) Testing the clock lines is primarily useful with Slave operation. Though the test works also in Master mode, the result says only that the internal generation of the clock works fine. However, in Master mode, this test cannot indicate faulty clock drivers or bad wiring of the clock lines

6. Parameters

6.1. Scaling of serial readout data

You can read out the actual SSI position of the encoder at any time from the serial link. For setting of communication parameters (baud rate etc.) you need a PC.

IP251 uses the DRIVECOM communication standard according to ISO 1745. Details about this protocol can be found in the file [Serpro1a.doc](#),
(available for Download from www.motrona.com)

The serial access code for the actual encoder position is „ :8 “
(ASCII characters for colon and 8)

Serial data be re-scaled by using the parameters **xOperand**, **/Operand** and **+/-Operand** :

$$\text{Serial Readout} = \left[\text{SSI encoder data} \times \frac{\text{xOperand}}{\text{/Operand}} \right] + \text{+/-Operand}$$

There operands affect only serial readout of encoder data but not the parallel data output.
With the settings

$$\begin{aligned} \text{xOperand} &= 1.0000, \\ \text{/Operand} &= 1.0000 \\ \text{+/-Operand} &= 0.0000 \end{aligned}$$

the serial readout value equals to the SSI encoder value.

6.2. Scaling of parallel output data

6.2.1. If you like to convert the SSI encoder data to the parallel output straight 1:1

- | | | |
|----------------------|-----|---|
| ▪ Linearisation Mode | = 0 | |
| ▪ Round Loop | = 0 | |
| ▪ Parallel Mode | = 0 | (binary output) |
| | = 1 | (Gray coded output) |
| | = 2 | (BCD output) |
| ▪ Parallel Inv. | = 0 | (Log 1 = „High“, normal output polarity) |
| | = 1 | (Log 1 = „Low“, inverted output polarity) |

The settings of the Linearization registers are not important in this case.

6.2.2. If you like to convert the SSI encoder data to the parallel output with a different scaling:

Example: encoder 16 Bit = 65536 steps to be converted to a range of 0 - 10 000 on the parallel output

- Linearisation Mode = 1
- Round Loop = 0
- Parallel Mode = 0 (binary output)
= 1 (Gray output)
= 2 (BCD output)
- Parallel Inv. = 0 (Log 1 = „High“, normal output polarity)
= 1 (Log 1 = „Low“, inverted output polarity)
- Linear In (100%) = 65 536
Linear Out (100%) = 10 000
- P1 (x) = 000.0 %
P1 (y) = 000.0 %
P2 (x) = 100.0 %
P2 (y) = 100.0 %

6.2.3. If you like to transform the SSI encoder data to a curve on the parallel output site (Linearization)

Example: encoder 16 Bit = 65536 steps to be transformed to a programmable curve.

- Linearisation Mode = 1
- Round Loop = 0
- Parallel Mode = 0 (binary output)
= 1 (Gray output)
= 2 (BCD output)
- Parallel Inv. = 0 (Log 1 = „High“, normal output polarity)
= 1 (Log 1 = „Low“, inverted output polarity)
- Use registers **P1(x)** to **P16(x)** to specify the coordinates on the x-axis. These are the original SSI data generated by the sensor. These settings are in % of full scale
- Now enter the attached values to registers **P1(y)** to **P16(y)**. These are the values that the parallel output will generate instead of the x- values *)

*) Example:. P2(y) will substitute P2(x) etc.



- x-registers must follow continuously increasing settings, i.e. P1(x) must receive the lowest setting and P16(x) must receive the highest setting
- All entries use a percent format of xx.xxx% full scale. Setting 0.000% means zero output and setting 100.000% means full scale encoder output
- With Linearization Mode set to 1, it is a must to set P1(x) to 0% and P16(x) to 100%. Linearization is defined in the positive range only and the negative range will be a mirror image of the positive range with reference to zero.
- With Linearisation Mode set to 2, it is a must to set P1(x) to -100% and P16(x) to +100%. This enables the user to set curves which are not symmetric to the zero position

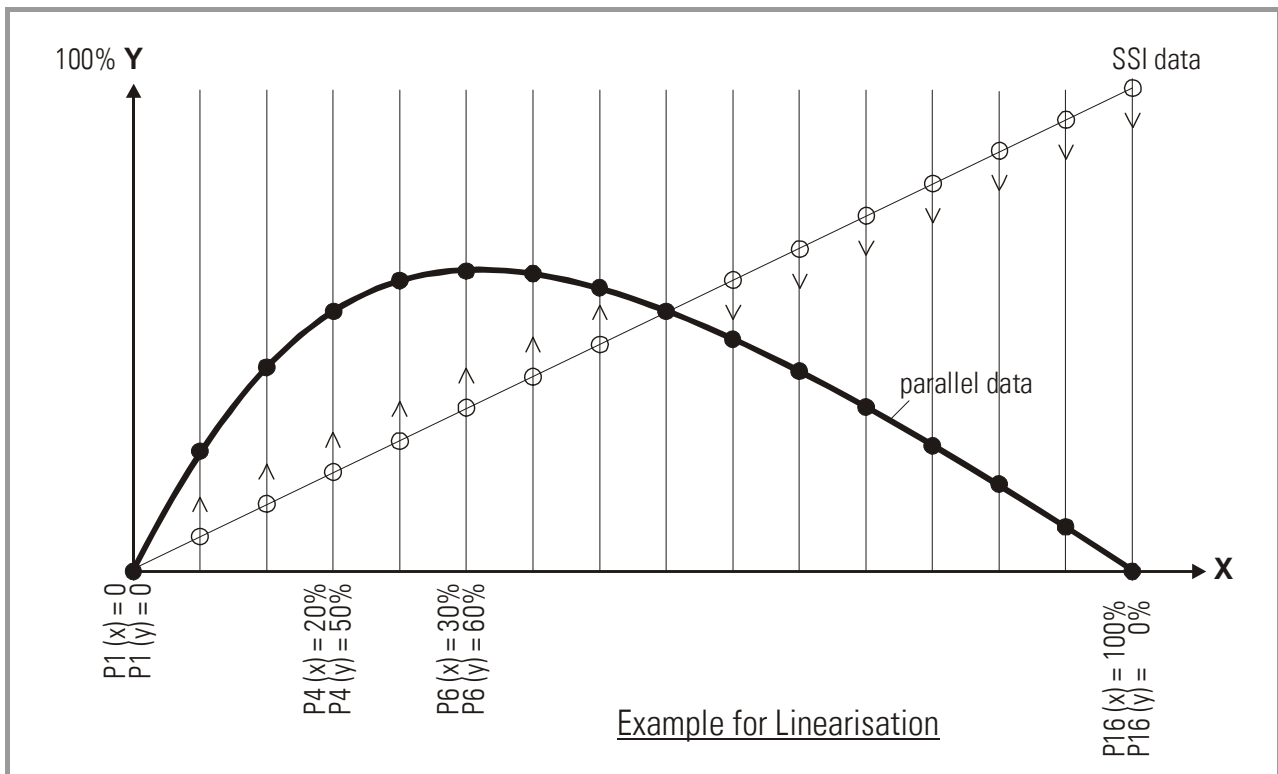

6.3. Ring counter, parameter "Round Loop":

In general, this setting should be 00000.

Any other setting will substitute the real encoder position by a repeating cycle count.

Example: when the Round Loop register is set to 2048, the internal position register will only count in a range between 0 and 2047. When we underpass zero with reverse direction, again 2047 will appear. When we exceed 2047 with forward direction, we will restart at 0 again.

The zero position of the round-loop counter can be set by register "SSI-Offset" which allows settings between 0 and the Round-Loop value. Register "Direction" allows to set the counting direction of the round loop counter (0 = up, 1 = down).

The following drawings explain the coherence between original SSI encoder data, Round-Loop setting, SSI-Offset and Direction register.

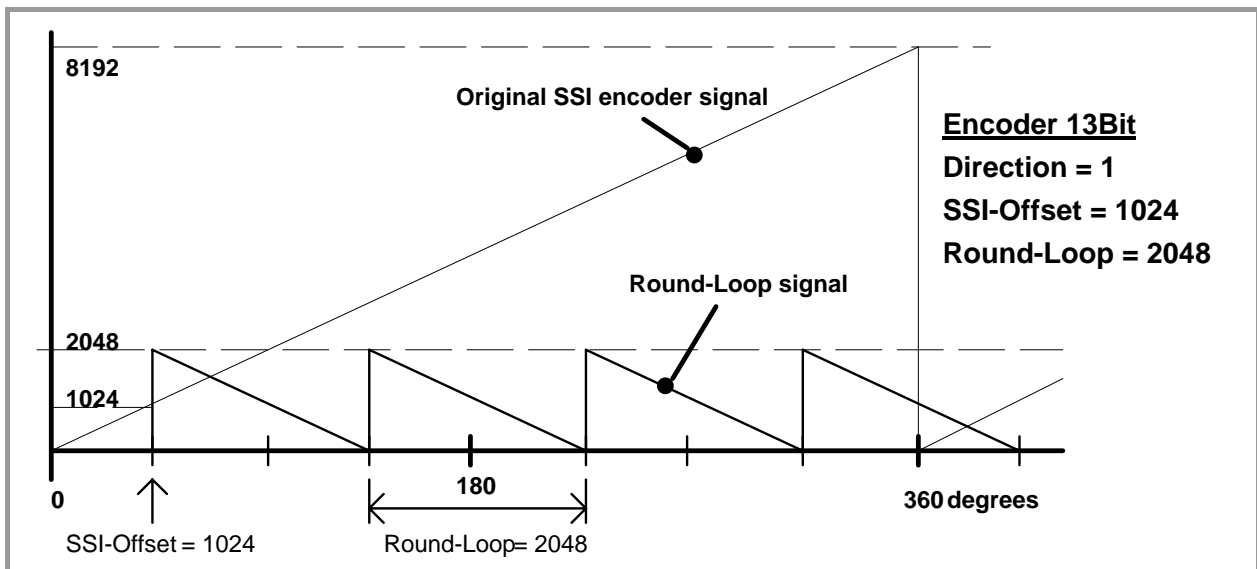
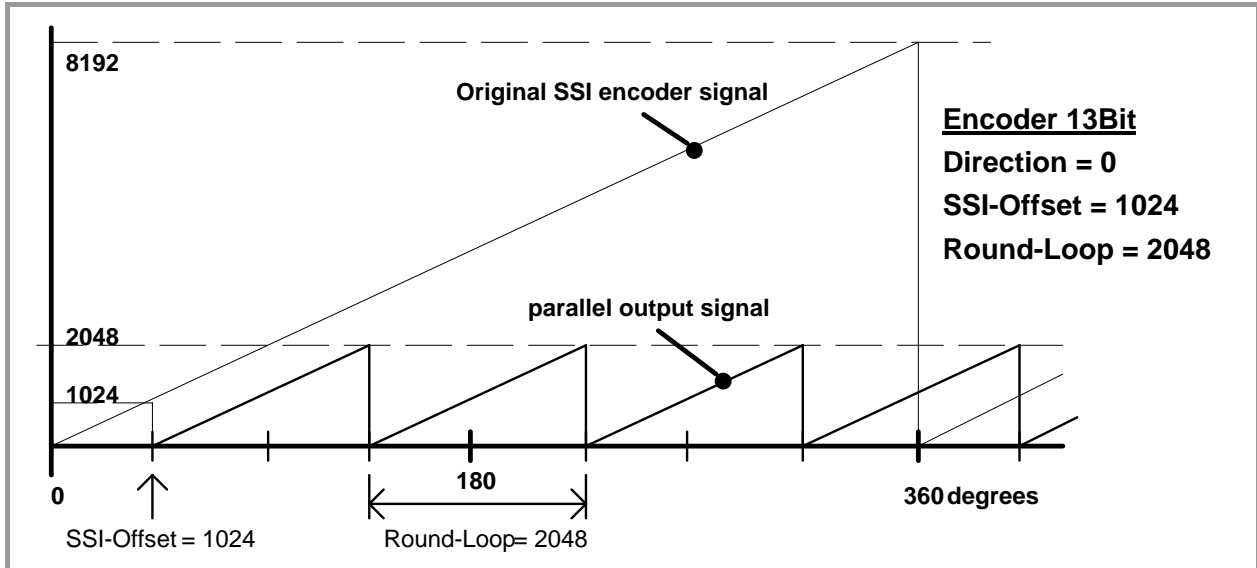

The Round-Loop function is also suitable to suppress the encoder overflow, if you do not like to change the mechanical situation. As shown in the subsequent picture, you need to set the Round-Loop register to the full encoder resolution and then shift the zero transition by setting the SSI Offset correspondingly.

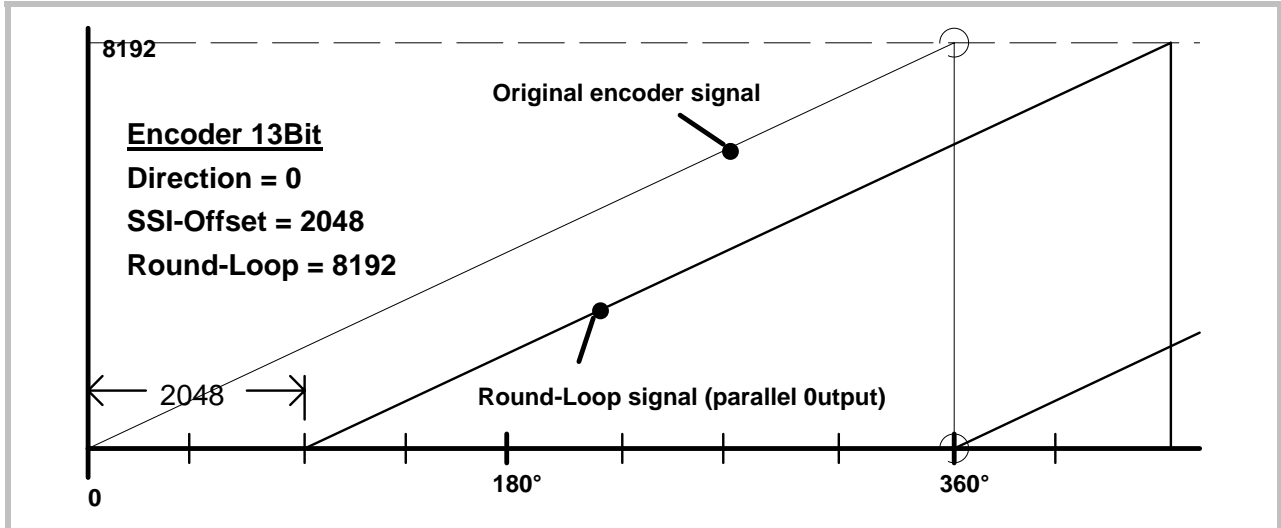

- Every change of the Round-Loop setting requires new entry the Offset values
- With use of the Round-Loop function it is also possible to change the counting direction of the encoder, by appropriate setting the direction bit.

6.4. More parameters:

Parameter	Description																	
Parallel Mode:	Sets the code of the parallel output and the input source of the converter.																	
	<table border="1"> <thead> <tr> <th>Parallel Mode :</th> <th>Parallel output</th> <th>Data source</th> </tr> </thead> <tbody> <tr> <td>0</td> <td>Binary format</td> <td rowspan="3">SSI encoder</td> </tr> <tr> <td>1</td> <td>Gray format</td> </tr> <tr> <td>2</td> <td>BCD format</td> </tr> <tr> <td>3</td> <td>Binary format</td> <td rowspan="3">Serial RS 232 interface</td> </tr> <tr> <td>4</td> <td>Gray format</td> </tr> <tr> <td>5</td> <td>BCD format</td> </tr> </tbody> </table>	Parallel Mode :	Parallel output	Data source	0	Binary format	SSI encoder	1	Gray format	2	BCD format	3	Binary format	Serial RS 232 interface	4	Gray format	5	BCD format
Parallel Mode :	Parallel output	Data source																
0	Binary format	SSI encoder																
1	Gray format																	
2	BCD format																	
3	Binary format	Serial RS 232 interface																
4	Gray format																	
5	BCD format																	
Linearisation Mode:	Sets the mode of linearization. 0: Linearisation off, all linearization registers are irrelevant. 1: Linearisation in a range of 0 – 100% 2: Linearisation over full range –100% to +100% <u>See example under section „Linearisation“</u>																	



Parameter	Description																									
<u>SSI Baud Rate:</u>	<p>Sets the communication speed of the SSI interface with SSI encoders. Setting range: <u>100 Hz to 1MHz</u>.</p> <p>You are free to <u>set</u> any desired frequency between 0.1 kHz and 1000.0 kHz. For technical reasons however, in the upper frequency range with Master operation, the unit will only <u>generate</u> one of the following frequencies accurately:</p> <table border="1" data-bbox="451 510 1409 734"> <tbody> <tr> <td>1 000,0 kHz</td> <td>888,0 kHz</td> <td>800,0 kHz</td> <td>727,0 kHz</td> <td>666,0 kHz</td> </tr> <tr> <td>615,0 kHz</td> <td>571,0 kHz</td> <td>533,0 kHz</td> <td>500,0 kHz</td> <td>470,0 kHz</td> </tr> <tr> <td>444,0 kHz</td> <td>421,0 kHz</td> <td>400,0 kHz</td> <td>380,0 kHz</td> <td>363,0 kHz</td> </tr> <tr> <td>347,0 kHz</td> <td>333,0 kHz</td> <td>320,0 kHz</td> <td>307,0 kHz</td> <td>296,0 kHz</td> </tr> <tr> <td>285,0 kHz</td> <td>275,0 kHz</td> <td>266,0 kHz</td> <td>258,0 kHz</td> <td>250,0 kHz</td> </tr> </tbody> </table> <p>With Master operation, therefore other settings will result in generation of the next upper or lower value according to above list. With all settings < 250.0 kHz the error between set rate and generated rate becomes negligible.</p>	1 000,0 kHz	888,0 kHz	800,0 kHz	727,0 kHz	666,0 kHz	615,0 kHz	571,0 kHz	533,0 kHz	500,0 kHz	470,0 kHz	444,0 kHz	421,0 kHz	400,0 kHz	380,0 kHz	363,0 kHz	347,0 kHz	333,0 kHz	320,0 kHz	307,0 kHz	296,0 kHz	285,0 kHz	275,0 kHz	266,0 kHz	258,0 kHz	250,0 kHz
1 000,0 kHz	888,0 kHz	800,0 kHz	727,0 kHz	666,0 kHz																						
615,0 kHz	571,0 kHz	533,0 kHz	500,0 kHz	470,0 kHz																						
444,0 kHz	421,0 kHz	400,0 kHz	380,0 kHz	363,0 kHz																						
347,0 kHz	333,0 kHz	320,0 kHz	307,0 kHz	296,0 kHz																						
285,0 kHz	275,0 kHz	266,0 kHz	258,0 kHz	250,0 kHz																						
	<p>It is mandatory to set the Baud rate also with Slave operation. In this case, however, the setting serves only to determine the pause time for correct synchronizations (pause is detected after 4 clock cycles). The unit automatically synchronizes with every remote clock signal within the specified Baud rate range.</p>																									
<u>SSI Wait Time:</u>	<p>This register sets the waiting time between two SSI telegrams in a range from 0.001 to 10.000 sec. In normal operation, due to processor cycle times, the real time may vary by 512 µsec. with respect to the preset time.</p> <p>The fastest sequence possible is 1.3 msec at a setting of 0.000.</p> <p>With Slave operation mode, the distance of the SSI protocols depends on the remote Master and the SSI Wait Time specifies the distance of evaluation data strings. Setting to 100 msec results in evaluation of one telegram only every 100 msec, even though the Master may have transmitted many telegrams more.</p> <p>Especially with applications of closed-loop control loops, it may be of advantage to have equidistant updating of the output (DIL switch 7 = OFF). This is possible with Master mode only and the Wait Time setting (must be >0) directly corresponds to the time pattern of updates.</p>																									

The subsequent drawing explains the timing with use of equidistant update mode with a SSI Wait Time setting of 3 msec.

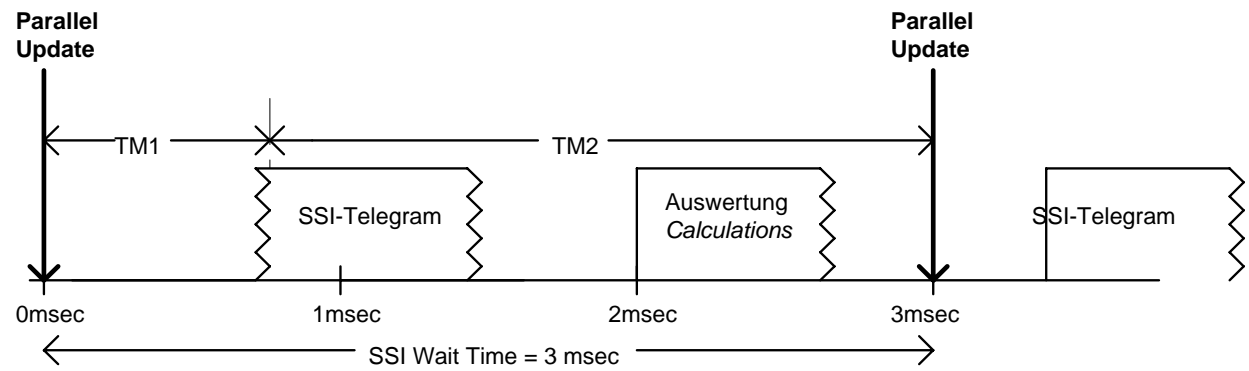
With equidistant operation mode, the SSI wait time setting is limited to maximum 90 msec.



- The shortest possible time for equidistant updating is 2 msec, due to internal processing times (SSI Wait Time set to 0.001). While your PC is communicating with the unit, it is even 5 msec.
- The time marks TM1 and TM2 shown in above diagram can be displayed with the Monitor function of the PC operator software. It is easy to understand that the sum of both times must be equal to the Wait Time setting, otherwise you must increase the Baud rate or choose a longer update cycle. (The serial access codes are :3 for TM1 and :5 for TM2)
- In critical cases you can reduce the internal processing times of the unit, by omitting the conversion of serial RS232 encoder data. For this, just set parameter "/Operand" to 00000

Parameter	Description
SSI Offset:	Defines the electrical zero position of the encoder with respect to the mechanical zero position. When the Round-Loop function is not active (Round-Loop = 0), the SSI Offset is subtracted from the SSI position reading, which can also cause negative results. When the Round-Loop is active, SSI Offset displaces the mechanical zero position, but always with only positive results.
SSI Hold Polarity	Sets the polarity of the Hold signal on terminal 10 (active high or active low) <p style="text-align: right;"> 0 : Hold = High,  1 : Hold = Low,  </p>

<u>SSI Error Bit:</u>	<p>Defines the position of the error bit (if available with the encoder in use).</p> <p>00: no error bit available 13: bit 13 represents the error bit 25: bit 25 represents the error bit etc.</p> <p>Errors indicated by the encoder can be read out via serial code :9 (semicolon nine, error indication = 2000hex). In case of an error, the "Error Bit active" box on the PC screen appears red.</p> <p>It is also possible to use pin 25 of the parallel output for error indication (see DIL switch settings).</p>
<u>SSI Error Bit Polarity:</u>	<p>Defines the polarity of the Error Bit</p> <p>0: Bit is LOW in case of error 1: Bit is HIGH in case of error</p>
<u>P01 (x), P01 (y) etc:</u>	<p>Linearisation registers (see section 6.2.3)</p>
<u>Direction:</u>	<p>This parameter changes the internal direction of counting (0 or 1), provided the unit operates in Round Loop mode.</p>
<u>Parallel Inv:</u>	<p>When you change this register from 0 to 1, the data on the parallel output will be inverted.</p>
<u>Parallel Value:</u>	<p>The numerical value of this parameter appears directly at the parallel output, provided the register „Parallel Mode“ has been set to a value greater than 2 before. The serial access code of Parallel Value is "48" and the setting can be changed at any time via serial link</p> <p>This function may be useful for testing of function and wiring of the parallel output</p>
<u>Unit Number:</u>	<p>You can choose any serial address number between 11 and 99. Factory setting = 11</p> <p>The address must <u>not</u> contain a "0" because these numbers are reserved for collective addressing.</p>

7. Test Functions

When you select TEST from the TOOLS menu, you are able to verify the following data, by clicking to the corresponding field:

Actual encoder position, DIL switch settings, Internal supply voltages, Parallel output state

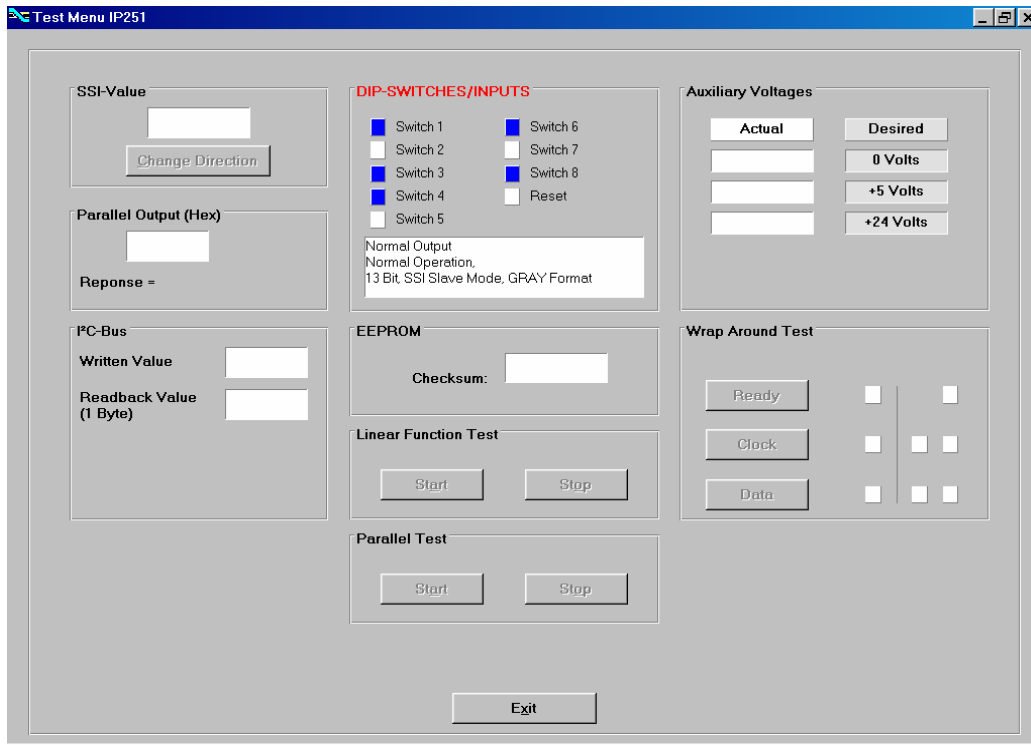

Furthermore, the following registers can be recorded by using the monitor function:

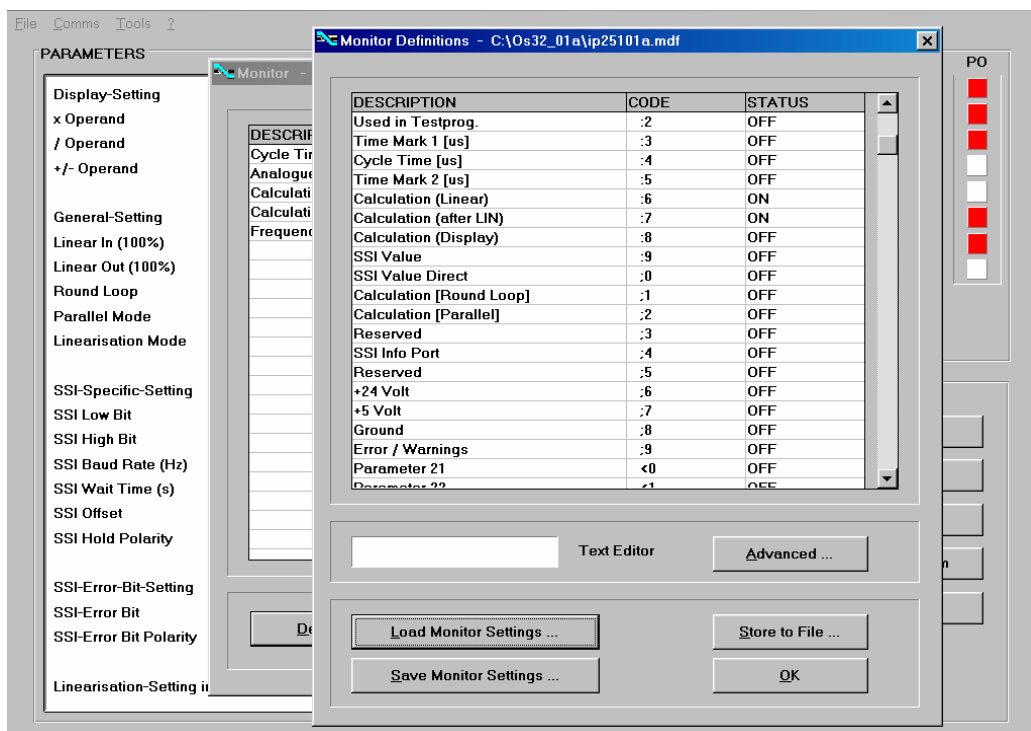

8. Specifications and Dimensions

Power Supply	:	18...30 VDC
Power consumption	:	approx. 200 mA
SSI Inputs	:	TTL differential, RS422 standard (1.0 MHz)
SSI Input Format	:	13, 21 or 25 Bit, Gray Code or Binary Code
SSI break time	:	min. 4 clock cycles
Hold input	:	HTL, PNP-switching, High > 10V , Low < 3V (Ri = 5k)
Parallel outputs	:	max. 35V at COM+ *) Load 1.2k at 24V + 10% (Ri = 600 Ohm)
Parallel Output Format	:	Binary / Gray / BCD Code
Temperature-Range	:	Operation: 0° ... +45°C (+32 ... +113°F) Storage: -25° ... +70°C (-13 ... +158 °F)
Weight	:	approx. 190 g
Conformity and Standards	:	EMC 89/336/EEC: EN 61000-6-2 EN 61000-6-3 LV73/23/EEC: EN 61010-1

*) Short circuit proof can be guaranteed only up to +27 Volts max.

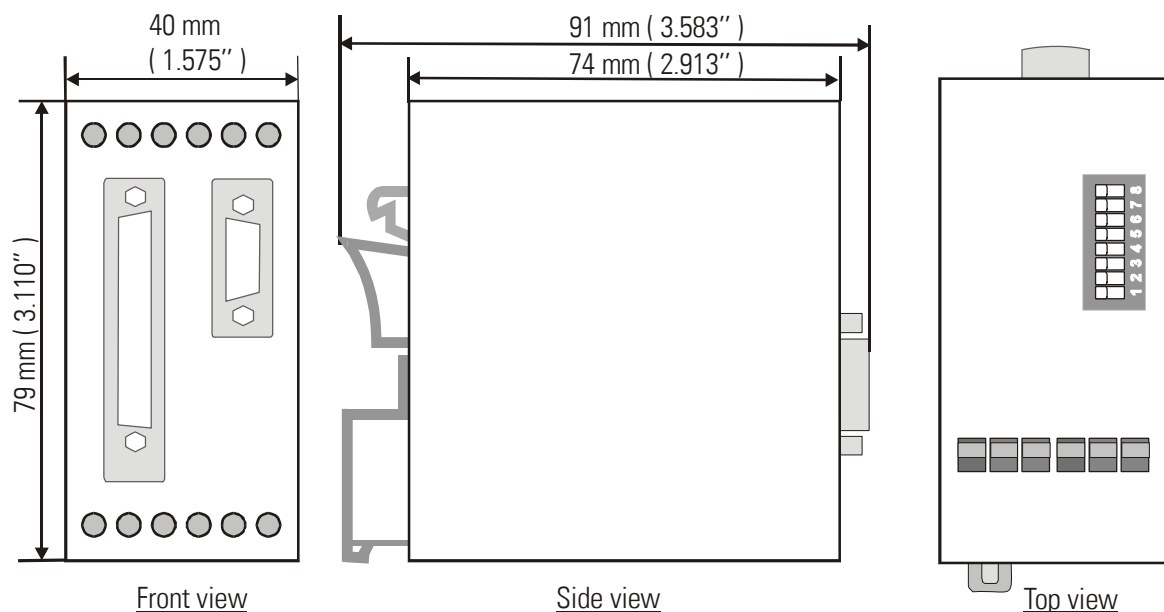

9. Parameter List, Default Settings

Parameter	Min. value	Max. value	Default	Pos.	Char.	Ser. Code
X Operand	-10.0000	+10.0000	1.0000	+/- 6	4	00
/ Operand	0	10.0000	1.0000	6	4	01
+/- Operand	-99999999	99999999	0	+/- 8	0	02
Linear In	-99999999	+99999999	0	+/- 8	0	03
Linear Out	-99999999	+99999999	10000	+/- 8	0	04
Round Loop	0	99999999	0	8	0	05
Parallel Mode	0	2	0	1	0	06
Linearisation Mode	0	2	0	1	0	07
SSI Low Bit	0	25	1	2	0	08
SSI High Bit	1	25	25	2	0	09
SSI Baud rate	100	1000000	100000	7	0	10
SSI Wait Time	0	10.000	0	5	3	11
SSI Offset	0	99999999	0	8	0	12
SSI Hold Polarity	0	1	0	1	0	13
SSI Error Bit	0	25	0	2	0	14
SSI Error Bit Polarity	0	1	0	1	0	15
P1(x)	-100.000	+100.000	100000	+/- 6	3	A0
P1(y).....	-100.000	+100.000	100000	+/- 6	3	A1
P16(x)	-100.000	+100.000	100000	+/- 6	3	D0
P16(y)	-100.000	+100.000	100000	+/- 6	3	D1
Direction	0	1	0	1	0	46
Parallel Inv	0	1	1	1	0	47
Parallel Value	-999 999	33554431	+/-8	5	0	48
Unit Number	0	99	11	2	0	90
Serial Baud Rate	0	6	0	1	0	91
Serial Format	0	9	0	1	0	92