

# LRB1000 / LRB2000

## DIN Rail Mount Speed Switch

### Principles of Operation

The LRB Series Switch is supplied with a shaft mounted magnetic disc or wrap which generates an alternating magnetic field that is picked up by the non-contact sensor. The sensor transmits this speed signal as a digital pulse (frequency) to the switch via a 3-conductor shielded cable. The LRB Switch decodes this frequency signal to determine shaft speed, and compares this to its adjusted set point(s). This comparison in conjunction with the choice of under speed or over speed mode, allows the relay output to be used for alarm and/or shutdown, assuring optimum machine protection and process integrity. A feature of the LRB-Series Switch is the ability to mount the switch on a DIN rail. This is useful for installation where plant electrical controls are centrally located in a control cabinet. Consult Electro-Sensors, Inc. for information on enclosures if needed.

The LRB-Series Switch System includes the terminal block mounted switch, a non-contact Hall-Effect sensor and a magnetic disc or optional pulser wrap. The Model 906 sensor is designed for standard service. An optional explosion proof sensor Model 907 is available for hazardous locations. The sensor is connected to the terminal block on the LRB Series Switch (figure 3).

### Start Delay

A 10-second Start Delay is built into the LRB Series Switches. In Under Speed Mode, the Start Delay holds the relay(s) in an energized state for 10 seconds, allowing the monitored shaft to reach a speed above the set points(s) before monitoring begins. The Start Delay begins when power is applied to the LRB Series Switch.

### Signal Loss Protection

In Under Speed Mode, a loss of the sensor signal will be detected and the relay will de-energize. In Over Speed Mode, the loss of signal is detected and the LRB Series Switch will wait 30-seconds for the signal to resume, preventing unwanted signal loss shutdown when monitoring a very slow speed shaft. After the 30-second interval has elapsed with no incoming signal, the relay is de-energized.

### Special Options

Special options are available from the factory to modify the standard functions of the LRB Series Switches. Options include: Increased, decreased or zero start delay; increased or decreased setpoint hysteresis; extended ranges; and signal loss protection deactivation in over speed mode.

### Pulser Disc

To mount the Pulser Disc, center drill the monitored shaft to a depth of 1/2 inch with a No. 21 drill and tap it for a 10-32 UNF screw. Apply Loctite™ or a similar adhesive on the screw threads to keep the pulser disc tight. Attach the disc, decal side out, with the 10-32 UNF machine screw provided. Pulser Discs can be used with all Electro-Sensors, Inc. sensors.

### Pulser Wrap (optional)

Pulser wraps are custom manufactured to fit the specific diameter of the shaft on which they will be mounted. To mount the wrap, remove the 4 Allen-head cap screws holding the halves of the wrap together, place the halves around the shaft, and reinsert the screws. Tighten the screws to 5 ft. lbs. Pulser Wraps can be used with all Electro-Sensors, Inc. sensors.

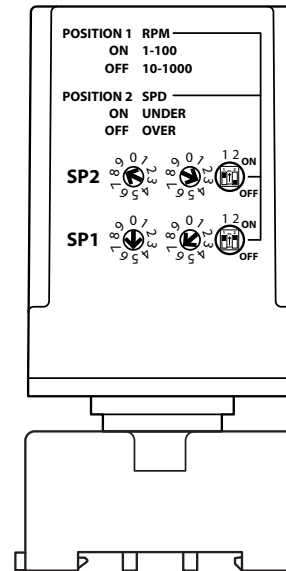

### Sensor Installation

The standard sensor is supplied with a mounting bracket and two jam nuts. The explosion proof sensor is supplied with a slotted mounting bracket. Sensors should be installed so the center line of the magnets pass in front of the center of the sensor as the disc or wrap rotates. When using the pulser disc, the center of the magnetized area of the disc, shown as Dimension B in figures 1 and 4, is 1-3/4 inches from the center hole of the disc. The recommended gap distance between the sensor and the disc or wrap, Dimension A in the diagrams, is 1/4-inch ± 1/8 inch. To achieve the proper gap distance, adjust the jam nuts holding the standard sensor in the mounting bracket, or adjust the position of the explosion proof sensor using the slots on its mounting bracket.

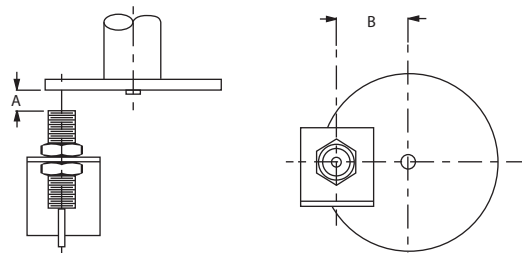

Figure 1: Standard 906 Sensor and Pulser Disc

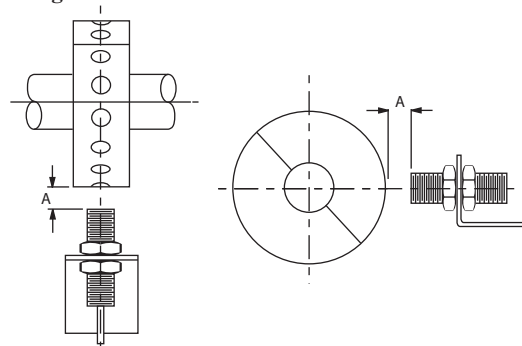

Figure 2: Standard 906 Sensor and Pulser Wrap

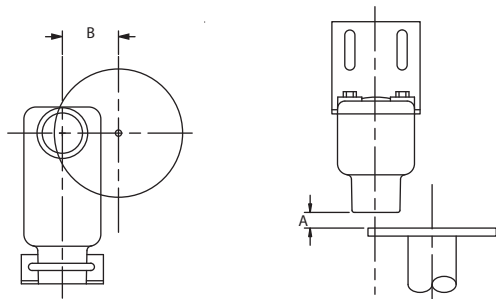

Figure 4: Explosion proof 907 Sensor and Pulser Disc

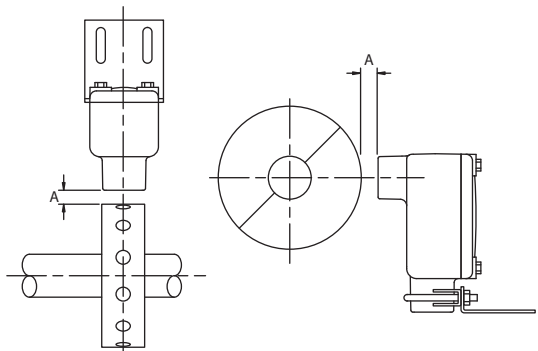
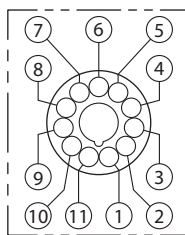

Figure 5: Explosion proof 907 Sensor and Pulser Wrap



Terminal	Connection
1	Relay Common (SP1)
2	Hot +
3	Relay N.O. (SP1)
4	Relay N.C. (SP1)
5	Sensor Supply
6	Sensor Signal
7	Sensor Ground
8	Relay N.C. (SP2)
9	Relay N.O. (SP2)
10	Neutral -
11	Relay Common (SP2)

Figure 3: Base Wiring Diagram

Switch 1	Set Point
ON	1 - 100 RPM
OFF	10 - 1000 RPM

Switch 2	Mode
ON	Underspeed
OFF	Overspeed

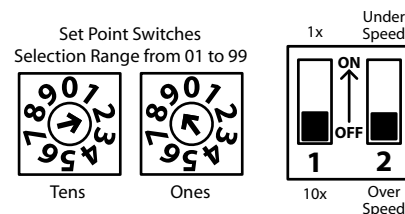

Figure 6: Setpoint Setup

**Sensor Connection Table**

Terminal	ESI 906	ESI Prox ESI 907	All Other ESI Sensors	ESI 907 Old
5 Supply	Red	Brown	Red	Red
6 Signal	Black	Black	White	Black
7 Common	White & Shield	Blue & Shield	Black & Shield	White & Shield

**Power Input Table**

Terminal	12 & 24 VDC	115 VAC	230 VAC
2	(+) Positive	Hot	Hot (L1)
10	(-) Negative	Neutral	Hot (L2)

**Relay Connections**

Terminal	Setpoint 1	Terminal	Setpoint 2
1	Common	11	Common
3	N.O.	9	N.O.
4	N.C.	8	N.C.
<b>LRB 1000/2000</b>		<b>LRB 2000 ONLY</b>	

**There are 3 steps to calibrating the LRB 1000/2000**

1. Determine whether the relay should de-energize when the shaft speed drops below the set point speed (Under Speed Operation,) or when the shaft speed goes above the set point speed (Over Speed Operation.) Use the Over/Under Speed Selection Switch to place the LRB 1000 in the desired mode (see Figure 6, for switch position.)
2. If the set point will be set to trip the relay at a speed below 100 rpm, set the Set Point Range Selection Switch to the 1-100 rpm range. If the set point will be set to trip the relay at a speed that is above 100 rpm and below 1000 rpm, select the 10-1000 rpm range
3. Set the Rotary Set Point Switches to the desired set point speed. The switches can be set at any number from 01 to 99.

**For example:**

If the RPM Range Selection Switch is set in the 1—100 rpm Range and the desired set point speed is 50 rpm, the Set Point Switches should be set to 50. In the 10 to 1000 rpm range, the set point is 10 times the switch setting (i.e. a switch setting of 80 results in a set point of 800 rpm.)

**NOTE:** Calibration should be done with power to the LRB 1000 turned OFF. If a change is made to the calibration while power is ON (Not Recommended,) cycle power to the unit. This will store the new set point.

The standard pulser disc or wrap will produce 8 PPR.



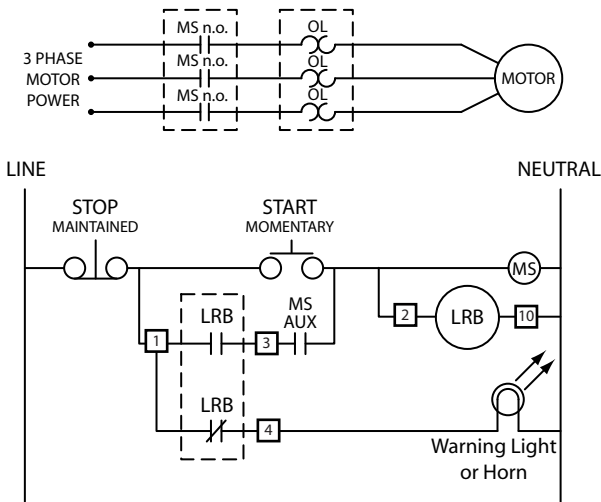

Figure 7: Typical Wiring Diagram

This Wiring Configuration Will Disable the Alarm on a Stop Command. To Maintain the Alarm, Replace the Maintained Stop Switch with a Momentary Normally Closed Switch

**WARNING!**

During a stopped condition, even a slight movement of the shaft magnet disc could energize the control relay and start the motor if the Motor Starter Auxiliary Normally Open Contact (MS Aux N.O.) is not wired in series as shown in these typical wiring diagrams. This situation could cause equipment damage or PERSONAL INJURY! To prevent starting the motor accidentally, ALWAYS USE PROPER LOCK-OUT/TAG-OUT PROCEDURES.

**LRB 1000/2000 Dimensions:**

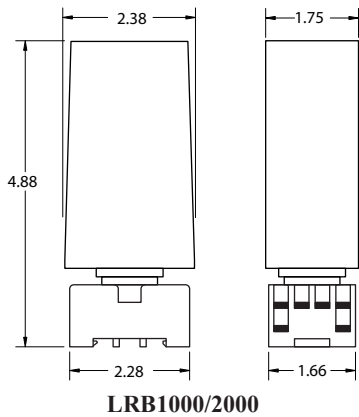

LRB1000/2000

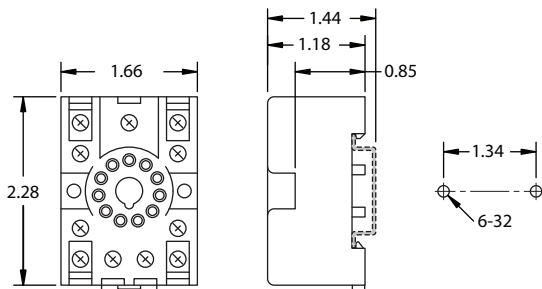

Terminal Block

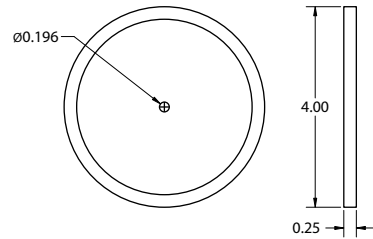

Pulser Disc

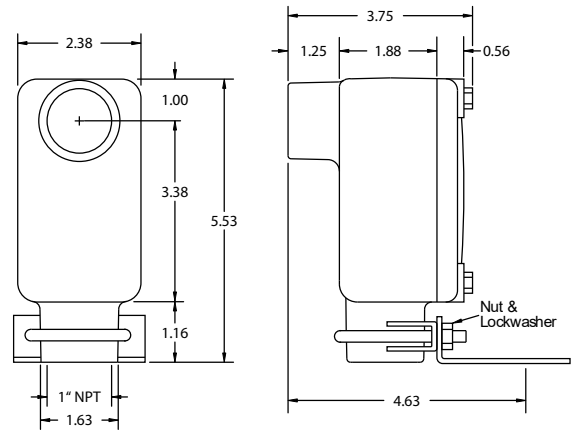

Explosion proof 907 Sensor

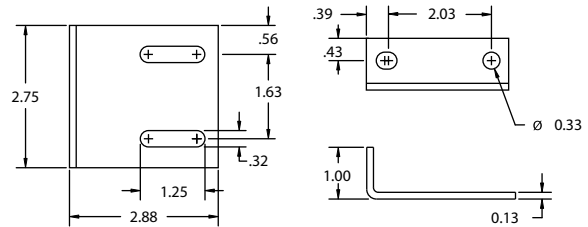

Explosion proof 907 Sensor Bracket

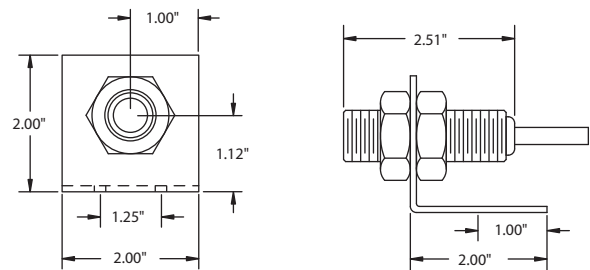

Standard 906 Sensor



## Troubleshooting Guide

Problem	
Relay will not Energize, LED does not "Light Up"	
Possible Solutions	
AC power is not applied to the LRB terminal block correctly.	Check input power connection table
Sensing head is not aligned or gapped properly.	See pages 1 & 2. Figures 1, 2, 3, 4
The set point is not in the proper range.	See page 2, Figure 5
Shaft is not turning faster than the set point.	Check actual RPM.
Sensing head is not wired correctly to the LRB Speed Switch.	Check Sensor Connection table on page 2 for correct wiring
Sensor Supply Voltage is not present.	Check for approx. 12 VDC between TB5 & TB7
LRB Speed Switch is not receiving signal.	Check for approx. 2.5 VDC between TB6 & TB7 with shaft running

## LRB 1000/2000 Specifications:

Input Voltage ±10%	Input Current	Fuse Type
<b>LRB1000/2000 (with standard ESI sensors)</b>		
115 & 230 Vac, 50/60 Hz	2.5 vA	0.032A Slo-Blo 5X20
<b>LRB1000 (with standard ESI sensors)</b>		
12 & 24 Vdc	45 mA	80 mA Slo-Blo 5X20
<b>LRB2000 (with standard ESI sensors)</b>		
12 & 24 Vdc	75 mA	125 mA Slo-Blo 5X20



Input Signal	Parameters
Sensor Supply	12 VDC (unregulated) @50mA Max
Type	Open Collector/Logic
Amplitude	5V Pull-Up
Pullup	2200 Ohms to 5V
Max Frequency Input	500Hz **
Min. Pulse Width	1 mSec

Set Point Data	Parameters
Number of Set Points	One or Two
Actuation State	Under or Over Speed
Set Point RPM Range	1 - 99 RPM 10 - 990 RPM **
Adjustment	Rotary Switches: 1 (10x) 1 (1x)
Set Point Accuracy	0.005% @ Low range 0.25% @ Mid Range 0.5% @ Top Range
Hysteresis	6.6% **
Contact Arrangement: LRB 1000: LRB 2000:	One Form C, SPDT Two Form C, SPDT

Relay Contact Rating	5 Amp @ 30 Vdc, or 250 Vac resistive
Start Delay	10 Seconds (Fixed) **

Physical/Environment	Parameters
Electrical Connection	11 - Position DIN Rail Terminal Block
Operating Temperature	-40°C to +60°C
Storage Temperature	-65°C to +125°C
Mounting	DIN Rail Mount or Stand Alone
Enclosure Rating	NEMA 1
UL508 Approved 	UL File# E254289

906 Sensor	Parameters
Body Material	Aluminium
Bracket Material	Steel
Thread Size	3/4 - 16 UNF
Output Type	Open Collector, Current Sinking 20 Ma Max
Signal Cable	3 - Conductor Shielded 10 ft. supplied std.
Max Cable Length	1500 Ft.
Operating Temperature	-40°C to +60°C
Air Gap	1/4 in. +/- 1/8 in. with standard 255 Pulser disc (1/2" magnets)

907 Explosionproof Sensor (optional)	Parameters **
 Class I, Div 1, Group D Class II, Div 1, Groups E, F, G UL File: E249019 	
Mounting Bracket Material	Plate Steel U-Bolt Assembly
Other Specifications	Similar to 906 standard sensor

Pulser Disc	Parameters
Material	Nylon 12 Std. Aluminum Optional
Operating Temperature	-40°C to +60°C
Maximum Speed	Consult Factory

Pulser Wrap	Parameters
Material	Consult Factory
Operating Temperature	-40°C to +60°C
Maximum Speed	Consult Factory

**Specifications are subject to change without notice.**  
**\*For higher temperature ranges, consult factory.**  
**\*\* Other settings available, consult factory.**