

Firmware BY 701.06

for use with motrona
 motion controller types
 MC 700 and MC720



Application example:
 Multi color printing machine with individually
 driven Screen rolls.

- Precision angular synchronization of up to 4 axis
- Operation with physical master (incremental encoder) or virtual master with selectable ramps and speeds
- Outstanding control facilities for relative position and phase, with index- and print mark signals
- Suitable for "stand-alone" operation as well as for connection to Field bus systems (CAN-Bus, PROFIBUS etc.)

Operating Instructions



Safety Instructions

- This manual is an essential part of the unit and contains important hints about function, correct handling and commissioning. Non-observance can result in damage to the unit or the machine or even in injury to persons using the equipment!
- The unit must only be installed, connected and activated by a qualified electrician
- It is a must to observe all general and also all country-specific and application-specific safety standards
- When this unit is used with applications where failure or maloperation could cause damage to a machine or hazard to the operating staff, it is indispensable to meet effective precautions in order to avoid such consequences
- Regarding installation, wiring, environmental conditions, screening of cables and earthing, you must follow the general standards of industrial automation industry
- - Errors and omissions excepted –

Version:	Changes:
BY70101A/ HK/ TJ/ June 2003	Original Version
BY70102A/ TJ/ June 2004	Sampling Time, Factor1 Min./Max., Error Messages, decimal serial codes
BY70103A/ TJ/ Feb. 2005	License added
BY70104A/ TJ/ June 2008	I/O assignment added
BY70105A/ TJ/ August 2008	Automatic factor correction; Vir.Master Frequency +/- inputs
BY70106A/ TJ/ November 2010	Virtual master reversible, Virtual master index, individual print mark windows for all drives

Table of Contents

1. Preamble	4
2. General remarks about functions of this firmware	5
3. Who is Who? Master-Slave Assignments	6
4. Pulse Scaling.....	7
5. Ratio Change during Operation.....	10
6. Change of Phase and Relative Position	11
6.1. Phase Adjustment by Timer Trimming	11
6.2. Phase Adjustment by External Pulse Stepping	11
6.3. Phase Adjustment by Digital Phase Offset	11
7. Index Registration and Control	12
8. Download Procedure	14
9. How to use the operator software.....	16
9.1. I/Os (Inputs and Outputs)	16
9.2. General Parameters.....	23
9.3. Parameter Blocks.....	25
9.4. Process data (actual values).....	34
10. Function of the LED indicators	35
11. Error messages	36
12. Steps for Commissioning	37
12.1. Preparations	37
12.2. Direction of Rotation	38
12.3. Tuning the Analogue Output	39
12.4. Setting of the proportional Gain	39
12.5. Hints for final operation	40
13. Hints for controller type MC720 with integrated operator terminal.....	41
13.1. Setting of parameters and registers	41
13.2. Display of actual process values.....	41
14. Parameter tables.....	43

1. Preamble

This document provides all information about the BY701 firmware, including parameters, variables and hints for commissioning.

To implement this application, you will need:

1. A motion controller hardware of types MC700 or MC720
2. A PC or Laptop with operating system Windows 95, 98, NT, 2000 or XP and serial interface (RS232)
3. The motrona CD containing the PC operator software OS5.1, the firmware file BY701xxx.ecr and the pdf files for the manuals MC700xxx.pdf (hardware description, connections, and specifications) and BY701xxx.pdf (description of the firmware as actually at hand)

All of above files are also available for free download from our homepage:

www.motrona.com

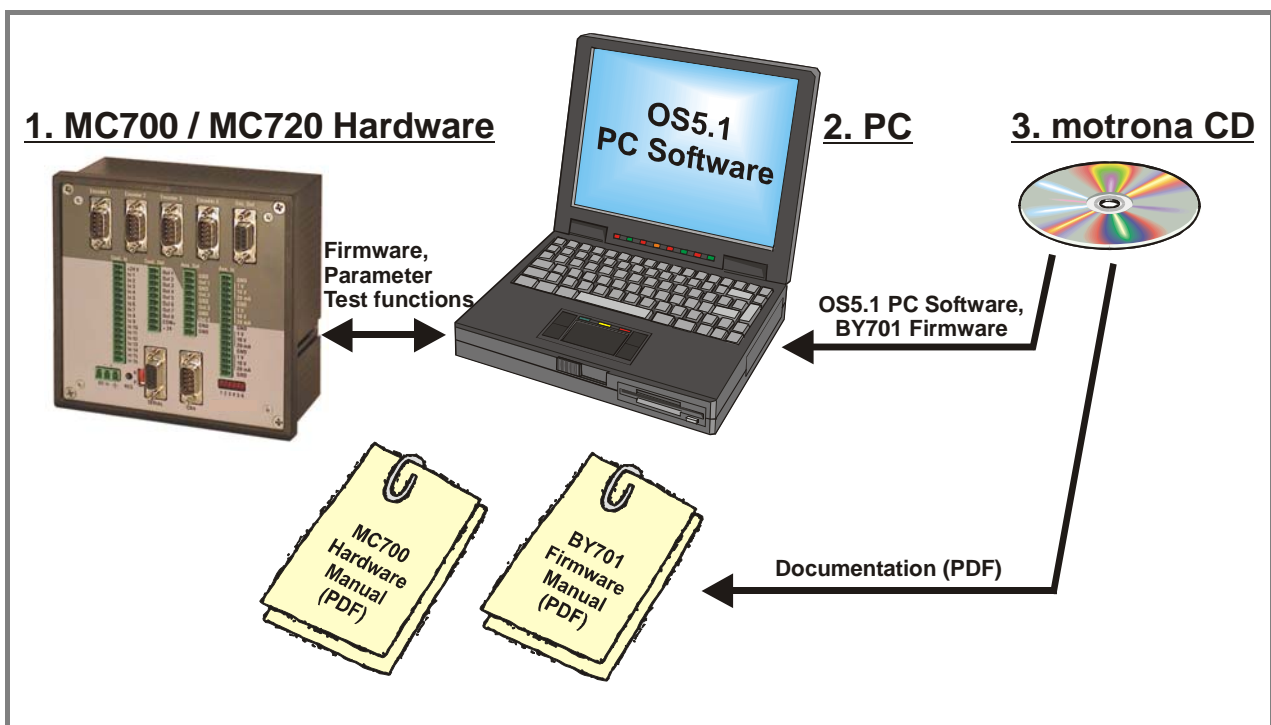

Moreover, at the "Applications" site of above homepage you can watch a short demo movie (movie No.1), showing a typical application of the firmware described here.

The BY701 firmware is liable to payment of a license fee and can only be used with the corresponding license key!

2. General remarks about functions of this firmware

The BY 701 firmware is suitable for applications requiring either an angular synchronization of drives (electronic shaft) or adjustable ratio synchronization (electronic gearbox).

Short control loop cycles (approx. 1 ms) combined with the smart algorithms of calculation provide excellent accuracy, efficiency and performance.

One controller type MC700 or MC720 can operate up to 4 axes. There are outstanding features for change of speed ratios and angular phase conditions available, working in standstill or on the fly, and also index and print mark registration is included.

By software, every drive can be assigned to follow either to a physical master or to a virtual master.

As a physical master (see application A) any remote motion can be used that is monitored by an incremental encoder. But also Slaves under control of the unit can again be defined as master of another drive.

As a virtual Master (see application B), a fictive drive inside the controller is used, of which the speed and the acceleration/deceleration ramps can be set by software. All slaves then follow increment by increment to this fictive master drive.

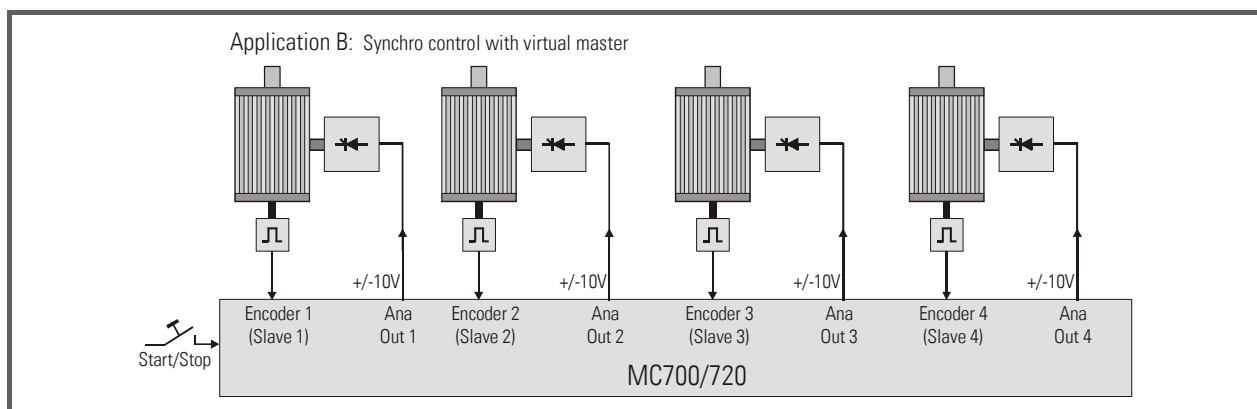
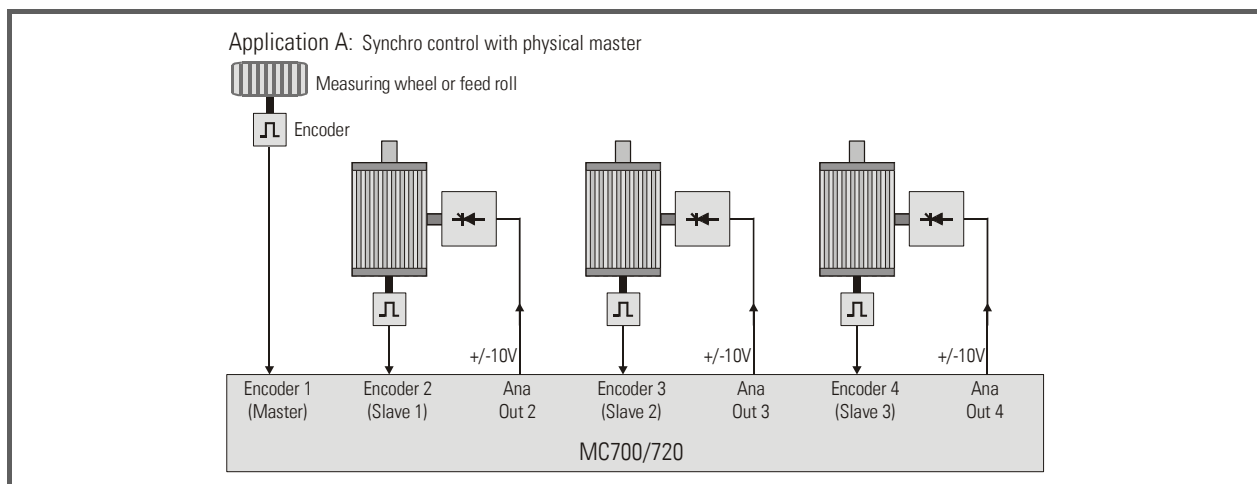

3. Who is Who? Master-Slave Assignments

Assignments of the whole Master-Slave structure can be made by the register “Master Assignment” which can be set individually for each of the 4 drives. Master can be either the Virtual Master Axis or drive 1 or drive 2, whereas drives 3 and 4 can only operate as a slave of one of these masters. It is also possible to define both, drive 1 and drive 2 as Masters at a time, and to assign slaves to each.

For cascading, the frequency of the “Encoder Output” can be used, where either the virtual master frequency or the frequency of Encoder Input 1 is available (depending on register “Frequency Select”)

The subsequent diagram explains the possible Master-Slave configurations.

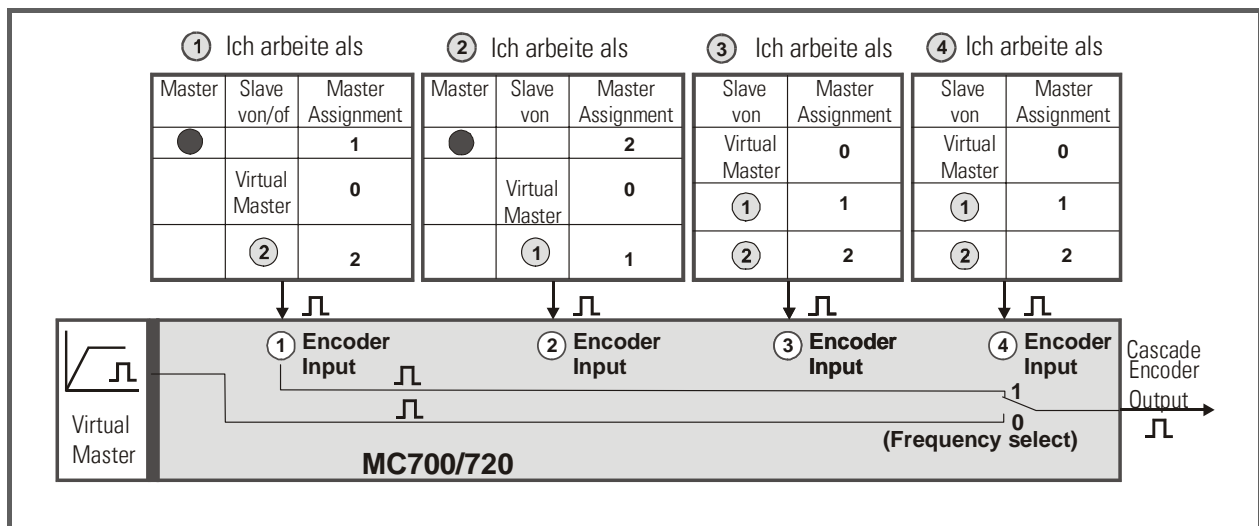

Axis which are only used as master or which are not used at all are disabled by setting parameter “Mode” to zero.

4. Pulse Scaling

For easy adaption of the synchronizer to operational and physical conditions (gear ratios, encoder resolution, roll diameters etc.), both, Master and Slave pulses can be scaled separately. The scaling factor "**Factor 1**" provides pulse scaling for the Master channel and the scaling factor "**Factor 2**" does the same for the slave. Both factors are 5 decade and operate in a range from 0.0001 to 9.9999. Setting them both to 1.0000 will result in a 1:1 speed and phase synchronization.

There are the following ways to set the factors:

- Fixed factor settings by **Laptop/PC**. This way of setting is recommended when the speed ratios are fixed and never need to be changed
- Setting by **keypad** and LCD menu (MC720 only). This way of setting is recommended with stand-alone applications, where the speed ratios need to be changed during operation.*
- By communication with a superior control system via serial **RS232/RS485** or **CAN-Bus** or **PROFIBUS**. This will be used mostly with more sophisticated applications in multi-drive systems.

Independent of the way of factor setting, the slave always changes its shaft position with respect to the master according to the following formulae:

$$S_{\text{Slave}} = \frac{\text{Fact 1}}{\text{Fact 2}} \cdot S_{\text{Master}}$$

Proportional operation

$$S_{\text{Slave}} = \frac{1}{\text{Fact 1}} \cdot \frac{1}{\text{Fact 2}} \cdot S_{\text{Master}}$$

Reciprocal operation

Proportional or **reciprocal** operation can be selected by parameter "LV-Calculation".



Remarks to previous formulae:

When **positional** and **angular synchronization** is required, we recommend setting S_{Master} and S_{Slave} to the number of pulses received from the encoders when both drives move a defined synchronous distance (e. g. one machine cycle).

When only **speed synchronization** is needed (i.e. speed errors in a range of 0.01% can be accepted), S_{Master} and S_{Slave} can also be set to the encoder frequencies at synchronous speed.

At any time, **Factor1 represents a variable** that must be used for change of speed ratios, whereas **Factor2 in general is a machine constant** to be set only one time upon commissioning.

*) Setting parameters via keypad of the MC720 is only possible during standstill of the machine! Where it is necessary to change parameter values during operation you must use serial interface or fieldbus interface.

Example for calculation of the Factors

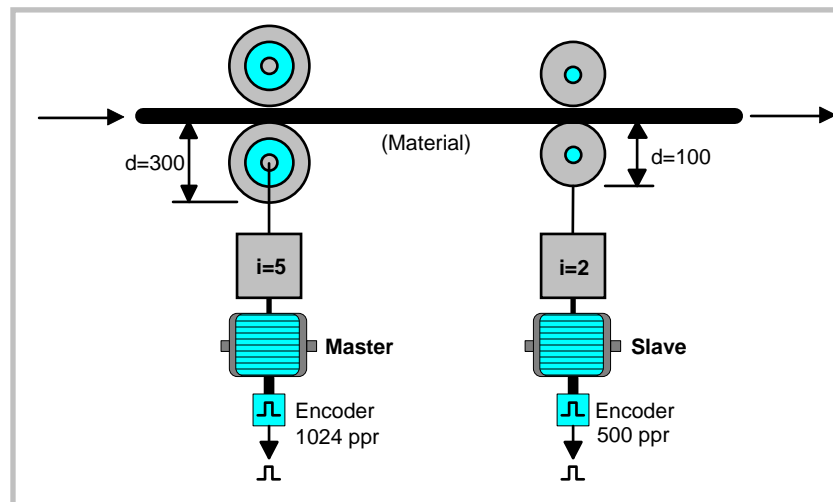

With one full revolution of the master roll, we receive $5 \times 1024 = 5120$ pulses from the master encoder. If the material must pass the roll **without** any tension, the slave roll would exactly need 3 revolutions at the same time.

So we will get $3 \times 2 \times 500 = 3000$ impulses from the slave encoder.

This means, we need **3000 slave pulses for every 5120 master pulses** to operate synchronously. We subsequently have to set up **Factor 1** and **Factor 2** so, that the relation

$$5120 \times \text{Factor1} = 3000 \times \text{Factor2}$$

becomes true. The simplest way to do this, is to set the factors exactly to the digital value of the impulse numbers from the opposite side, i.e. $\text{Factor 1} = 0.3000$ and $\text{Factor 2} = 0.5120$. This will absolutely satisfy our equation and we will also not get any cumulating errors with respect to angles and positions.

However, it might be clearer for an operator, when for a 1:1 ratio also the **Factor 1** setting would be 1.0000. This can be achieved by a proportional conversion of **Factor 2**:

$$\text{Factor2} = 5120 : 3000 = 1.706666666666\dots$$

This allows setting **Factor1** to the comprehensible value of 1.0000. However, because our settings are limited to totally 5 digits, we now will have to set $\text{Factor2} = 1.0767$. This causes an extremely small and undetectable error in speed, but this error will cumulate in terms of angle and position.



Hint 1: It is best, whenever possible, to have Factor 1 and Factor 2 in a numeric range of 0.1000 - 2.0000. This allows the BY to use the full 12 Bit resolution of all D/A converters. When, for example, the factor calculation results in figures like 4.5000 and 7.8000, it is better to set 0.4500 and 0.7800 (or 0.9000 and 1.5600 or any other proportional values within the recommended range) to ensure best operation.



Hint 2: It is best to choose the ppr number of the encoders to receive frequencies in approximately the same range on both sides. For example, it may be difficult to synchronise 100 Hz on one side with 200 kHz on the other side.



Hint 3: For the total result of pulse scaling, please observe also your edge-count settings (x1, x2 or x4) as selected under parameter "Mode Counter" for each encoder channel.

5. Ratio Change during Operation

The speed ratio can be changed at any time by changing Factor1. Changing Fact1 from 1.0000 to 2.0000 results in double slave speed (with proportional mode) or half of the slave speed (with reciprocal mode).

The **speed transition** can be sudden or soft. The slave approaches its new speed via an adjustable **ramp**.

With some applications, the **numerical value** of the speed ratio is **unknown** and the operator has to find it out by his own observation and **feeling**.

For these applications, the firmware provides a **Factor Trim Function**. Starting from the programmed basic value, Factor1 can be incremented or decremented via external pushbuttons "+" and "-". While keeping the button down, Factor 1 will increase or decrease with an adjustable searching speed.

When releasing the button, the last value will be frozen for further control of the drive speeds.

To avoid wrong operator settings, the remotely accessible range of Factor1 can be limited by the parameters Factor1-min and Factor1-max.

6. Change of Phase and Relative Position

The relative phase situation between Master and Slave is normally set by the state upon power-up or with the last Reset signal (in index modes, the index edges and the programmed phase displacement define the relative position, see chapter 7.)

During all the operation, this initial phase condition is held without errors, unless the operator uses one of three available phase adjustment facilities:

6.1. Phase Adjustment by Timer Trimming

This function, activated by the "Trim +" and "Trim -" inputs, provides a temporary higher or lower slave speed which will result in a phase displacement between the motor shafts. When releasing the trim buttons, the drives will synchronise again in their new relative position. The **differential trim speed** is adjustable and operates as a speed addition or a subtraction to the slave, **without consideration of the actual absolute speed**. This is why the trim function can also be used at standstill, to move the slave into a convenient start-up position.

As an example, the trim function is ideal for a multi color print machine, to adjust the register manually.

6.2. Phase Adjustment by External Pulse Stepping

In this operation mode, the trim inputs operate as edge triggered pulse inputs and each positive transition will displace the slave shaft position exactly by one encoder impulse (Trim+ = forward, Trim- = reverse). This function allows, for example, a PLC control to step the phase to different, **fully repeatable positions** during operation or standstill, in accordance with different product dimensions on a machine. Also is it possible to operate the controller like a **differential gearbox**, because the slave can move according to the **sum** or **difference** of two other drive speeds.

6.3. Phase Adjustment by Digital Phase Offset

The unit provides an Offset register, which can be set to a desired number of encoder pulses. In Mode 3, while input Index is held high, every rising edge at the Trim+ or Trim- input will displace the actual phase forward or backwards respectively by the number of offset pulses.

This function, as an example, can be used to create a gap between two products during the transition from a master conveyor to a slave conveyor.

7. Index Registration and Control

Index or marker pulses are used to automatically set the drives or the material into a correct relative position. It is possible to **either** use the zero pulse inputs on the encoder terminals (Z and /Z, 5V RS422) or the HTL index inputs (10...30V). Register "Index Mode" selects which of the inputs are active.

It is possible to enter the phase displacement "M" between the marker pulses by keypad or by communication, and to change it at any time, at standstill or on the fly (Register "Phase offset").

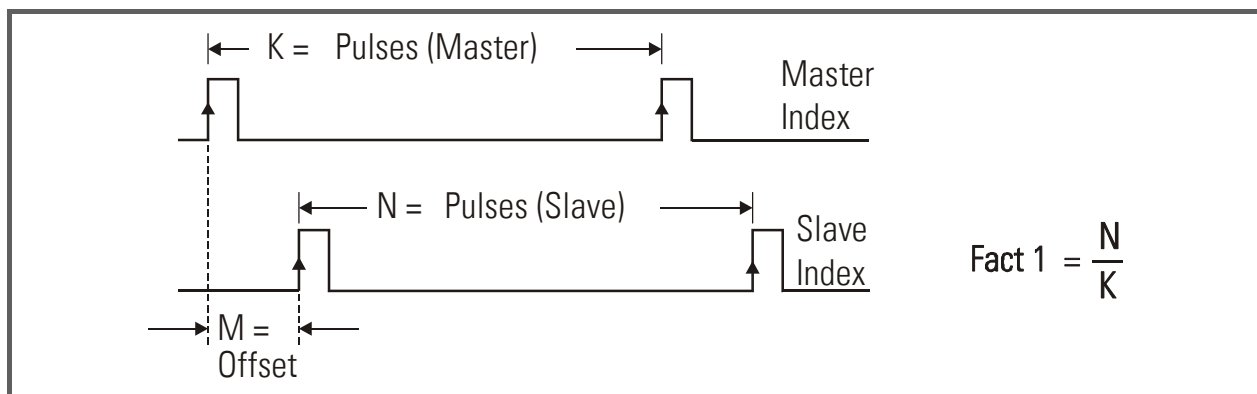

The parameter **Factor 1** is used to adapt different pulse numbers K and N on both encoders. The number of slave pulses N must be set to register "Impulse Index".

The formula in the figure above shows how to find the correct setting of Factor1.

The offset needs to be set directly as "number of slave impulses" and has a setting range from $-N/2$ to $+N/2$ which means -180° to $+180^\circ$ of displacement (0 to 360° round loop).

Between two marker signals, the drives operate in a normal digital synchronization. The master pulses are scaled with **Factor 1**, but the slave impulses count with a **fixed Factor2 = 1.0000** in Index mode.

A positive edge on the slave index input starts a phase comparison with the previous master index and a correction, if not coincident to the offset M . Additional phase adjustment, as described in the previous section, is also possible in index mode, i.e., starting from an initial phase position, the final phase can be easily tuned, by pushbuttons or PLC, if applicable. The new phase can be restored to the phase offset register by PLC by a store command.

The master index input is equipped with a programmable index divider, which, for example, allows evaluation of only every 5th marker pulse.

The slave index input is locked in a way that it is open only once after each valid master marker pulse.

Operation Mode 8 provides a fully unlocked function of the index inputs and every couple of marker impulses will cause a correction, no matter if the master leads the slave index or vice-versa.

This mode needs setting of the "Impulse Index" register to the maximum slave index distance (setting in slave encoder increments). Phase errors greater than one-half of this setting will not be corrected. In this mode, the differential speed for making phase corrections can be set by the register "Trim speed".

Mode 8 is perfectly suitable for compensation of wheel slip with large cranes (reference marks on the rails, see special description "Version B25" available on request) and to equalize different distances between products while passing from a master conveyor to a slave conveyor.

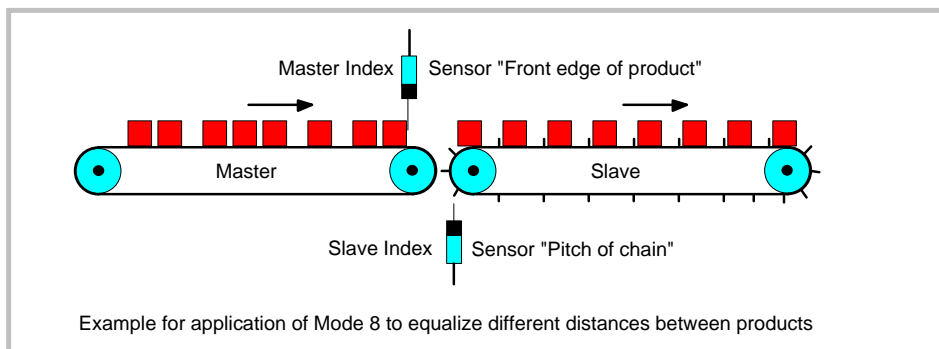

8. Download Procedure

Ex factory, all MC 700- and MC 720 controllers have loaded the MCBASE firmware, which was used for factory testing purposes.

To download an application firmware, please take the following steps:

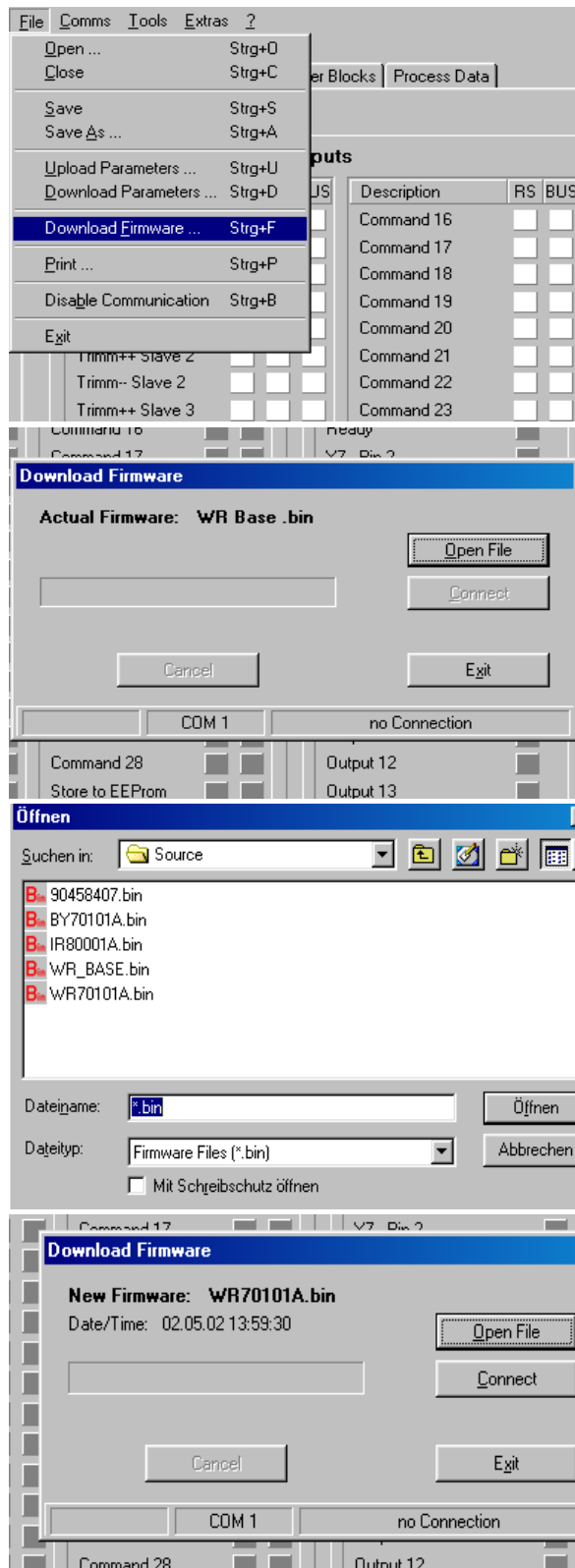

- Connect the PC to the controller, using a RS232 cable (see 3.8 of the hardware manual). Apply power to the controller and start the OS5.1 PC software. Select “Download Firmware” from the “File” menu.
- The screen now indicates the firmware which is actually loaded to the unit, in general “MCBaseXX.bin”
- Click to “Open File” and select drive and file name of the download firmware (BY701xxx.bin).
- Then click to “Connect”.

(Pictures beside use screenshots of firmware WR70101a.bin)

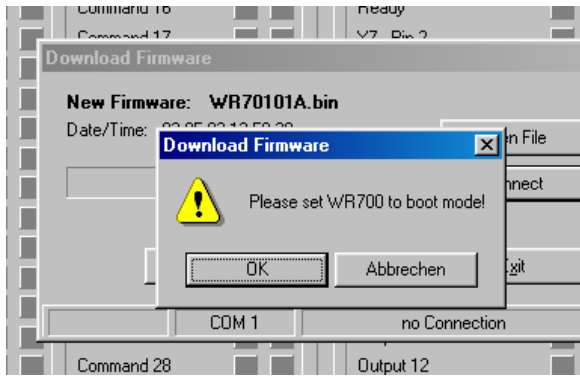

- The PC now requests you to set the controller to the "boot mode". To do this, slide the front switch from the "Run" position to the "Program" position and push the Reset button located behind the front plate, by means of a pen or a small screw driver



- Click „OK“ to start the download

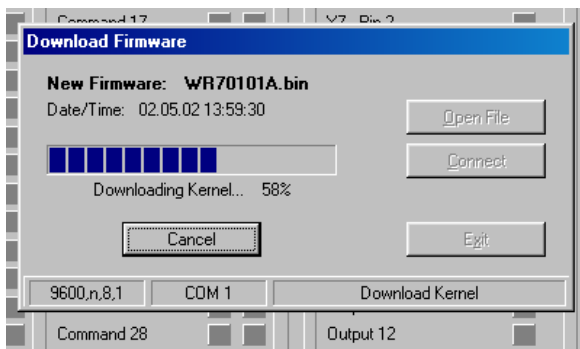

- The download uses several loading steps. The progress is displayed on the screen.

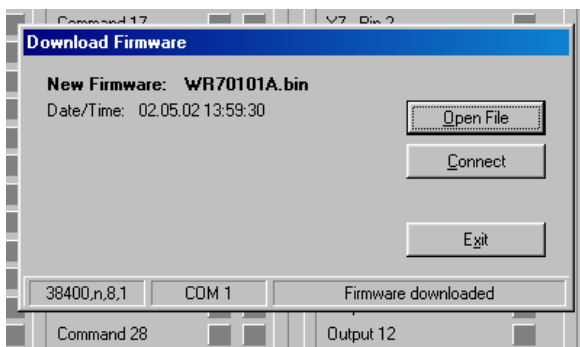

- After successful conclusion of the procedure
 - a. click to "Exit"
 - b. slide the switch back to the "Run" position
 - c. activate the Reset button for new initialization of the controller

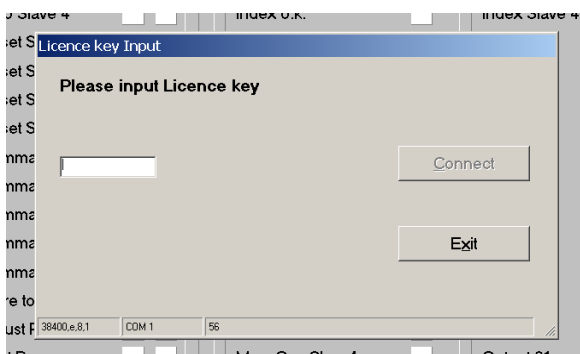

- Finally you must input the license key:
 - a. Select "Input license key" from the "File" menu
 - b. Input the license key and click to "connect"

9. How to use the operator software

The OS5 software uses a clear structure of register cards and the contents automatically adapt to the firmware of the controller.

Inputs				Outputs							
Description	X6	RS	BUS	Description	X6	RS	BUS	Description	X7,RS,BUS	Description	X7,RS,BUS
Control Enable	1	<input type="checkbox"/>	<input type="checkbox"/>	Stop Slave 1	<input type="checkbox"/>	<input type="checkbox"/>	<input type="checkbox"/>	Ready	<input checked="" type="checkbox"/>	Index Slave 1 ok	<input type="checkbox"/>
Run Slaves	2	<input type="checkbox"/>	<input type="checkbox"/>	Stop Slave 2	<input type="checkbox"/>	<input type="checkbox"/>	<input type="checkbox"/>	Alarm	<input type="checkbox"/>	Index Slave 2 ok	<input type="checkbox"/>
Run Virt. Master	3	<input type="checkbox"/>	<input type="checkbox"/>	Stop Slave 3	<input type="checkbox"/>	<input type="checkbox"/>	<input type="checkbox"/>	Maximum Correct.	<input type="checkbox"/>	Index Slave 3 ok	<input type="checkbox"/>
Reset	4	<input type="checkbox"/>	<input type="checkbox"/>	Stop Slave 4	<input type="checkbox"/>	<input type="checkbox"/>	<input type="checkbox"/>	Index o.k.	<input type="checkbox"/>	Index Slave 4 ok	<input type="checkbox"/>
Trim + Slave 1	5	<input type="checkbox"/>	<input type="checkbox"/>	Reset Slave 1	<input type="checkbox"/>	<input type="checkbox"/>	<input type="checkbox"/>	Vir.M. in motion	<input type="checkbox"/>	IndexWindow SI.1	<input type="checkbox"/>
Trim - Slave 1	6	<input type="checkbox"/>	<input type="checkbox"/>	Reset Slave 2	<input type="checkbox"/>	<input type="checkbox"/>	<input type="checkbox"/>	Mast.1 in motion	<input type="checkbox"/>	IndexWindow SI.2	<input type="checkbox"/>
Trim + Slave 2	7	<input type="checkbox"/>	<input type="checkbox"/>	Reset Slave 3	<input type="checkbox"/>	<input type="checkbox"/>	<input type="checkbox"/>	Mast.2 in motion	<input type="checkbox"/>	IndexWindow SI.3	<input type="checkbox"/>
Trim - Slave 2	8	<input type="checkbox"/>	<input type="checkbox"/>	Reset Slave 4	<input type="checkbox"/>	<input type="checkbox"/>	<input type="checkbox"/>	Error	<input type="checkbox"/>	IndexWindow SI.4	<input type="checkbox"/>
Trim + Slave 3	9	<input type="checkbox"/>	<input type="checkbox"/>	Virt.Mast.Freq.+	<input type="checkbox"/>	<input type="checkbox"/>	<input type="checkbox"/>	Alarm Slave 1	<input type="checkbox"/>	NoIndex in Win.1	<input type="checkbox"/>
Trim - Slave 3	10	<input type="checkbox"/>	<input type="checkbox"/>	Virt.Mast.Freq.-	<input type="checkbox"/>	<input type="checkbox"/>	<input type="checkbox"/>	Alarm Slave 2	<input type="checkbox"/>	NoIndex in Win.2	<input type="checkbox"/>
Trim + Slave 4	11	<input type="checkbox"/>	<input type="checkbox"/>	Virt.Mast.Dir.	<input type="checkbox"/>	<input type="checkbox"/>	<input type="checkbox"/>	Alarm Slave 3	<input type="checkbox"/>	NoIndex in Win.3	<input type="checkbox"/>
Trim - Slave 4	12	<input type="checkbox"/>	<input type="checkbox"/>	Teach Index Win.	<input type="checkbox"/>	<input type="checkbox"/>	<input type="checkbox"/>	Alarm Slave 4	<input type="checkbox"/>	NoIndex in Win.4	<input type="checkbox"/>
Index HTL Slave1	13	<input checked="" type="checkbox"/>	<input type="checkbox"/>	Command 28	<input type="checkbox"/>	<input type="checkbox"/>	<input type="checkbox"/>	Max. Cor. Slave1	<input type="checkbox"/>	Output 28	<input type="checkbox"/>
Index HTL Slave2	14	<input checked="" type="checkbox"/>	<input type="checkbox"/>	Store to EEPROM	<input type="checkbox"/>	<input type="checkbox"/>	<input type="checkbox"/>	Max. Cor. Slave2	<input type="checkbox"/>	Output 29	<input type="checkbox"/>
Index HTL Slave3	15	<input checked="" type="checkbox"/>	<input type="checkbox"/>	Adjust Program	<input type="checkbox"/>	<input type="checkbox"/>	<input type="checkbox"/>	Max. Cor. Slave3	<input type="checkbox"/>	Output 30	<input type="checkbox"/>
Index HTL Slave4	16	<input checked="" type="checkbox"/>	<input type="checkbox"/>	Test Program	<input type="checkbox"/>	<input type="checkbox"/>	<input type="checkbox"/>	Max. Cor. Slave4	<input type="checkbox"/>	Output 31	<input type="checkbox"/>

9.1. I/Os (Inputs and Outputs)

This register card shows the logical state of all digital inputs and outputs.

9.1.1. Inputs

Input signals that are in use for the current application are marked with its designation, whereas unused inputs are marked with "Command ..." only.

It is possible to assign each input signal to any of the 16 hardware inputs that are accessible via screw terminal X6 (marked "Cont.In"), please see chapter 9.1.3 for details. The number of the hardware input "In..." assigned to the input signal is displayed in column "X6".

(Please note: "In ..." input numbering is not equal to X6 connector pin numbering!)

Indicator boxes in the column marked "X6" shine blue, when the associated hardware input signal terminal X6 is HIGH, LOW state is white. Where the input signal has not been assigned to any hardware input, the box remains grey.

Indicator boxes in the columns marked "RS" shine blue, when the associated input signal has been switched on via serial link. White box means "signal off". You can switch on and off every input from your PC by clicking to the corresponding indicator box in the "RS" column.

Indicator boxes in the column "BUS" shine blue, when the associated input signal has been switched on via CAN-Bus. White box means again "signal off".

All input signals can be controlled via serial interface or CAN-Bus, independent of they are assigned to a hardware input or not.

All input signals follow a logical "OR" conjunction and the input signal is in "ON" state when at least one of the associated boxes shine blue.

Meaning and function of the input signals:

















= static operation











= dynamic operation, rising edge

Ser/Bus = Activation by serial command or by field bus only.

Control Enable 	OFF:	The whole controller and all functions are disabled. All analogue outputs are zero. All counters are hold in a Reset state. Upon transition from ON to OFF, the Slave drives decelerate to standstill via "Emergency Ramp" according to setting, before the controller goes to "disabled" state.
	ON:	The controller is enabled
Run Slave 	OFF:	The Slave drives are held in standstill (closed-loop position control). Upon change from ON to OFF the slaves ramp down to standstill according to the setting of register "Ramp".
	ON:	The Slave drives are free to follow the associated Master. Upon change from OFF to ON the slaves ramp up to synchronous speed according to the setting of register "Ramp".
Run Virt. Master 	OFF:	The virtual Master frequency is switched off (frequency = 0 Hz). Upon change from ON to OFF, the frequency ramps down from the actual value to zero (standstill), according to ramp time setting.
	ON:	The virtual Master frequency is switched on and generates the preset Master frequency. Upon change from OFF to ON, the frequency ramps up from zero (standstill) to the preset value, according to ramp time setting.
Reset 	OFF:	The differential counters and the closed-loop control of phase and position are active
	ON:	The differential counters are kept in zero state. The PI control loop therefore is switched off. The Slaves operate under open-loop conditions with no correction of angular or positional errors.

Trim + Slave1 	ON:	Forward phase trim function for Slave1 on: Slave1 changes its actual phase and position in forward direction to lead the master, by taking a temporary higher differential speed, as set at parameter "Trim Time". Special function in Mode 3 ... 6, see table at description of parameter "Mode" in chapter 9.3.1 for details.
Trim – Slave1 	ON:	Slave1 changes its actual phase and position in reverse direction to lag the master, by taking a temporary lower differential speed, as set at parameter "Trim Time". Special function in Mode 3 ... 6, see table at description of parameter "Mode" in chapter 9.3.1 for details.
Trim + Slave2		Similar to Trim+ and Trim-with Slave1, but for Slave2
Trim – Slave2		
Trim + Slave3		Similar to Trim+ and Trim-with Slave1, but for Slave3
Trim – Slave3		
Trim + Slave4		Similar to Trim+ and Trim-with Slave1, but for Slave4
Trim – Slave4		
Index HTL Slave1		HTL index input for Slave1, accepting signals from proximity switches, photocells or other sensors with 18-30 volts level. With index operation modes, the rising edge on this input will be compared to the rising edge of the associated Master index, to control the desired phase or position. Special function in Mode 3 ... 6, see table at description of parameter "Mode" in chapter 9.3.1 for details.
Index HTL Slave 2		See above, but Slave2
Index HTL Slave 3		See above, but Slave3
Index HTL Slave 4		See above, but Slave4
Stop Slave1 	OFF:	Slave1 is in synchronous operation
	ON:	Slave1 ramps down from synchronous operation to standstill and waits in a closed-loop position control
Stop Slave2 		See above, but Slave2
Stop Slave3 		See above, but Slave3
Stop Slave4 		See above, but Slave4

Reset Slave1 	OFF:	The differential counter for Slave1 and the closed-loop control of phase and position are active
	ON:	The differential counter of Slave1 is kept in zero state. The PI control loop therefore is switched off. Slave1 operates under open-loop conditions with no correction of angular or positional errors. When "Reset Slave 1" is set simultaneously with input "Teach Index Win." The index window position is taught (see below)
Reset Slave2 		See above, but Slave2
Reset Slave3 		See above, but Slave3
Reset Slave4 		See above, but Slave4
Vir.Mast.Freq.+ 	ON:	The frequency of the virtual master will be increased according to its ramp time.
Vir.Mast.Freq.- 	ON:	The frequency of the virtual master will be decreased according to its ramp time.
Vir.Mast.Dir. 	ON:	Inverts the direction of the virtual master frequency.
Teach Index Win. 	ON:	Group input to define the index position set point and to locate the index window: To teach the index window of a certain axis input "Teach Index Win." and the corresponding input "Reset Slave X" must be set simultaneously. When an index is detected while the inputs are ON, this index is selected as valid and the index window is located at this index position. When "Teach Index Win." or "Reset Slave X" are reset to OFF without an index having been detected while they were ON, the falling edge of the input (i.e. the position where it has been reset to OFF) will be taken as index position set point. This can be used to teach the index position when the corresponding axis is at standstill. (See also slave 1...4 parameter "Index Window Len.")
Command 28		-not used-
Store to EEPROM		Stores all actual parameter values to the EEPROM.
Adjust Program	Ser./ Bus	Changes the controller over from normal operation to the Adjust Program. (Control Enable must be LOW / OFF) Will be set automatically by PC operator software when you select "Adjust..." in menu "Tools".
Test Program	Ser./ Bus	Changes the controller over from normal operation to the Test Program. (Control Enable must be LOW / OFF) Will be set automatically by PC operator software when you select "Test..." in menu "Tools".

9.1.2. Outputs

Output signals that are in use for the current application are marked with a text, unused outputs are marked with "Output ..." only.

It is possible to assign each output signal to any of the 8 hardware outputs that are accessible via screw terminal X7 (marked "Cont.Out"), please see chapter 9.1.3 for details. The number of the hardware output "Out..." assigned to the output signal is displayed in the corresponding lateral indicator box.

The indicator box shines red when the corresponding output signal is on (the assigned hardware output then is HIGH), otherwise the box remains white (the assigned hardware output then is LOW).

All output signals appear on the PC screen and are accessible via serial link or CAN-Bus, independent of they are assigned to a hardware input or not.

Meaning and function of the output signals:

Ready	Indicates that the unit is ready to work after power-up, initialization and self-test. This output, however, is not a guarantee for trouble-free operation of all functions.
Alarm	Collective Alarm output for the individual alarms of Slaves 1 – 4 as described below. The output is HIGH whenever one ore several Slaves signal "Alarm".
Maximum Correct.	Collective output for the individual signals of Slaves 1 – 4 for maximum correction, as described below. The output is HIGH whenever one ore several Slaves signal "Max. Correction"
Index o.k.	Collective output for the individual "Index o.k." signals of Slaves 1 – 4 as described below. The output is HIGH only, when all of the drives that operate in index mode signal "Index o.k." at a time.
Vir. M. in motion	This output is HIGH when the actual frequency generated by the Virtual Master is higher than the standstill definition set to register "Zero-Freq.V.Master"
Mast.1 in motion	This output is HIGH when the actual frequency on the encoder input defined as "Master1" is higher than the standstill definition set to register "Zero-Freq.Master1".
Mast.2 in motion	This output is HIGH when the actual frequency on the encoder input defined as "Master2" is higher than the standstill definition set to register "Zero-Freq.Master2".
Error	This output goes HIGH when during initialization or operation an error is detected.
Alarm Slave1	Indicates that Slave1, with respect to it's Master, actually runs with a positive or negative phase error higher than the limit set under parameter „Alarm“.
Alarm Slave2	as above, but Slave2

Alarm Slave3	as above, but Slave3
Alarm Slave4	as above, but Slave4
Max.Cor. Slave1	Indicates that the maximum proportional correction signal according to register „Max.Correction“ is reached and that Slave1 potentially is out of synchronism.
Max.Cor. Slave2	as above, but Slave2
Max.Cor. Slave3	as above, but Slave3
Max.Cor. Slave4	as above, but Slave4
Index Slave 1 ok	<u>Only when Slave1 operates in Index Mode:</u> Indicates that the position of the Slave1-Index, with respect to the Master Index, is inside the tolerance window as set at parameter “Index o.k. Window”.
Index Slave 2 ok	as above, but Slave2
Index Slave 3 ok	as above, but Slave3
Index Slave 4 ok	as above, but Slave4
IndexWindow SI.1	This output is HIGH while the index window of master / slave 1 is open and detected indexes are valid. When the index window function is disabled, this output is set all the time (every index is valid).
IndexWindow SI.2	as above, but Slave2
IndexWindow SI.3	as above, but Slave3
IndexWindow SI.4	as above, but Slave4
No Index in Win.1	<u>Only when Slave1 operates in Index Mode:</u> Indicates that for an adjustable number of subsequent index windows no index has been detected within the index window (see parameter „Missing Indexes“) When the index is teached, this output is set at first and then is reset when an index has been detected during teaching or when the teaching is finished.
No Index in Win.2	as above, but Slave2

No Index in Win.3	as above, but Slave3
No Index in Win.4	as above, but Slave4
Output 28 ... Output 31	not used (reserved)

9.1.3. Assignment of Hardware Inputs and Outputs

By using register card „IO Definition“ nearly all input and output signals can be assigned to the hardware inputs and outputs, respectively:

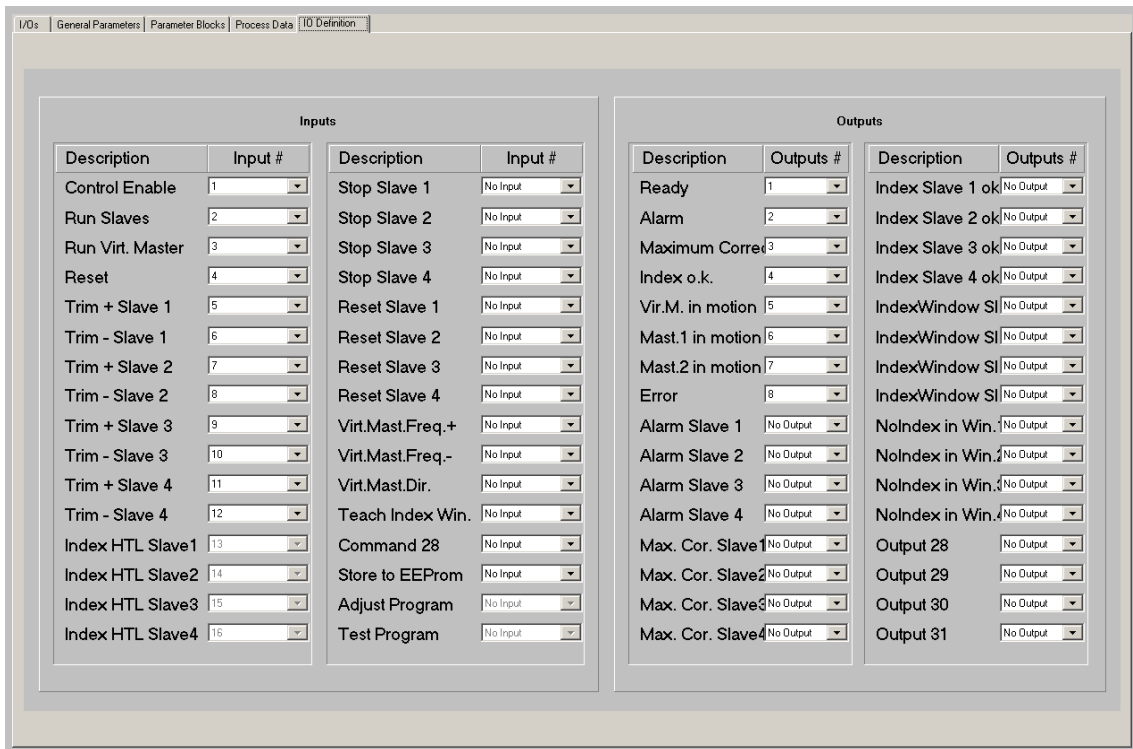

Any hardware input can be assigned to several input signals at the same time if necessary. The hardware input then switches all input functions associated in parallel.

Also any hardware output can be assigned to several output signals at the same time if necessary. Then the output signals are logical OR'd, i.e. the hardware output is set to high if any of the associated output signals is set to on.

Fixed assignments that cannot be changed (e. g. Index signals) are marked in grey color.

The input/output assignment is stored to EEPROM when leaving this register card.

9.2. General Parameters

This register card holds the essential variable settings of general nature

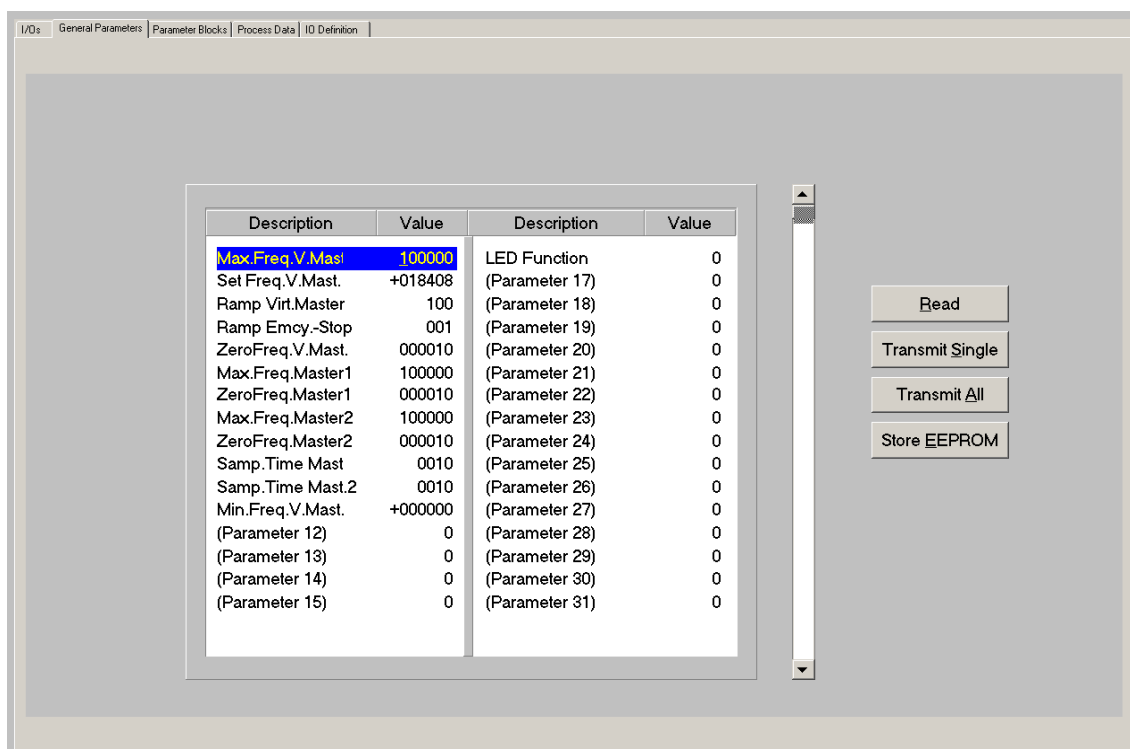

Max.Freq.V.Mast.	Sets the upper limit for all settings of the output frequency of the virtual master axis. Range 0 - 400 000 Hz This range is internally subdivided in 2048 steps
Set Freq.V.Mast.	Sets the actually desired operating speed (actual speed reference frequency of the virtual Master axis) Range -Max.Freq.V.Master ... + Max.Freq.V.Master (max. possible range -400 000 - +400 000 Hz) Internal step width Max.Freq.V.Mast. / 2048
Ramp Virt. Master	Sets the ramp time of the virtual Master axis between standstill and Max.Freq.V.Mast. (acceleration and deceleration) Range 0 – 999 sec.
Ramp Emcy.-Stop	Sets the deceleration ramp to standstill for the emergency stop condition (Input "Control Enable" goes to LOW state) Range 0 – 999 sec.
Max.Freq. Master1	<u>Only when "Encoder1" is used as a Master:</u> Setting of the expected maximum input frequency on input „Encoder1“. Range 0 - 400 000 Hz

ZeroFreq. Master1	<p><u>Only when "Encoder1" is used as a Master:</u> When the frequency on input "Encoder1" underpasses the standstill frequency defined here, output "Master1 in Motion" will switch from HIGH to LOW. Range: 0 - 400 000 Hz</p>
Max.Freq. Master2	As above, but "Encoder2"
ZeroFreq. Master2	As above, but "Encoder2"
Samp. Time Mast. 1	<p><u>Only when "Encoder1" is used as a Master:</u> Provides digital filtering of the feed forward signal generated from "Encoder 1". Range 0001 - 9999 ms. Normal setting: 1 ms</p>
Samp. Time Mast. 2	As above, but "Encoder 2"
Min.Freq.V.Mast.	<p>Sets the lower limit for all settings of the output frequency of the virtual master axis (by means of parameter "Set Freq.V.Mast" or inputs "Virt.Mast.Freq+" and "Virt.Mast.Freq-") Range 0 - 400 000 Hz</p>
(Parameter 12...15)	Not used
LED Function	<p>Sets the display mode for the LEDs 1-6 located on the connector plate: 0: The LEDs indicate the state of the hardware outputs Out1 – Out6 1-4: The LEDs show the differential error of Slave1, 2, 3 or Slave4 (see section "Function of the LED indicators")</p>
(Parameter 17...31)	Not used

9.3. Parameter Blocks

This field contains more parameters and machine specifications, separated to clearly arranged blocks.

9.3.1. Slave 1 – Slave 4

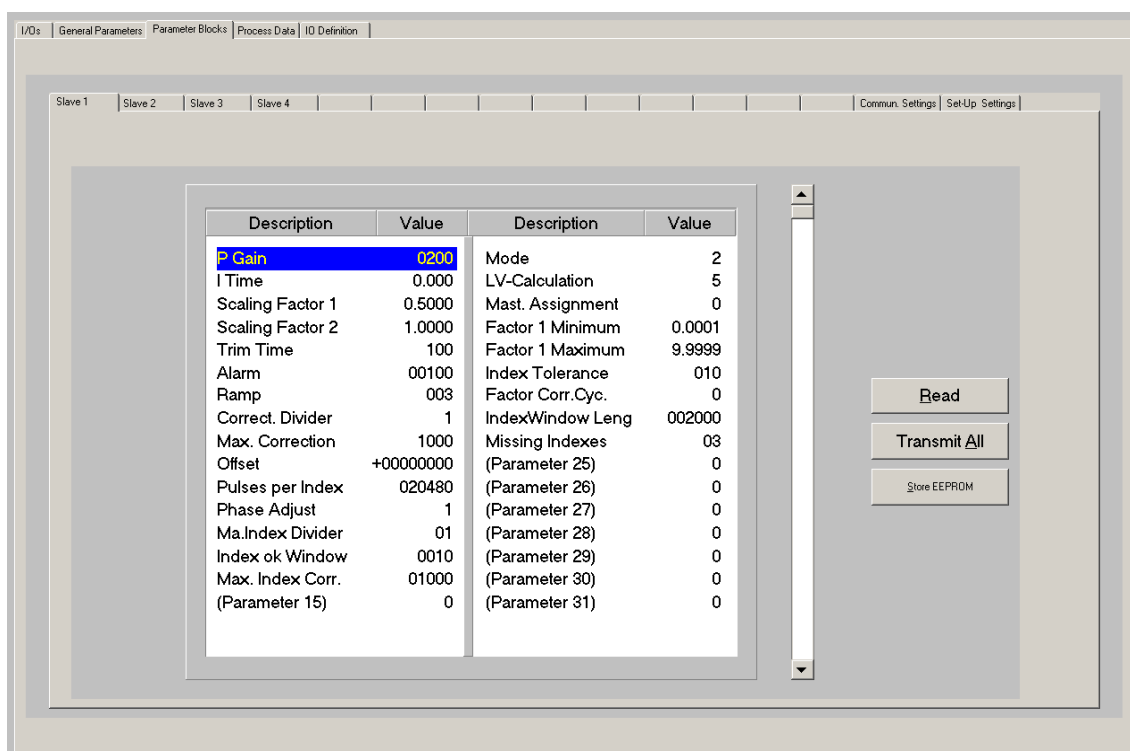

<p>P Gain</p>	<p>Proportional Gain for correction of errors of the relative position of the corresponding Slave. Range: 0 – 9999 Recommended settings: 500 ... 2500 The supplementary analogue output voltage ΔV applied to the drive depends from P-Gain and the actual angular error as follows:</p> $\Delta V = (\text{Factor1} \times \text{Count}_{\text{Master}} - \text{Factor2} \times \text{Count}_{\text{Slave}}) \times \frac{\text{P-Gain}}{1000} \times 5 \text{ mV}$
<p>I Time</p>	<p>Integration time constant (sec.) for correction of errors of the relative position of the corresponding Slave. 0.000 = no integration, proportional control only 0.001 = time constant 1 ms (extremely fast) 1.000 = time constant 1 s etc.</p>
<p>Scaling Factor 1</p>	<p>Pulse scaling factor of the associated Master drive. See section 4. of this manual.</p>
<p>Scaling Factor 2</p>	<p>Pulse scaling factor of the corresponding Slave drive. See section 4. of this manual.</p>

Trim Time	<p>a) Adjustment time for one increment of phase displacement with use of the Trim function</p> <p>b) Correction time for each increment with correction of index errors in unlocked index operation (Mode 8)</p> <p>001 = 1 ms for each increment (fast)</p> <p>999 = 999 ms for each increment (slow)</p>
Alarm	<p>Preset window for the +/- differential error to set the Alarm signal for the corresponding Slave and to switch the collective alarm output on.</p> <p>Range 1 – 32 000 encoder increments</p>
Ramp	<p>Ramp time to accelerate the corresponding Slave from standstill to maximum speed or vice-versa, when the Slave is started or stopped by commands "Run Slaves" or "Stop Slave x".</p> <p>Transition to another synchronous speed after change of Factor1 uses same slope.</p> <p>Range 001 – 999 sec.</p>
Correct. Divider	<p>Correction Divider. This provides a digital attenuation of the phase correction signal that is produced, when the drive on mechanical grounds (dead band or backlash) cannot respond. In such a case, it is not desirable to make corrections immediately. The Correction Divider provides a window for the drive "backlash", within which the controller produces no correction, and a division of the incremental error count.</p> <p>1: No window, Reaction to 1 error increment, no division.</p> <p>2: Window +/- 1 increment, division :2</p> <p>3: Window +/- 3 increments, division :4</p> <p>4: Window +/- 7 increments, division :8</p> <p>5: Window +/- 15 increments, division :16</p> <p>etc.</p>
Max. Correction	<p>Upper limitation of the correction output of the proportional control loop, i.e. with increasing angular errors the correction voltage will no more increase beyond this setting, even though the error counter will continue to count in the background.</p> <p>Range 0 – 9999 mV</p> <p>Recommended settings: higher than 1000 mV</p>
Offset	<p>Number of slave encoder pulses that the slave should displace with respect to the master, in one or the other direction.</p> <p>With modes 2 and 6, this is equivalent to the phase displacement M, in mode 3 it defines the distance of displacement</p> <p>Range: +/- 99 999 999 increments</p>
Pulses per Index	<p><u>With index operation only (Mode 2, 6 and 8):</u></p> <p>Setting of the number of encoder pulses between two index signals on the <u>Slave site</u> (see "N" in section 7.).</p> <p>Range: 0 – 999 999 increments</p>

Phase Adjust	<p><u>With index operation only (Mode 2 and 6):</u> Digital attenuation of the response upon marker pulse errors. 1: full correction with each index check, i.e. 100% 2: correction by several steps with 50% of the residual error 3: correction by several steps with 33% of the residual error 4: correction by several steps with 25% of the residual error 5: correction by several steps with 20% of the residual error etc. The setting depends on the dynamics of the drive and the maximum speed. Example: If a marker pulse arrives every 20 ms. but the drive cannot correct the largest error in 20 ms, then it will lead to instability if the next correction is executed before the previous is completed. In such a case the phase correction percentage must be reduced. See also parameter "Max. Index Corr."</p>
Ma.Index Divider	<p><u>With index operation only (Mode 2 and 6):</u> This is a programmable index divider for the master marker pulses. Range 01 – 99 It permits different numbers of marker pulses from the master and the slave. See Section 6. For the same reason as clarified above, we also recommend to use the divider with very short sequences of marker pulses, to allow the drive to stabilize before the next index correction starts.</p>
Index ok Window	<p><u>With index operation only (Mode 2 and 6):</u> This parameter sets a window, where the master and slave index pulses should be within during operation. It is possible to set the value in a range from 1 to 9999 encoder increments. It affects the signal "Index Slave ok", when master and slave index pulses are out of range, and the collective output "Index ok" goes to OFF.</p>
Max. Index Corr.	<p><u>With index operation only (Mode 2 and 6):</u> The response to registered marker pulse errors is limited to the value set here. Range from 1 to 32000 encoder increments. Works similar to parameter "Phase Adjust" but allows absolute limitation of index error correction to a level that can be handled by the corresponding drive.</p>
(Parameter 15)	Not used
Mode	<p>The Mode register sets up the operation mode and the function of the Trim inputs and the Index inputs. All modes are listed in the table below:</p>

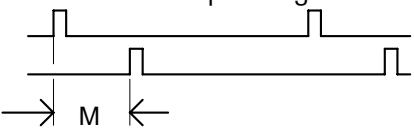
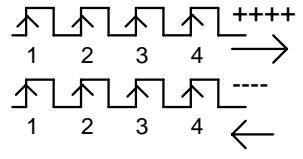
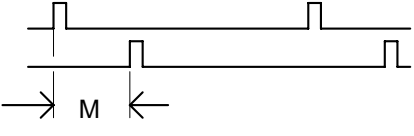
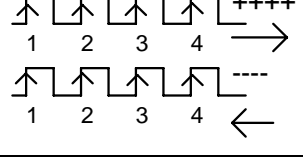
Mode	Index Inputs	Trim Inputs	Impulse Scaling
0	-Not in use-	-Not in use-	-Slave disabled-
1	-Not in use-	Change of phase by internal supplementary speed (see "Trim Time")	Factor1 : Factor2
2	Index operation with preset of the desired phasing 	Change of phase by internal supplementary speed (see "Trim Time")	Factor1 : 1.0000
3	Low:	Change of phase by internal supplementary speed (see "Trim Time")	Factor1 : Factor2
	High:	Phase displacement by offset value ahead or back.	
4	Low:	Change of phase by internal supplementary speed (see "Trim Time")	Factor1 : Factor2
	High:	Trim+: Increment Factor1 (+++) Trim-: Decrement Factor1 (---)	
5	-Not in use-	Change of phase with steps by external impulses 	Factor1 : Factor2
6	Index operation with preset of the desired phasing 	Change of phase with steps by external impulses 	Factor1 : 1.0000
7	-Same as Mode 1-		
8	Unlocked index operation with limited range of correction	Change of phase by internal supplementary speed (see "Trim Time")	Factor1 : 1.0000

LV-Calculation	<p>Sets the relationship between the impulse scaling factors (Factor1, Factor2) and the analogue speed set point. Range 5 – 8 (Settings 0 – 4 are not applicable) For most major applications, the proportional operation according to setting "5" is suitable.</p> <table border="1" data-bbox="443 434 1394 786"> <tr> <td data-bbox="451 445 512 521">5</td> <td data-bbox="520 445 1386 521"> $\text{AnaOut} = \text{Factor1} \times \frac{\text{Master-Frequency}}{\text{Max.Master-Frequency}} \times \frac{\text{Ana-Out-Gain}}{10.00} \text{ (Volt)}$ </td> </tr> <tr> <td data-bbox="451 533 512 609">6</td> <td data-bbox="520 533 1386 609"> $\text{AnaOut} = \frac{1.0000}{\text{Factor1}} \times \frac{\text{Master-Frequency}}{\text{Max.Master-Frequency}} \times \frac{\text{Ana-Out-Gain}}{10.00} \text{ (Volt)}$ </td> </tr> <tr> <td data-bbox="451 620 512 696">7</td> <td data-bbox="520 620 1386 696"> $\text{AnaOut} = \frac{\text{Factor1}}{\text{Factor2}} \times \frac{\text{Master-Frequency}}{\text{Max.Master-Frequency}} \times \frac{\text{Ana-Out-Gain}}{10.00} \text{ (Volt)}$ </td> </tr> <tr> <td data-bbox="451 707 512 784">8</td> <td data-bbox="520 707 1386 784"> $\text{AnaOut} = \frac{\text{Master-Frequency}}{\text{Max.Master-Frequency}} \times \frac{\text{Ana-Out-Gain}}{10.00} \text{ (Volt)}$ </td> </tr> </table>	5	$\text{AnaOut} = \text{Factor1} \times \frac{\text{Master-Frequency}}{\text{Max.Master-Frequency}} \times \frac{\text{Ana-Out-Gain}}{10.00} \text{ (Volt)}$	6	$\text{AnaOut} = \frac{1.0000}{\text{Factor1}} \times \frac{\text{Master-Frequency}}{\text{Max.Master-Frequency}} \times \frac{\text{Ana-Out-Gain}}{10.00} \text{ (Volt)}$	7	$\text{AnaOut} = \frac{\text{Factor1}}{\text{Factor2}} \times \frac{\text{Master-Frequency}}{\text{Max.Master-Frequency}} \times \frac{\text{Ana-Out-Gain}}{10.00} \text{ (Volt)}$	8	$\text{AnaOut} = \frac{\text{Master-Frequency}}{\text{Max.Master-Frequency}} \times \frac{\text{Ana-Out-Gain}}{10.00} \text{ (Volt)}$
5	$\text{AnaOut} = \text{Factor1} \times \frac{\text{Master-Frequency}}{\text{Max.Master-Frequency}} \times \frac{\text{Ana-Out-Gain}}{10.00} \text{ (Volt)}$								
6	$\text{AnaOut} = \frac{1.0000}{\text{Factor1}} \times \frac{\text{Master-Frequency}}{\text{Max.Master-Frequency}} \times \frac{\text{Ana-Out-Gain}}{10.00} \text{ (Volt)}$								
7	$\text{AnaOut} = \frac{\text{Factor1}}{\text{Factor2}} \times \frac{\text{Master-Frequency}}{\text{Max.Master-Frequency}} \times \frac{\text{Ana-Out-Gain}}{10.00} \text{ (Volt)}$								
8	$\text{AnaOut} = \frac{\text{Master-Frequency}}{\text{Max.Master-Frequency}} \times \frac{\text{Ana-Out-Gain}}{10.00} \text{ (Volt)}$								
Mast. Assignment	<p>Assigns a function as Master or Slave of another drive. Setting 0, 1 or 2, (see section 3. "Master-Slave Assignments")</p>								
Factor 1 Minimum	<p>Limitations of the setting range of register Factor1. Any setting out of this range will be overwritten by the appropriate minimum or maximum value.</p>								
Factor 1 Maximum	<p>Range 0.0001 – 9.9999.</p>								
Index Tolerance	<p><u>With index operation only (Mode 2, 6 and 8):</u> Threshold of deviating master index distance for automatic Factor 1 correction. Defines the max. deviation of the master index distance allowed. When the actual master index distance deviation exceeds this tolerance, then the cycle counter for automatic Factor 1 correction will be incremented (see below). Range 0...999 Increments.</p>								
Factor Corr.Cyc.	<p><u>With index operation only (Mode 2, 6 and 8):</u> Automatic correction of the Factor 1 setting of each slave by the master index distance found by measurement. Setting range 0 – 8</p> <p>0 = Factor 1 correction <i>switched off</i> 1 = Factor 1 correction after 1 cycle 2 = Factor 1 correction after 2 cycles 3 = Factor 1 correction after 4 cycles ... etc. 7 = Factor 1 correction after 64 cycles 8 = Factor 1 correction after 128 cycles</p>								

	<p>Clarification: When printing pre-printed paper or film with print marks, the material can shrink or stretch for reasons of tension, ambient temperature, humidity etc. As a result, the distance between two print marks (= master index distance) will change and no more exactly match the circumference of the printing roll. Due to the proportional control feature of the MC700/BY701 unit, this would also cause a slight displacement of the real printing position (slave index) with respect to the print mark (master index)</p> <p>The "Length Corr. Cyc." register sets a number of printing cycles (i.e. sheet lengths) where the printmark distance must be consecutively out of tolerance (see register "Index Tolerance") to always the same direction. When reached, the actual set Factor 1 of the corresponding slave is automatically overwritten by a new value calculated from the mean value of the deviating printmark distances.</p>
Index Window Len.	<p>Defines a symmetric window around the rising edge of the index signal. The index is supposed to appear inside this window and signals outside the window will not trigger the index registration.</p> <p>The position of the window is determined by inputs "Teach Index Win." and "Reset Slave ...".</p> <p>Range 0-999 999 increments. Setting 0 disables index window function, then every index will be detected.</p> <p>Clarification:</p> <p>When using print marks as index signals, many times you can find several marks on one size of the sheet, and only one of these marks is valid for index registration. The unit can automatically blank out the other marks by defining an index window around the position of the valid printmark.</p> <p>To set the correct position of the index window, set inputs "Teach Index Win." and "Reset Slave ..." to high when the valid print mark is close to the print mark sensor, but is not yet sensed. Move the line slowly until the sensor detects the mark and switches from low to high (rising edge required!). Set inputs "Teach Index Win." and "Reset Slave ..." back to low state before the sensor generates the next rising edge from the following mark. This stores the position of the valid print mark and the unit will not trigger to the other marks between.</p>
Missing Indexes	<p>Monitoring of indexes within the index window:</p> <p>This register sets the number of subsequent index windows without index (i.e. where the index is missing) until output "No Index in Win." is set.</p> <p>Range 0 – 99. Setting 0 disables the index monitoring.</p>
(Parameter 25...31)	Not used

9.3.2. Communication settings:

This register card sets the communication parameters for the CAN interface and the serial link.

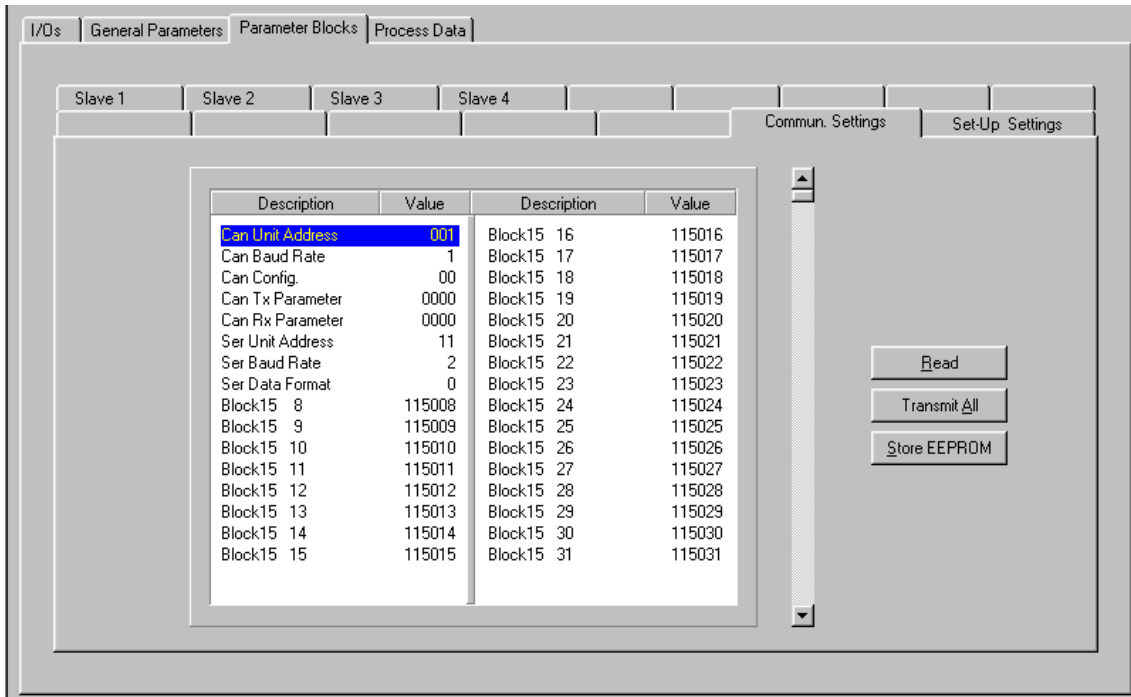

Settings and operation of the CANopen interface are explained separately in the manual **CI700**, which is available on our homepage or on our CD-ROM

The serial link uses the following parameters:

Ser. Unit Address	Serial unit address. Range 11 ... 99. Address numbers containing zeros like 01, 02, 03, ..., 10, 20, etc. are not permitted because these are reserved for broadcast messages (collective addressing of several units) Factory default address is always 11.
Ser. Baud Rate	0: 38400 bps 1: 19200 bps 2: 9600 bps 3: 4800 bps 4: 2400 bps Factory setting: 2

Ser. Data Format	Setting	Data bits	Parity	Stop bits
	0	7	even	1
	1	7	even	2
	2	7	odd	1
	3	7	odd	2
	4	7	none	1
	5	7	none	2
	6	8	even	1
	7	8	odd	1
	8	8	none	1
	9	8	none	2
Factory setting: 0				

9.3.3. Setup Settings:

These settings define all important hardware properties of inputs and outputs of the MC700 controller. You must only make settings for these functions that are really used and wired with this application.

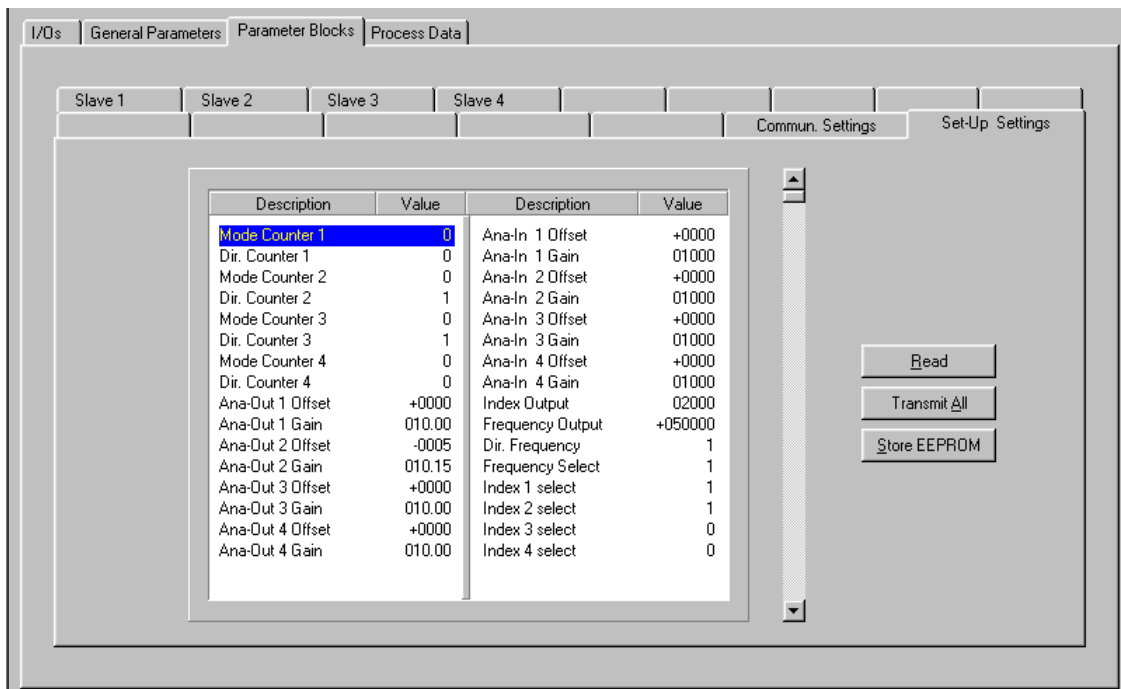

Mode Counter 1–4	Determines the number of edges counted from the four incremental encoder inputs: $0 = x1$, $1 = x2$, $2 = x4$
Dir. Counter 1–4	Assigns a counting direction (up / down) to the corresponding encoder input, depending on the quadrature A/B phase displacement. These parameters are found out and set best in the Test menu or the Adjust menu

Ana-Out Offset 1-4	Sets the zero position of the corresponding analogue output. This parameter uses a numeric range from -2047 ... 0000 ... +2047 corresponding to --100% ... 0% ... +100% full-scale output. The normal setting is "0"
Ana-Out Gain 1-4	Sets the full-scale output of the corresponding analogue output, directly in volts. These parameters are found out and set best in the Test menu or the Adjust menu 0 – 10.00 means 0 – 10 volts or 20 mA output
Ana-In 1-4 Offset	Not used with this application
Ana-In 1-4 Gain	
Index Output	Index distance of Virtual Master: Generates a virtual marker pulse every xxxxx virtual encoder pulses. With MC700 hardware version 720WR15 and later the virtual marker pulse can be used as master index. Range 0 – 99 999
Frequency Output	-For factory testing purpose only-
Dir. Frequency	Sets the counting direction of the virtual master frequency: 0 = forward, 1 = reverse
Frequency Select	Selects the source of the output frequency appearing at connector „Encoder Output“ for cascading and other purpose: 0: The output frequency is the same signal as applied to input "Encoder1" 1: The output frequency is the signal generated by the virtual master axis
Index 1 select	<u>Source of index signal Slave1 / Master 1:</u> 0: Index control OFF 1: TTL-Index Z, /Z from pins 7 und 6 of input „Encoder1“ 2: HTL-Index from Input „In13“ on the screw terminal strip
Index 2 select	<u>Source of index signal Slave2 / Master 2:</u> 0: Index control OFF 1: TTL-Index Z, /Z from pins 7 und 6 of input „Encoder2“ 2: HTL-Index from Input „In14“ on the screw terminal strip
Index 3 select	<u>Source of index signal Slave3:</u> 0: Index control OFF 1: TTL-Index Z, /Z from pins 7 und 6 of input „Encoder3“ 2: HTL-Index from Input „In15“ on the screw terminal strip
Index 4 select	<u>Source of index signal Slave4:</u> 0: Index control OFF 1: TTL-Index Z, /Z from pins 7 und 6 of input „Encoder4“ 2: HTL-Index from Input „In16“ on the screw terminal strip

9.4. Process data (actual values)

You can follow all real process data assigned to this firmware, when you open the register card "Process data". These actual values are updated continuously.

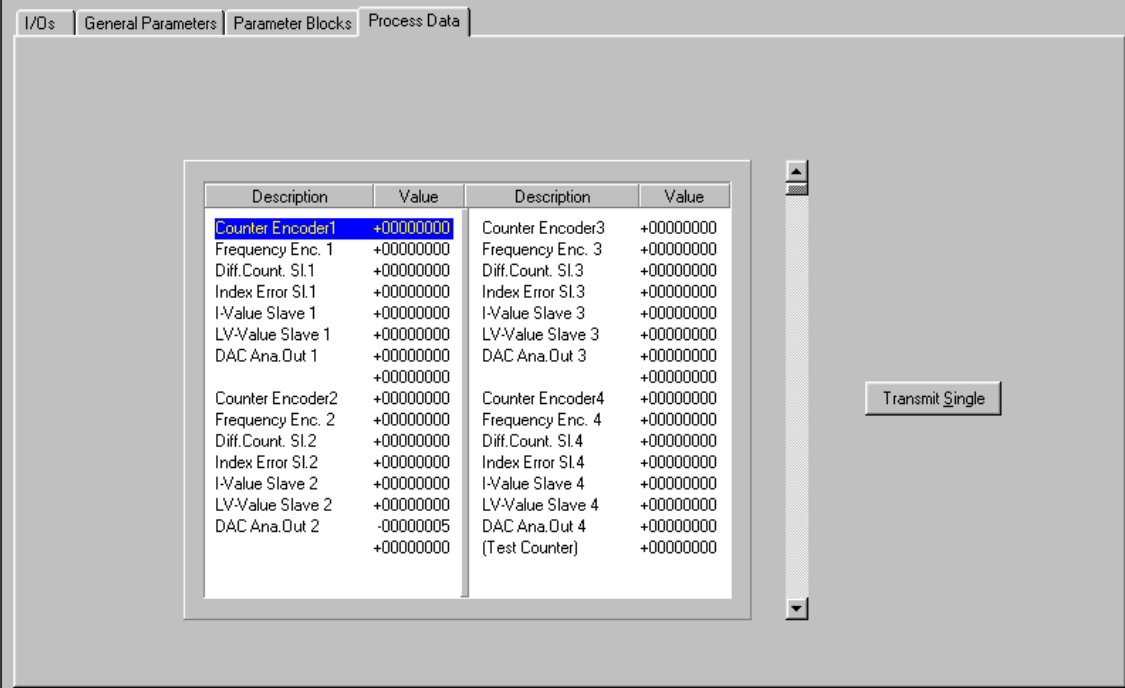

The screenshot shows a software interface with a tabbed menu at the top containing 'I/Os', 'General Parameters', 'Parameter Blocks', and 'Process Data'. The 'Process Data' tab is active, displaying a table with two columns: 'Description' and 'Value'. The table is divided into two sections by a vertical line. The first section contains 10 rows of data, and the second section contains 10 rows. The first row in the first section, 'Counter Encoder1', is highlighted in blue. To the right of the table is a vertical scrollbar and a 'Transmit_Single' button.

Description	Value	Description	Value
Counter Encoder1	+00000000	Counter Encoder3	+00000000
Frequency Enc. 1	+00000000	Frequency Enc. 3	+00000000
Diff.Count. Sl.1	+00000000	Diff.Count. Sl.3	+00000000
Index Error Sl.1	+00000000	Index Error Sl.3	+00000000
I-Value Slave 1	+00000000	I-Value Slave 3	+00000000
LV-Value Slave 1	+00000000	LV-Value Slave 3	+00000000
DAC Ana.Out 1	+00000000	DAC Ana.Out 3	+00000000
	+00000000		+00000000
Counter Encoder2	+00000000	Counter Encoder4	+00000000
Frequency Enc. 2	+00000000	Frequency Enc. 4	+00000000
Diff.Count. Sl.2	+00000000	Diff.Count. Sl.4	+00000000
Index Error Sl.2	+00000000	Index Error Sl.4	+00000000
I-Value Slave 2	+00000000	I-Value Slave 4	+00000000
LV-Value Slave 2	+00000000	LV-Value Slave 4	+00000000
DAC Ana.Out 2	-00000005	DAC Ana.Out 4	+00000000
	+00000000	(Test Counter)	+00000000

You find a description of the actual process data values in the corresponding table of chapter 14.

10. Function of the LED indicators

There are 6 red LEDs mounted to the connector plate of the unit, for display of the actual positional error of the slave position with regard to the scheduled position. The LEDs are scaled in "encoder increments" and the update cycle is less than one millisecond. Therefore, this simple means of error display provides good information about the dynamic performance of the control loop.

For assignment to one of the Slaves see parameter "LED-Function".

With hardware version MC720, also the front LEDs operate in a similar way.

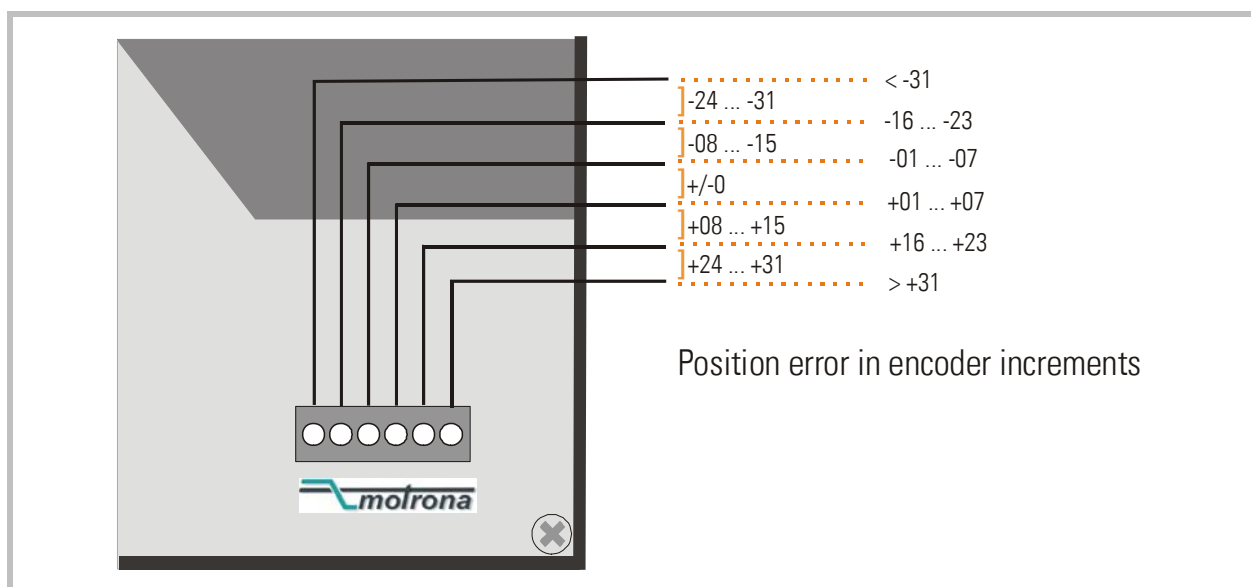

11. Error messages

Upon detection of an error, the output "Error" switches to HIGH. Where your PC with OS50 software is online, you can read the error message at the bottom of the screen.

Error 00: DPRAM Error	An error was detected when checking the internal Dual Port RAM. The DPRAM is used for data exchange with the CAN network, therefore no CAN communication will be possible while this error exists. This error appears in the display only but will not stop control. It can only be reset by cycling the power supply.
Error 01: Power Low Error	This error is set if the power supply voltage falls below the minimum of about 17 V. The controller is disabled while this error exists. The error is reset automatically when the power supply voltage recovers and exceeds the minimum threshold.
Error 02 ... 31	Not used

12. Steps for Commissioning

For set-up and commissioning of all drives, the „Adjust“ menu is available under „Tools“ in the main menu of the screen. To start the Adjust menu, input “Control Enable” must first be LOW. **At this time, all drives must be adjusted to a proper and stable operation over the full speed range. Slave drives need a maximum of dynamics and response (set ramps to zero, switch of any integral or differential component of the internal speed control loop, operate the drive with proportional speed control only, with the proportional Gain as high as possible).**

Before you start the Adjust menu, make sure that all parameters on the required register cards are set correctly. Where you find the possibility for integration, please switch it off for the first steps (set “I-Time” to 0)

The Adjust Program is used to set the directions of rotation of the encoders and to adjust the analogue output levels and the Proportional Gain. Also, the screen displays the actual encoder frequency and the number of increments between two marker pulses (Z-Distance, with Index operation only).

Please note: For the adjustment procedure, all Slaves use always the virtual master axis as a reference, no matter to which Master it is associated.

12.1. Preparations

Register cards “Adjust Slave 1” to “Adjust Slave 4” select the encoders connected to the corresponding input, independent of their assignment to be Master or Slave (all encoders are temporary treated as Slaves in this menu).

When the corresponding input is set for Master function, the motion requested for the adjustment procedure must be made by hand or by applying a remote speed reference voltage to the drive.

When the corresponding input is set for Slave function, the controller will generate the speed reference voltage to move the drive. For this, the following settings must be made:

- **Frequency Preset:** Set the virtual speed that you would like to use for adjusting the Slaves. This setting is directly in Hz of Master encoder frequency and the default value is 10% of the maximum frequency you have set before (= recommended speed for adjustments).
- **Ramp Time:** This ramp time is used for all acceleration and deceleration of Slaves during the adjust procedure.
- **P-Gain:** An initial setting of 500 is recommended.
- **Ana-Out-Gain:** Start with the default value of 1000, which corresponds to a maximum analogue output of 10.00 volts.

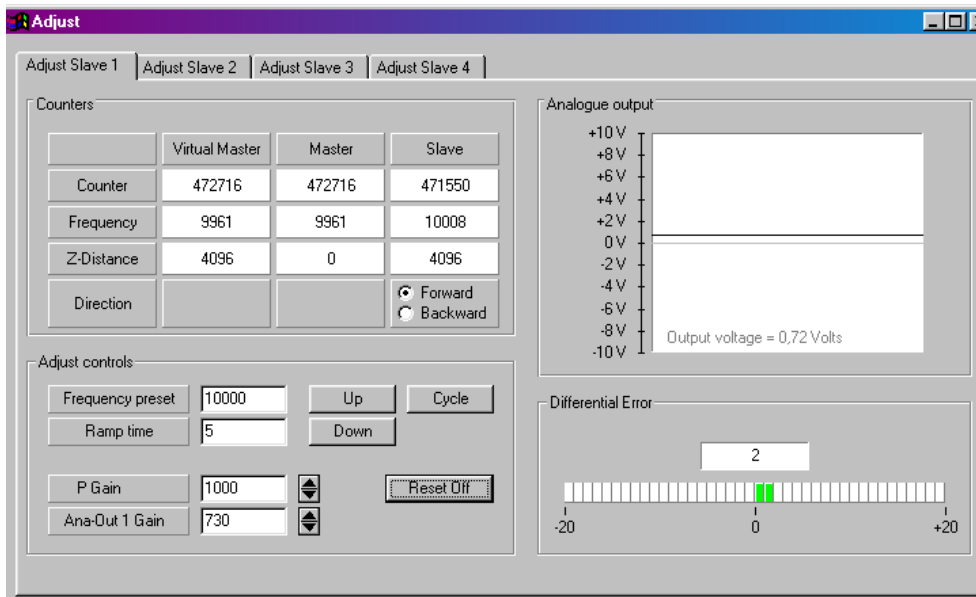

12.2. Direction of Rotation

This definition must be met for every encoder connected to the unit, no matter if it operates as a Master or a Slave.

With Master encoders:

- Move your Master encoder into **forward** direction (manually or by means of a remote speed signal to the Master drive)
- Observe the counter in the "**Slave**" column (see arrow). It must **count up** (increment)! Where you find it counts down, please click to the unchecked direction box of the Slave column (Forward or Reverse) to change the direction.

With Slave encoders:

- Click to the "Up" key to start the slave drive. The Slave will ramp up to the speed according to your previous ramp and frequency settings. It is a must that the Counter in the "**Slave**" column **counts up** (increments). Where you find it **counts down** (decrements), please click to the other direction box (Forward or Reverse) to force it to upwards count.
- Once it counts up, click to the "Down" key to stop the drive again. The definition of direction of rotation has been stored to the unit now.

Only when the slave counter counts up while the according axis moves forward, the definition of the Encoder direction is correct!

12.3. Tuning the Analogue Output

(to be accomplished with Slaves only)

- Start the drive again by clicking "Up". Now switch the Reset to OFF by clicking to the Reset key showing actually "Reset On". This activates the closed loop control.
- Observe the color bar and the differential counter in the field "Differential Error". There are two possibilities:
 - a) The bar graph moves to the right and the counter counts up (+):
This indicates that the analogue output is too low. Please increase the setting of "Ana-Out Gain" by overtyping the figures or by scrolling up with the arrow key.
 - b) The bar graph moves to the left and the counter counts down (-):
This indicates that the analogue output is too high. Please decrease the setting of "Ana-Out Gain" by overtyping the figures or by scrolling down with the arrow key. "Ana-Out Gain" is set correctly when the bar graph remains in its centre position and the differential counter swings around zero (i.e. +/-8)

Hint: You can reset the differential counter to zero at any time between, by cycling the "Reset" command.

12.4. Setting of the proportional Gain

The setting of register "P-Gain" determines how strong the controller responds to position and speed errors of the drive. In principle, this setting therefore should be as high as possible. However, depending on dynamics and inertia of the whole system, too high gain values will produce stability problems.

Please try to increase the setting of P-Gain from 500 to 1000, 1500, 2000 etc. However, as soon as you find unsteady operation, noise or oscillation, you must reduce the setting again correspondingly.

We also recommend using the automatic "Cycle" function for observations of the stability. When clicking to this key, the drive will continuously ramp up and down while you can check the color bar and the differential counter for stable operation.

Once you have done these steps, you can leave the Adjust menu and your machine is ready for operation.

12.5. Hints for final operation

- **Integrator:** When, for stability reasons, you needed to keep your "Gain Correction" value low, any important non linearity in your drive system could cause changing phase errors* with changing speeds or loads (e.g. color bar deviates to right at low speed, stays in centre at medium speed and deviates to left at maximum, speed).

Where your differential counter remains in an acceptable range around zero (e.g. -5....0....+5), there is no need to use the Integrator and you can leave the "Integration Time"" setting at 000.

Where you feel your phase accuracy must become better, set "Integration Time" to 50....40....30 20....10 or even lower. The Integrator will move the phase error always into a +/- 6 increments error window and the lower the setting, the faster the speed of compensation. Too low settings (= too high integration speeds) will however result in oscillation.

With Index operation, the Integrator is automatically switched off, as the marker pulses will compensate for phase errors.

- **Correction Divider:** Where you find your color bar oscillates quickly around zero over several fields, this indicates your encoder resolution is high with respect to mechanical clearance and backlash. Set the correction divider to 2 or 3 to get more stable operation.

* Please note that a deviation of the color bar does not indicate a speed error at all, unless the differential counter shows figures outside a +/- 1024 error increment range. Inside this range, the speed is error-free and deviations only refer to a constant number of encoder increments that the Master leads or lags the Slave.

13. Hints for controller type MC720 with integrated operator terminal

Controllers type MC720 are equipped with a keypad and a LCD display, providing all entries and operations of the controller.

13.1. Setting of parameters and registers

All the menu structure of the LCD display is fully similar to the structure of the register cards with the PC software. To start the menu, press **F1**. Select the menus and sub-menus by using the arrow keys and. Confirm your choice by Enter. With all further actions, **Enter** will go **forward** and **PRG** go **back** in the menu structure.

For all operations, just follow the hints given on the LCD menu. Once you have studied section 9 of this manual, all keypad and LCD operations will be self-explaining.

Actually, the keyboard of MC720 allows parameter changes only in the Stop state (input "Run Slaves" = LOW).

You can however change all settings "on the fly" when using serial or field bus communication.

13.2. Display of actual process values

During normal production, you can use the LCD for display of interesting actual values and process data. The PC operator software allows you to define, to scale these values, and to add text comments according to your choice.

The menu "LCD Definitions" can be found under "Extras" of the headline menu.

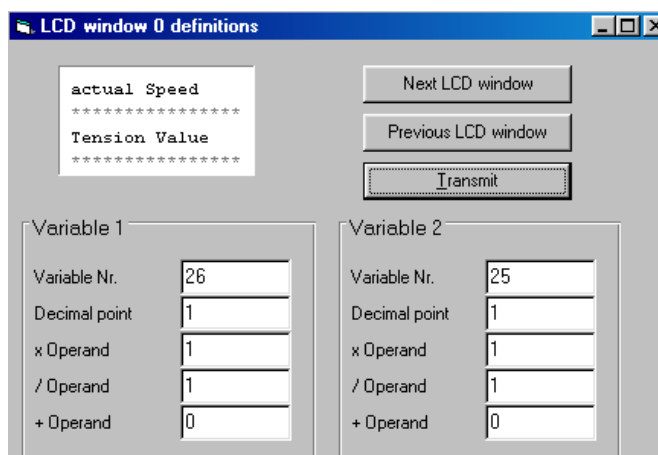

- There are totally four LCD windows accessible (0 – 3) and the actual window number appears in the blue headline. To change from one window to another, use the keys "Next LCD window" or "Previous LCD window".

- Each window allows displaying two actual values with two text comments. The line with asterisks ********* serves as space holder for the values displayed later on the LCD. When you click to the text line, you can edit the text comments according to your need (max. 16 characters for each text comment)
- **Variable Nr:** Defines which of all available values should appear in the display. Please choose one of the 32 available actual values (00 – 31) as shown on the screenshot “Process Data” in chapter 9.4 and in the corresponding table in chapter 14.
- **Decimal point:** Defines the position where a decimal point should appear on the LCD display (0=no decimal point).
- **xOperand, /Operand, +Operand:** These 5-decade operands can be used to change the scaling of your display value to the desired engineering units.

$$\text{LCD display} = \text{register value} \times \frac{\text{xOperand}}{\text{/Operand}} + \text{+/-Operand}$$

When you have entered your specifications to a window, click to „Transmit“ to store your definitions to the controller.

In production state, you can use the key F2 to switch from one of the four windows to the next and to read the actual values you have assigned.

Key F1:	Enter into the menu for setting or modifying parameters
Key F2:	Cycle from one window to next to read the actual values

14. Parameter tables

General Parameters

Description	Unit	Serial Code		Minimum	Maximum	Default
		(Hex)	(Dec)			
Max.Freq.V.Mast.	Hz	0000	0	1	400000	100000
Set Freq.V.Mast	Hz	0001	1	-400000	+400000	10000
Ramp Virt. Master	s	0002	2	1	999	3
Ramp Emcy. Stop	s	0003	3	0	999	1
Zero Freq. V.Mast.	Hz	0004	4	0	400000	1
Max.Freq. Master1	Hz	0005	5	1	400000	100000
Zero.Freq. Master1	Hz	0006	6	0	400000	1
Max.Freq. Master2	Hz	0007	7	1	400000	100000
Zero.Freq. Master2	Hz	0008	8	0	400000	1
Min.Freq.V.Mast.	Hz	0009	9	-400000	400000	0
...	
LED Function		0010	16	0	4	0
...				
(General 31)		001F	31			

Parameter Blocks: Slave 1...4

Description	Unit	Serial Code								Minimum	Maximum	Default
		Slave 1		Slave 2		Slave 3		Slave 4				
		(Hex)	(Dec)	(Hex)	(Dec)	(Hex)	(Dec)	(Hex)	(Dec)			
P-Gain		0100	256	0120	288	0140	320	0160	352	0	9999	1000
I Time	s	0101	257	0121	289	0141	321	0161	353	0	9999	0
Scaling Factor 1		0102	258	0122	290	0142	322	0162	354	0.0001	9.9999	1.0000
Scaling Factor 2		0103	259	0123	291	0143	323	0163	355	0.0001	9.9999	1.0000
Trim Time	ms/ inc.	0104	260	0124	292	0144	324	0164	356	0	999	100
Alarm	incr.	0105	261	0125	293	0145	325	0165	357	0	320000	100
Ramp	s	0106	262	0126	294	0146	326	0166	358	0	999	0
Correct. Divider		0107	263	0127	295	0147	327	0167	359	1	9	1
Max. Correction	mV	0108	264	0128	296	0148	328	0168	360	1	9999	9999
Offset	incr.	0109	265	0129	297	0149	329	0169	361	-99999999	+99999999	0
Pulses per Index	incr.	010A	266	012A	298	014A	330	016A	362	0	999999	1000
Phase Adjust		010B	267	012B	299	014B	331	016B	363	1	9	1
Ma.Index Divider		010C	268	012C	300	014C	332	016C	364	1	99	1
Index ok Window	incr.	010D	269	012D	301	014D	333	016D	365	0	9999	10
Max. Index Corr.	Incr.	010E	270	012E	302	014E	334	016E	366	1	32000	32000
(Parameter 15)		010F	271	012F	303	014F	335	016F	367			
Mode		0110	272	0130	304	0150	336	0170	368	0	8	1
LV-Calculation		0111	273	0131	305	0151	337	0171	369	5	8	5
Mast. Assignment		0112	274	0132	306	0152	338	0172	370	0	2	0
Factor1 Minimum		0113	275	0133	307	0153	339	0173	371	0.0001	9.9999	1.0000
Factor1 Maximum		0114	276	0134	308	0154	340	0174	372	0.0001	9.9999	1.0000
Index Tolerance	Incr.	0115	277	0135	309	0155	341	0175	373	0	999	10
Factor Corr.Cyc.		0116	278	0136	310	0156	342	0176	374	0	8	0
Index Window Len.	Incr.	0117	279	0136	311	0157	343	0177	375	0	999999	0
Missing Indexes		0118	280	0137	312	0158	344	0178	376	0	99	0
(Parameter 25)		0119	281	0138	313	0159	345	0179	377			
...				
(Parameter 31)		011F	287	013F	319	015F	351	017F	383			

Communication Settings

Description	Unit	Serial Code		Minimum	Maximum	Default
		(Hex)	(Dec)			
Can Unit Address		02C0	704	001	127	001
Can Baud Rate		02C1	705	0	7	1
Can Config.		02C2	706	000	255	000
Can Tx Par		02C3	707	000	255	000
Can Rx Par		02C4	708	000	255	000
Ser Unit Address		02C5	709	11	99	11
Ser Baud Rate		02C6	710	0	4	2
Ser Data Format		02C7	711	0	9	0
(Block 15 8)		02C8	712			
...				
(Block 15 31)		02DF	735			

Setup-Up Settings

Description	Unit	Serial Code		Minimum	Maximum	Default
		(Hex)	(Dec)			
Mode Counter 1		02E0	736	0	2	0
Dir. Counter 1		02E1	737	0	1	1
Mode Counter 2		02E2	738	0	2	0
Dir. Counter 2		02E3	739	0	1	1
Mode Counter 3		02E4	740	0	2	0
Dir. Counter 3		02E5	741	0	1	1
Mode Counter 4		02E6	742	0	2	0
Dir. Counter 4		02E7	743	0	1	1
Ana-Out Offset 1		02E8	744	-2047	+2047	0
Ana-Out Gain 1		02E9	745	000.00	320.00	1000
Ana-Out Offset 2		02EA	746	-2047	+2047	0
Ana-Out Gain 2		02EB	747	000.00	320.00	1000
Ana-Out Offset 3		02EC	748	-2047	+2047	0
Ana-Out Gain 3		02ED	749	000.00	320.00	1000
Ana-Out Offset 4		02EE	750	-2047	+2047	0
Ana-Out Gain 4		02EF	751	000.00	320.00	1000
Ana-In 1 Offset*		02F0	752	-9999	+9999	0
...				
Ana-In 4 Gain*		02F7	759	0	99999	010.00
Index Output		02F8	760	2	65500	2000
Frequency Output		02F9	761	-500000	+500000	50000
Dir. Frequency		02FA	762	0	1	1
Frequency Select		02FB	763	0	1	1
Index 1 select		02FC	764	0	2	0
Index 2 select		02FD	765	0	2	0
Index 3 select		02FE	766	0	2	0
Index 4 select		02FF	767	0	2	0

*) Not used for this application

Process Data (Actual Values)

No.	Description	Unit	Serial Code		Explanation:
			(Hex)	(Dec)	
0	Counter Encoder 1	Inc.	0800	2048	Counter for pulses of Encoder 1
1	Frequency Enc. 1	Hz	0801	2049	Frequency of Encoder 1
2	Diff.Count. SI.1	Inc.	0802	2050	Differential Error of Slave 1
3	Index Error SI.1	Inc.	0803	2051	Index Error of Slave 1
4	I-Value Slave 1		0804	2052	Integration value of Slave 1
5	LV-Value Slave 1		0805	2053	Feed Forward Value of Slave 1
6	DAC Ana.Out 1	5 mV	0806	2054	Voltage of Analogue Output 1
7			0807	2055	
8	Counter Encoder 2	Inc.	0808	2056	Counter for pulses of Encoder 2
9	Frequency Enc. 2	Hz	0809	2057	Frequency of Encoder 2
10	Diff.Count. SI.2	Inc.	080A	2058	Differential Error of Slave 2
11	Index Error SI.2	Inc.	080B	2059	Index Error of Slave 2
12	I-Value Slave 2		080C	2060	Integration value of Slave 2
13	LV-Value Slave 2		080D	2061	Feed Forward Value of Slave 2
14	DAC Ana.Out 2	5 mV	080E	2062	Voltage of Analogue Output 2
15			080F	2063	
16	Counter Encoder 3	Inc.	0810	2064	Counter for pulses of Encoder 3
17	Frequency Enc. 3	Hz	0811	2065	Frequency of Encoder 3
18	Diff.Count. SI.3	Inc.	0812	2066	Differential Error of Slave 3
19	Index Error SI.3	Inc.	0813	2067	Index Error of Slave 3
20	I-Value Slave 3		0814	2068	Integration value of Slave 3
21	LV-Value Slave 3		0815	2069	Feed Forward Value of Slave 3
22	DAC Ana.Out 3	5 mV	0816	2070	Voltage of Analogue Output 3
23			0817	2071	
24	Counter Encoder 4	Inc.	0818	2072	Counter for pulses of Encoder 4
25	Frequency Enc. 4	Hz	0819	2073	Frequency of Encoder 4
26	Diff.Count. SI.4	Inc.	081A	2074	Differential Error of Slave 4
27	Index Error SI.4	Inc.	081B	2075	Index Error of Slave 4
28	I-Value Slave 4		081C	2076	Integration value of Slave 4
29	LV-Value Slave 4		081D	2077	Feed Forward Value of Slave 4
30	DAC Ana.Out 4	5 mV	081E	2078	Voltage of Analogue Output 4
31			081F	2079	

Input signals (Commands)

Name of Command	Serial Code for single Command		Bit # of "Serial Commands" (OB01)	Possible assignment to hardware input X6 "Cont.In"	Explanation → chapter 9.1
	(Hex)	(Dec)			
Control Enable	0900	2304	0	In 1 ... 16	
Run Slave	0901	2305	1	In 1 ... 16	
Run Virt. Master	0902	2306	2	In 1 ... 16	
Reset	0903	2307	3	In 1 ... 16	
Trim + Slave1	0904	2308	4	In 1 ... 16	
Trim – Slave1	0905	2309	5	In 1 ... 16	
Trim + Slave2	0906	2310	6	In 1 ... 16	
Trim – Slave2	0907	2311	7	In 1 ... 16	
Trim + Slave3	0908	2312	8	In 1 ... 16	
Trim – Slave3	0909	2313	9	In 1 ... 16	
Trim + Slave4	090A	2314	10	In 1 ... 16	
Trim – Slave4	090B	2315	11	In 1 ... 16	
Index HTL Slave1	090C	2316	12	In 13 (fixed)	
Index HTL Slave 2	090D	2317	13	In 14 (fixed)	
Index HTL Slave 3	090E	2318	14	In 15 (fixed)	
Index HTL Slave 4	090F	2319	15	In 16 (fixed)	
Stop Slave1	0910	2320	16	In 1 ... 16	
Stop Slave2	0911	2321	17	In 1 ... 16	
Stop Slave3	0912	2322	18	In 1 ... 16	
Stop Slave4	0913	2323	19	In 1 ... 16	
Reset Slave1	0914	2324	20	In 1 ... 16	
Reset Slave2	0915	2325	21	In 1 ... 16	
Reset Slave3	0916	2326	22	In 1 ... 16	
Reset Slave4	0917	2327	23	In 1 ... 16	
Virt. Mast. Freq. +	0918	2328	24	In 1 ... 16	
Virt. Mast. Freq. -	0919	2329	25	In 1 ... 16	
Virt. Mast. Dir.	091A	2330	26	In 1 ... 16	
Teach Index Win.	091B	2331	27	In 1 ... 16	
Command 28	091C	2332	28	In 1 ... 16	
Store to EEPROM	091D	2333	29	In 1 ... 16	
Adjust Program	091E	2334	30	–	
Test Program	091F	2335	31	–	

Output Signals

Description	Serial Code for single output		Bit # of "Output Status" (0B04)	Possible assignment to hardware output X7 "Cont.Out"	Explanation → chapter 9.1
	Hex	Dec			
Ready	0A00	2560	0	Out 1 ... 8	
Alarm	0A01	2561	1	Out 1 ... 8	
Maximum Correct.	0A02	2562	2	Out 1 ... 8	
Index o.k.	0A03	2563	3	Out 1 ... 8	
Vir. M. in motion	0A04	2564	4	Out 1 ... 8	
Mast.1 in motion	0A05	2565	5	Out 1 ... 8	
Mast.2 in motion	0A06	2566	6	Out 1 ... 8	
Error	0A07	2567	7	Out 1 ... 8	
Alarm Slave 1	0A08	2568	8	Out 1 ... 8	
Alarm Slave 2	0A09	2569	9	Out 1 ... 8	
Alarm Slave 3	0A0A	2570	10	Out 1 ... 8	
Alarm Slave 4	0A0B	2571	11	Out 1 ... 8	
Max. Cor. Slave 1	0A0C	2572	12	Out 1 ... 8	
Max. Cor. Slave 2	0A0D	2573	13	Out 1 ... 8	
Max. Cor. Slave 3	0A0E	2574	14	Out 1 ... 8	
Max. Cor. Slave 4	0A0F	2575	15	Out 1 ... 8	
Index Slave 1 o.k.	0A10	2576	16	Out 1 ... 8	
Index Slave 2 o.k.	0A11	2577	17	Out 1 ... 8	
Index Slave 3 o.k.	0A12	2578	18	Out 1 ... 8	
Index Slave 4 o.k.	0A13	2579	19	Out 1 ... 8	
Index Window Sl. 1	0A14	2580	20	Out 1 ... 8	
Index Window Sl. 2	0A15	2581	21	Out 1 ... 8	
Index Window Sl. 3	0A16	2582	22	Out 1 ... 8	
Index Window Sl. 4	0A17	2583	23	Out 1 ... 8	
No Index in Win. 1	0A18	2584	24	Out 1 ... 8	
No Index in Win. 2	0A19	2585	25	Out 1 ... 8	
No Index in Win. 3	0A1A	2586	26	Out 1 ... 8	
No Index in Win. 4	0A1B	2587	27	Out 1 ... 8	
Output 28	0A1C	2588	28	Out 1 ... 8	
Output 29	0A1D	2589	29	Out 1 ... 8	
Output 30	0A1E	2590	30	Out 1 ... 8	
Output 31	0A1F	2591	31	Out 1 ... 8	

Status of Inputs and Outputs

Description	Serial Code		Explanation Bit# see tables above
	(Hex)	(Dec)	
Hardware Commands ("Cont.In" X6)	0B00	2816	
Serial Commands	0B01	2817	
CAN Commands	0B02	2818	
All Commands	0B03	2819	
Output Status	0B04	2820	