

PB251

Profibus-to-Serial Gateway
Profibus-DPV1 ↔ RS232 / RS485



Operating Instructions



Safety Instructions

- This manual is an essential part of the unit and contains important hints about function, correct handling and commissioning. Non-observance can result in damage to the unit or the machine or even in injury to persons using the equipment!
- The unit must only be installed, connected and activated by a qualified electrician
- It is a must to observe all general and also all country-specific and application-specific safety standards
- When this unit is used with applications where failure or maloperation could cause damage to a machine or hazard to the operating staff, it is indispensable to meet effective precautions in order to avoid such consequences
- Regarding installation, wiring, environmental conditions, screening of cables and earthing, you must follow the general standards of industrial automation industry
- - Errors and omissions excepted –

Version:	Description:
CA25102B/ TJ/ Jul. 03/P.8	Serial transmission with max. nine repeats

Table of Contents

1. Introduction.....	4
2. Block Diagram and Terminal Assignment.....	5
2.1. Power Supply.....	6
2.2. Profibus.....	6
2.3. Serial Interface.....	7
3. Settings.....	9
3.1. Profibus.....	9
3.2. Serial Interface.....	10
4. Communication.....	11
4.1. Communication Start-Up.....	11
4.2. Cyclic Data Exchange.....	12
4.3. Acyclic Data Transmission.....	12
4.4. Diagnosis and Errors.....	13
5. Listing of the GSD File.....	15
6. Technical Specifications.....	18
7. Dimensions.....	19

1. Introduction

The PB251 gateway has been designed to connect motrona units providing serial interface to Profibus-DP/DPV1 networks.

The PB251 units are Profibus-DP/DPV1 slaves. They can support cyclic data transmission (Profibus DP according to EN50170) as well as acyclic data transmission (extended DPV1 functions).

PB251 provides a RS232 and RS485 (2-wire / 4-wire) interface. For serial communication, the motrona / Lecom protocol according to DIN ISO 1745 is used. All motrona devices providing a serial interface, but also other devices using the same serial protocol can be connected to Profibus by the gateway.

The PB251 acts as a master of the serial communication site. At the present time only one slave unit can be connected to the serial interface, i.e. it is not possible to connect a RS485 bus system with several stations.



A printout of the GSD file necessary for use of this unit can be found under section 5. of this manual.

The GSD file itself is available on the CD included to each unit, or can be downloaded from our homepage

<http://www.motrona.com>

2. Block Diagram and Terminal Assignment

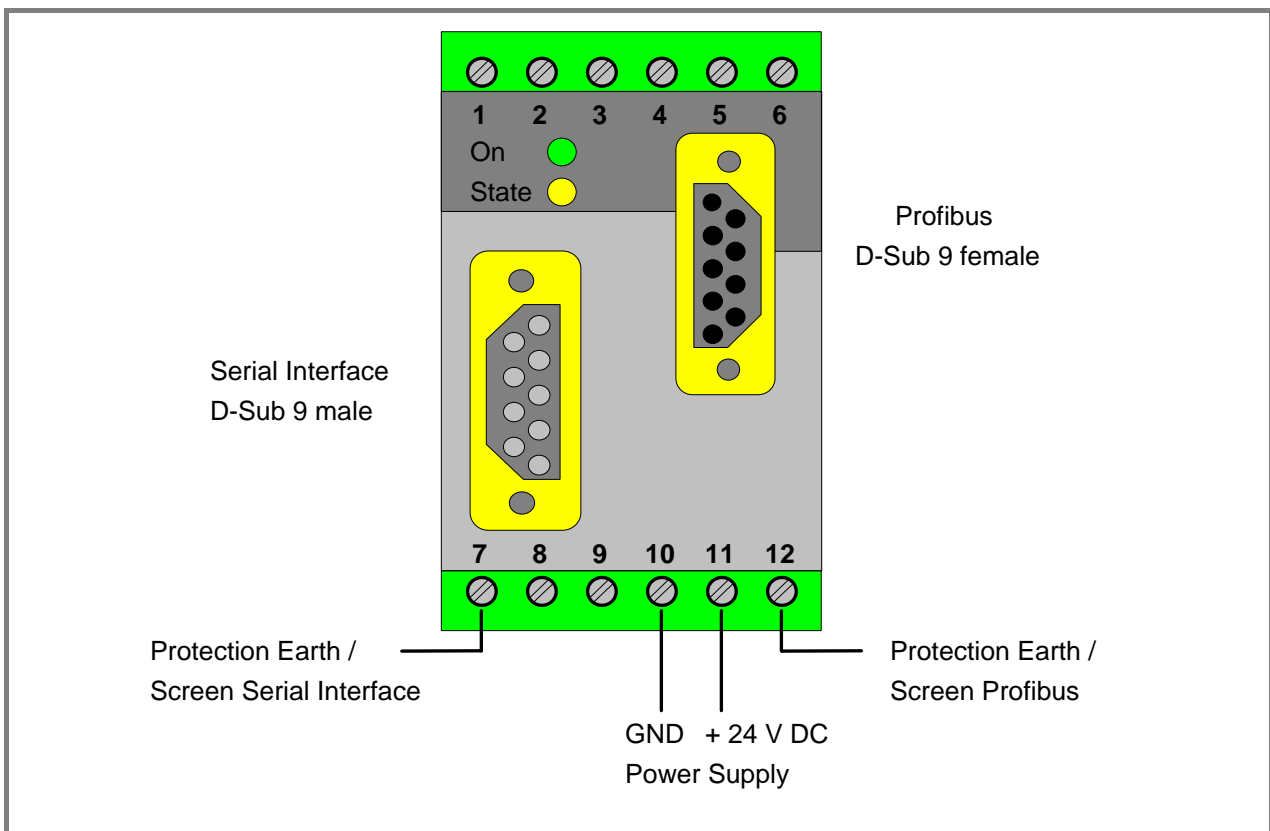
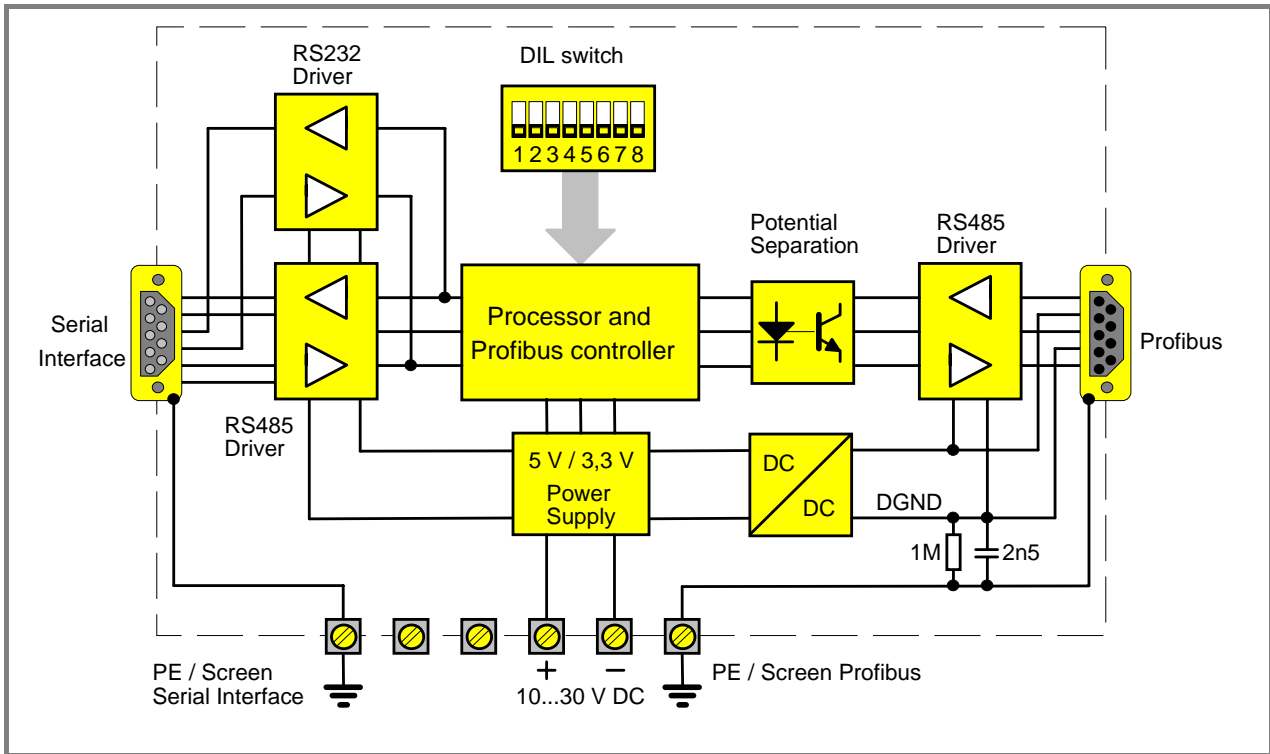

2.1. Power Supply

The unit operates from a power supply of 10 to 30 V DC connected to screw terminals 10 (-) and 11 (+). The power supply input is filtered and protected against polarity reversal.

2.2. Profibus

The Profibus connection is optically isolated. The Profibus driver is internally supplied from a DC/DC-converter and no auxiliary power supply needs to be applied to the Profibus connector.

Profibus connector pin assignment:

Pin:	Signal:	Meaning
1	Screen / Shield	Screen / Protection Earth
2	n. c.	–
3	RxD/TxD-P	Data +
4	CNTR-P (RTS)	Request To Send
5	DGND	Reference Potential (Ground)
6	VP	Aux. voltage output + 5 V / 50 mA
7	n. c.	–
8	RxD/TxD-N	Data -
9	n. c.	–

The following cables are recommended for Profibus (EN 50 170 "Type-A cable"):

Impedance:	135 ... 165 Ω
Capacitance:	< 30 pF / m
Loop resistance:	< 110 Ω / km
Wire diameter:	> 0,64 mm
Conductor cross section:	> 0,34 mm ²

Depending on the Baud rate, the following maximum cable length must not be exceeded:

Baud rate (kbit / s)	9,6	19,2	93,75	187,5	500	1500	3000	6000	12000
Max. cable length (m)	1200			1000	400	200	100		



On the extreme ends of the Profibus line (first unit and last unit) the bus must be terminated by a resistor network.

The cable shield must be connected to protection earth.

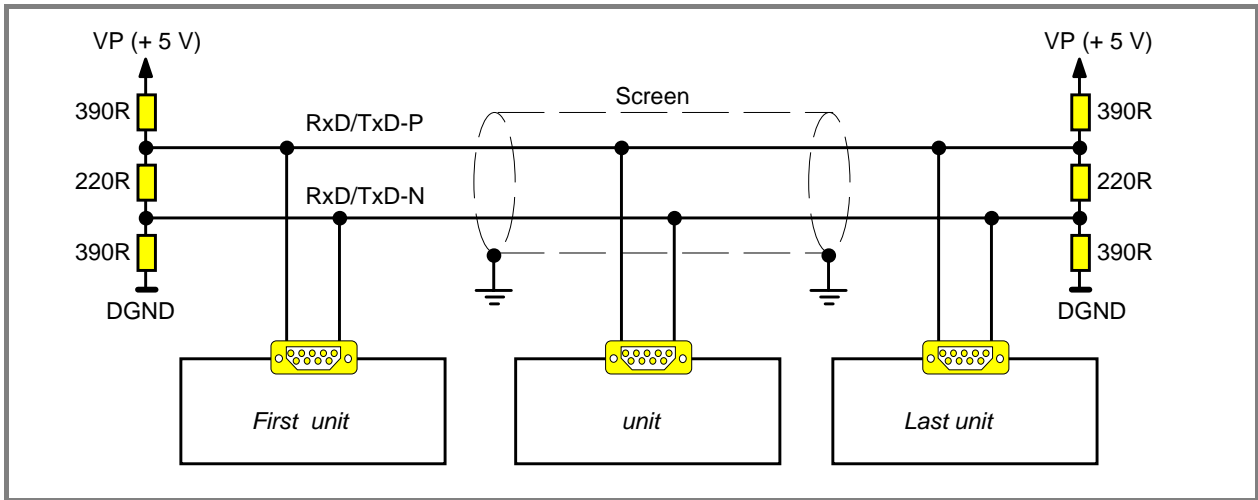

2.3. Serial Interface

The male type Sub-D connector provides a RS232 interface and a RS485 interface. As the drivers are connected in parallel it is not necessary to switch over between RS232, RS485 2-wire or RS485 4-wire communication modes.

Serial interface connector pinout:

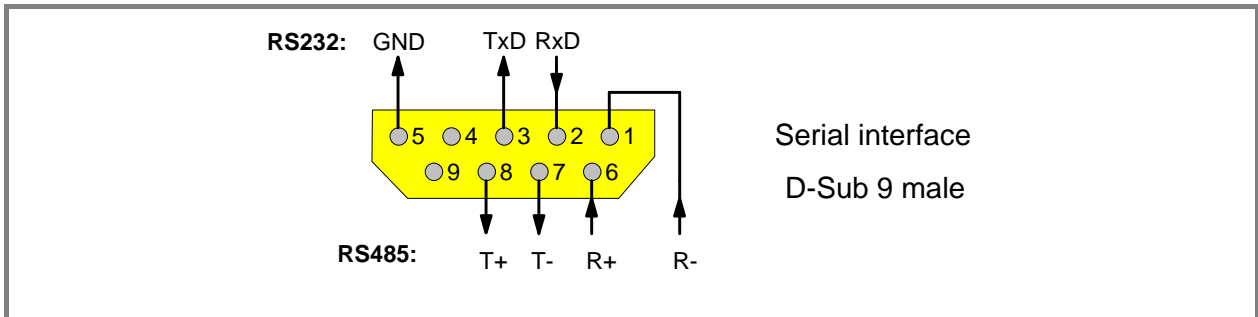

RS232 wiring:

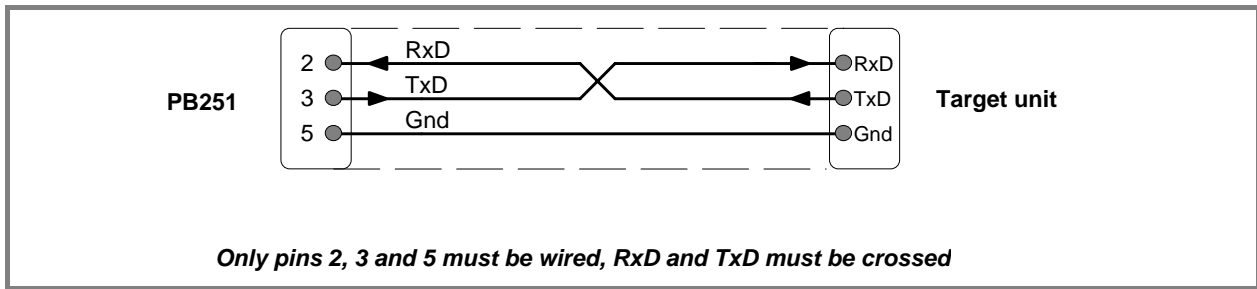

Please make sure your RS232 cable is using only the three pins shown. When also other pins are connected, this will cause interference with the RS485 pins and the RS232 communication will not work. The cable length should not exceed 15 m.

RS485 wiring:

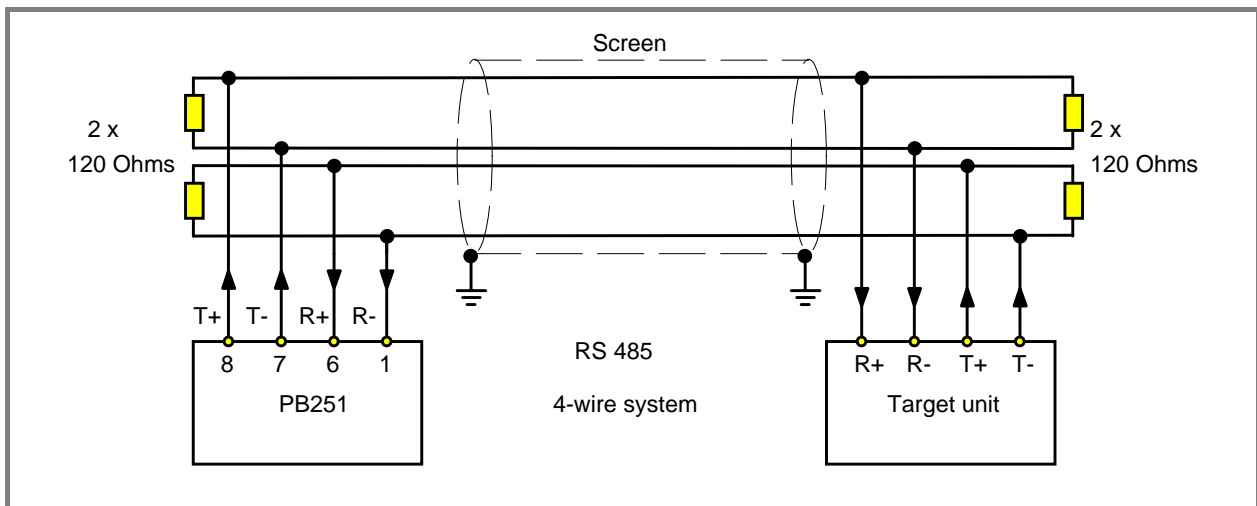
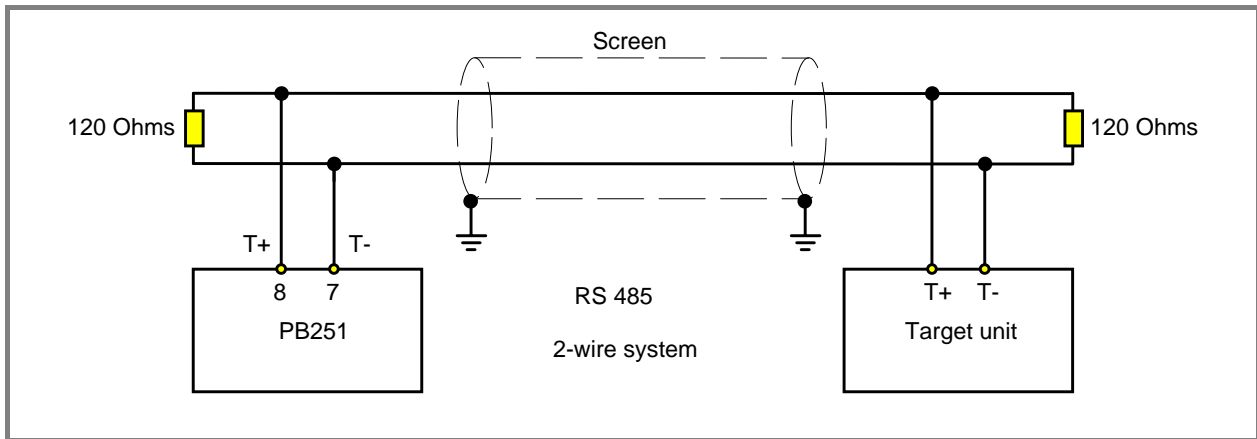

3. Settings

3.1. Profibus

The Profibus interface does not require a baud rate preset. The baud rate of the network is automatically recognized upon start-up of the communication.

All Profibus-DP baud rates from 9.6 kbit/s to 12 Mbit/s are supported.

Positions 2...7 of the DIL switch select the Profibus station address(setting range 3...126)

The address cannot be changed by the master by Set_Slave_Address service.

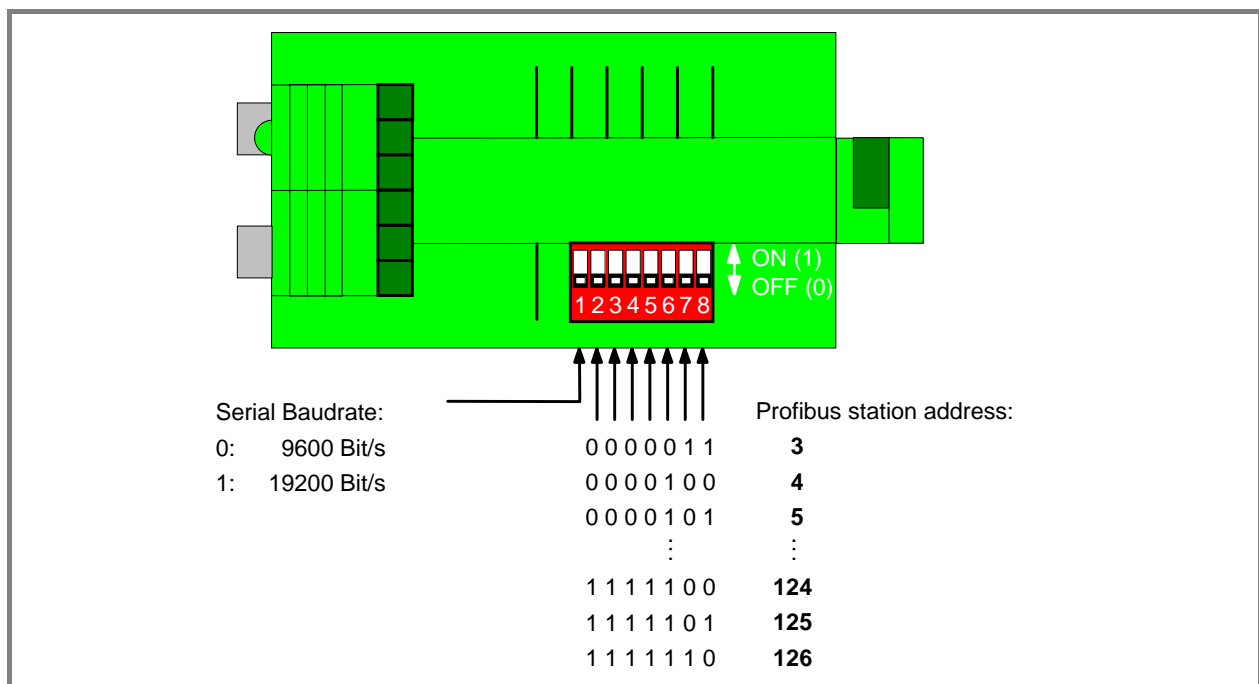

All DIL switch settings are only read upon initialization. Changes during normal operation will not be recognized!
After change of DIL switch settings, please cycle the power supply of the unit.

3.2. Serial Interface

DIL Switch position 1 selects the serial communication baud rate:

Off: 9600 Bit/s

On: 19200 Bit/s

The serial interface data format and the address of the target unit are permanently set to the values given below and cannot be changed:

Data format: 1 Start bit, 7 data bit, 1 stop bit, parity even.

Target unit address: 11

The serial communication is based on the LECOM protocol (patterned on DIN ISO 1745). Depending on the target unit on the serial site, standard addressing or extended addressing can be used. A detailed description of the serial protocol is available as document "SERPRO.pdf" from the "Download" site of the motrona homepage (www.motrona.com).

Customer-specific protocols are possible on request.

4. Communication

4.1. Communication Start-Up

During start-up of Profibus communication, the master parameterizes the unit. The transmit parameter data must consist of Profibus-DP parameter data (7 bytes), DPV1 parameter data* (3 bytes) and 3 additional user parameters (5 bytes):

status	wd_fact 1	wd_fact 2	tsdr	Ident high	Ident low	Group Ident	DPV1 Stat.1	DPV1 Stat.2	DPV1 Stat.3	(see below)
Profibus-DP parameter data							DPV1 parameter data*			5 byte user parameter data

The following table shows the meaning of the user parameters:

Byte:	1	2	3	4	5
User Parameter:	"Cyclic Request Parameter" high byte low byte		"Cyclic Send Parameter" high byte low byte		"Serial Mode"
Meaning:	Register Code of data requested cyclically from target unit (Profibus "input data")		Register Code of data transmitted cyclically to target unit (Profibus "output data")		Type of serial connected target unit (see below)

*) : See also hint in chapter 4.2 on p. 9

The user parameter "serial mode" selects the type of device connected to the serial interface:

- 1: motrona motion controllers **MC700/720** and third-party-products using Lecom protocol with extended addressing mode.
- 2: all actual motrona controllers / converters / display units providing a serial communication interface, except the units specified under 1. and 3.
- 3: motrona units of series AX, FX, IX, PX, QX, SX, ZX equipped with an optional serial interface (option RS500)
- 4: Third-party-products using Lecom protocol with standard addressing mode.
- 5: Reserved for some special versions of motrona controllers BY/CT/FS150 (use on consultation with motrona only)

After that, the master has to send the configuration of the cyclic data transmission to the slave:

Cyclic Transmission:	Configuration Data:	Meaning:
Cyclic read data only	93 hex	4 byte input data
Cyclic read and write data	B3 hex	4 byte input data + 4 byte output data

4.2. Cyclic Data Exchange

After successful start-up, cyclic data transmission begins.

The data received from the Profibus master (4 byte "output data") is transmitted via serial link to the target unit and stored to the register specified by the "Cyclic Send Parameter".

The value of the target unit register determined by "Cyclic Request Parameter" will be requested cyclically by the serial interface and transmitted to the Profibus master (4 byte "input data")

The target unit must respond to the serial transmission within a timeout period of 100 ms. If the response is negative or missing, the PB251 will repeat the transmission nine times more. If there is no positive response to the tenth trial, the cyclic communication will be aborted and the unit will go to the Profibus state "Wait_Prm". The error is indicated by the yellow state LED and by the diagnosis data (see chapter 4.4). To reset this error, the Profibus master must again parameterize the PB251 and restart the Profibus communication.



The cyclic data transfer can also be operated by a Profibus-DP master without extended DPV1 functions. In this case, upon parameterization, the Profibus-DP master must omit the 3 bytes of DPV1 parameter data or set them all to zero.

4.3. Acyclic Data Transmission

For acyclic data transmission the DPV1 services "Initiate" (Establishment of a connection), "DS_Read" (read data from slave), "DS_Write" (write data to slave) and "Abort" (Termination of the connection) are used. The PB251 does not support the DPV1 service "Data_Transfer" (read and write data in the same service cycle).

The register number of the target unit the data is read from and written to, respectively, is determined by a so-called Slot_Number and a so-called "Index".

If the PB251 is connected to a target unit using 4-digit register codes (Lecom extended addressing mode), e. g. MC700/720, the Slot_Number must contain the high byte of the register code and the Index must contain the low byte of the register code.

If you have connected a target unit using only 2-digit register codes (Lecom standard addressing mode), e. g. BY125, BY/CT/FS150, IV251 etc., the slot number must always be set to 0 and the index must contain the register code.

To read out the actual value registers (code ":0" and following), the Index must be set to 100 (64hex) and following.

If an error occurs during serial transmission, or if a service cannot be executed because e.g. the selected register does not exist in the unit or the register value is out of range, the acyclic request frame will be replied by a negative response frame.



The acyclic communication can not be operated before the PB251 has been parameterized by the Profibus master, since the User Parameter "Serial Mode" selects the type of unit and therefore the type of serial protocol to be used.

4.4. Diagnosis and Errors

The diagnosis data consist of 6 byte Profibus-DP diagnosis data and 5 byte DPV1 device specific diagnosis data:

diag 1	diag 2	diag 3	diag 4	Ident high	Ident low	sign_len = 05 hex	status_type = 81 hex	slot_nr= 00	specifier = 00	Error , = XX
Profibus-DP diagnosis data						device specific diagnosis data ("State PDU")				

The byte "Error" will denote the reason causing the serial communication error:

"Error": (hex)	Serial Communication Error Reason:
01*	Parity error or stop bit error
02*	Checksum error
04*	Serial buffer overflow
08*	Timeout (no response or invalid response)
10	Negative response
20	Code does not exist
30	Invalid request
40	Wrong control character
50	Response contains wrong code
60	Response contains wrong sub-code
70	Data format not supported
F0	Other error

*) These error numbers can be added since the errors can occur at the same time

PB251 does not use DPV1 alarms at all.

The actual communication state of the slave unit is indicated by a yellow state LED:

LED:	Profibus-DP state:	Device state:
off		Fatal Error
flashing slowly	Wait_Prm Wait_Cfg	Ready, waiting for start-up
on	Data_Exchange	Communication active
flashing quickly	Data_Exchange → Wait_Prm	Serial Communication Error

A fatal error can be reset only by cycling the power supply of the unit.

5. Listing of the GSD File

```
*****
;
;
;       GSD-File for PB251
;
;
;       File:           mksr0635.gsd
;       Version:        05
;       Date:           07.01.2008
;       Author:         Thomas Jaeckle
;
;
;       motrona GmbH
;       Zwischen den Wegen 32
;       78239 Rielasingen - GERMANY
;       Tel.: ++49-7731-9332-0 Fax: ++49-7731-9332-30
;       Email: thomas.jaeckle@motrona.com
*****
#Profibus_DP
;
;General parameters:
;
GSD_Revision = 3
Vendor_Name = "motrona"
Model_Name = "PB251"
Revision = "01"
Ident_Number = 0x0635
Protocol_Ident = 0                ; Profibus-DP
Station_Type = 0                  ; Slave
FMS_supp = 0                      ; No FMS supported
Hardware_Release = "01"
Software_Release = "01"
;
9.6_supp = 1                      ; Supported baudrates
19.2_supp = 1
93.75_supp = 1
187.5_supp = 1
500_supp = 1
1.5M_supp = 1
3M_supp = 1
6M_supp = 1
12M_supp = 1
;
MaxTsdr_9.6 = 60
MaxTsdr_19.2 = 60
MaxTsdr_93.75 = 60
MaxTsdr_187.5 = 60
MaxTsdr_500 = 100
MaxTsdr_1.5M = 150
```

```

MaxTsdr_3M = 250
MaxTsdr_6M = 450
MaxTsdr_12M = 800
;
Redundancy = 0
Repeater_Ctrl_Sig = 2 ; RTS-Signal (CNTR-P): TTL-level
24V_Pins = 0 ; No 24V supply on Profibus-connector
Implementation_Type = "DPC31"
;
; Slave-Specification:
;
Freeze_Mode_supp = 1 ; Freeze-Mode supported
Sync_Mode_supp = 1 ; Sync-Mode supported
Set_Slave_Add_Supp = 0 ; Set_Slave_Address not supported
Auto_Baud_supp = 1 ; Automatic baudrate recognition
Min_Slave_Intervall = 6
Fail_Safe = 1 ; Fail-Save-Mode supported
;
Max_Diag_Data_Len = 11 ; 5 byte user diagnostic data
Modul_Offset = 0
Slave_Family = 9 ; Gateway
Modular_Station = 1
Max_Module = 1 ; Modular station with one module
Max_Input_len = 4 ; max. 4 byte input data
Max_Output_len = 4 ; max. 4 byte output data
Max_Data_len = 8 ; max. 2 * 4 byte data
;
; UserPrmData:
;
Max_User_Prm_Data_Len = 8 ; 3 byte DPV1 parameter + 5 byte user parameter data
;
; <Ext-User-Prm-Data-Def-List>
;
ExtUserPrmData = 1 "Cycl. Req. Param." ; User parameter
Unsigned16 0 0-0x7fff ; Type, default value, value range
EndExtUserPrmData
;
ExtUserPrmData = 2 "Cycl. Send Param." ; User parameter
Unsigned16 0 0-0x7fff ; Type, default value, value range
EndExtUserPrmData
;
ExtUserPrmData = 3 "Serial Mode" ; User parameter
Unsigned8 1 1-5 ; Type, default value, value range
EndExtUserPrmData
;
Ext_User_Prm_Data_Const(0) = 0x00, 0x00, 0x00 ; 3 byte DPV1 parameter
Ext_User_Prm_Data_Const(3) = 0x00, 0x00, 0x00, 0x00, 0x00 ; 5 byte user parameter

```



```

Ext_User_Prm_Data_Ref(3) = 1
Ext_User_Prm_Data_Ref(5) = 2
Ext_User_Prm_Data_Ref(7) = 3
;
;
; Module Definition List (Configuration):
;
Module="Cyclic Read and Write" 0xB3           ; 4 byte input data + 4 byte output data
1
EndModule
Module="Cyclic Read only" 0x93             ; 4 byte input data, no output data
2
EndModule
;
;
; DPV1:
;
DPV1_Slave = 1
C1_Read_Write_supp = 1
C2_Read_Write_supp = 1
C1_Max_Data_Len = 240
C2_Max_Data_Len = 240
C1_Response_Timeout = 100                 ; in units of 10ms, optional
C2_Response_Timeout = 100                 ; in units of 10ms, optional
C1_Read_Write_required = 0
C2_Read_Write_required = 0
C2_Max_Count_Channels = 1
Max_Initiate_PDU_Length = 64
Diagnostic_Alarm_supp = 0
Process_Alarm_supp = 0
Pull_Plug_Alarm_supp = 0
Status_Alarm_supp = 0
Update_Alarm_supp = 0
Manufacturer_Specific_Alarm_supp = 0
Extra_Alarm_SAP_supp = 0
Alarm_Sequence_Mode_Count = 0
Alarm_Type_Mode_supp = 0
Diagnostic_Alarm_required = 0
Process_Alarm_required = 0
Pull_Plug_Alarm_required = 0
Status_Alarm_required = 0
Update_Alarm_required = 0
Manufacturer_Specific_Alarm_required = 0
; DPV1_Data_Types = 0                     ; optional
WD_Base_1ms_supp = 1
Check_Cfg_Mode = 0
;
;-----

```

6. Technical Specifications

Power supply	:	10...30 V DC
Current consumption	:	ca. 100 mA (24 V)
Profibus Communication	:	Profibus-DP/DPV1 Slave
Identification-Number / GSD file	:	0635 hex / mksr0635.gsd
Profibus Baud rates	:	9.6 / 19.2 / 93.75 / 187.5 / 500 kbit/s, 1.5 / 3 / 6 / 12 Mbit/s
Serial communication	:	RS232, RS485 2-wire / 4-wire
Serial communication protocol	:	Lecom (DIN ISO 1745)
Serial Baud rates	:	9600 / 19200 bit/s
Operating temperature	:	0...45°C / 32...113°F
Weight	:	approx. 170 g
Conformity and Standards	:	EMC 89/336/EEC : EN 61000-6-2 EN 61000-6-3 LV73/23/EEC : EN 61010-1

7. Dimensions

