

VS1 Vibration Monitor User's Manual

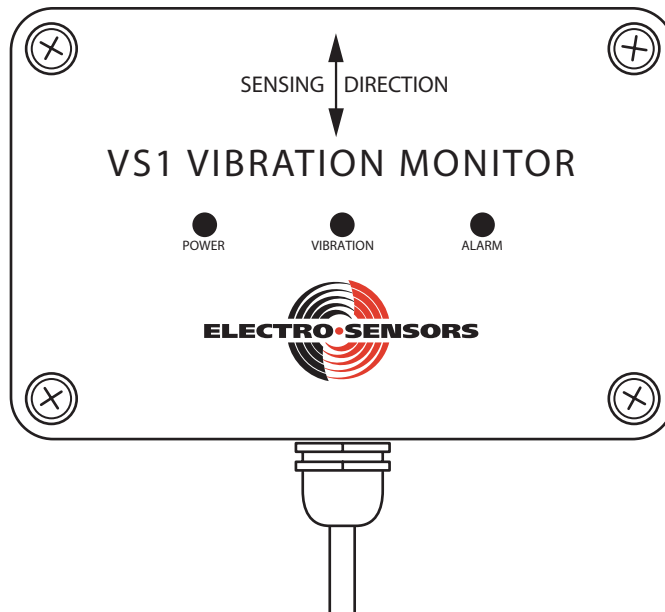

Description

The VS1 Vibration Monitor combines sensor, circuitry and isolated npn or relay output into a compact NEMA 4X package. It monitors the machine surface to which it is attached and alarms when vibration levels either exceed or fall below the trip-point setting (depending on the ALARM switch setting).

Operator Interface/Dimensions

The setting dials and switch are located under the waterproof cover. Remove the cover to change settings and replace when finished.

Cover Removed

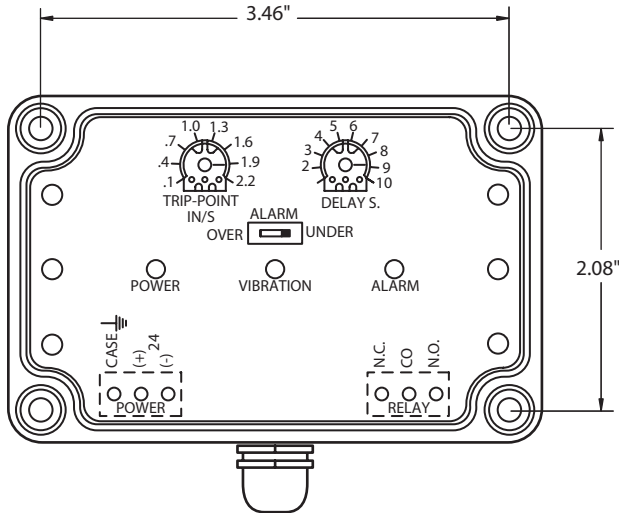

Cover Attached

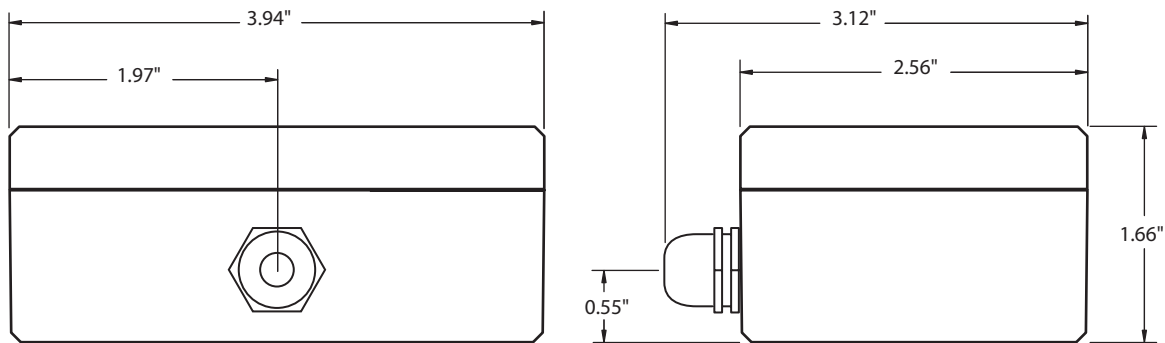

Installation

Orientation

The VS1 senses vibration along the axis indicated by the SENSING DIRECTION arrow. Orient the VS1 with the arrow parallel to the vibration axis to be monitored.

Mounting

The VS1 enclosure has four mounting holes. The mounting holes are the same as the cover attachment holes (located directly underneath the captive cover screws when the cover is on). Remove the cover to access the mounting holes (see Operator Interface/Dimensions). Use four 8-32 UNC (or M4 metric) hex socket-head cap screws to mount the VS1. Rigid, tight attachment is necessary for any vibration-sensing device. For this reason the VS1 must be securely fastened to a smooth, flat surface. Use all four screws: mounting with fewer can allow error-causing resonance when high-frequency vibrations are present.

Cabling

The VS1 comes standard with a 10' cable. When extending the cable to a longer length, terminate it in an appropriate junction box with proper terminal strips. The cable wires have the following color code:

Power

Green	Case
Red	DC Power (+)
Black	DC Power (-)

NPN Output Option

Blue	Collector Protection Cathode
Orange	Emitter
White	Collector

Relay Output Option

Blue	Relay Common
Orange	Relay N.C.
White	Relay N.O.

Free Catalog and Application Assistance:

1-800-328-6170

ISO9001:2000

6111 Blue Circle Drive, Minnetonka, MN 55343 USA



Superior • Systems • Solutions

www.electro-sensors.com

Visit us online:

Phone: 952-930-0100 Fax: 952-930-0130

Operation

Power LED (Green)..... Indicates power applied to the VS1.

Vibration LED (Green) Indicates vibration at or above the minimum detectable level (0.1 in/s nominal).

Alarm LED (Red)..... Indicates an alarm condition.

Note: Alarms are not latching – an alarm condition persists only while the vibration magnitude stays at alarm levels.

Alarm OVER/UNDER Switch Selects the alarm functionality.

Over: Alarms while vibration magnitude is above the trip-point setting.

Under: Alarms while vibration magnitude is below the trip-point setting.

Trip-Point Dial Sets the alarm level threshold in inches-per-second RMS.

Delay Dial Sets the alarm delay in seconds.

An alarm occurs DELAY seconds after detecting vibration magnitude at alarm level. The vibration magnitude must remain at alarm levels for at least DELAY seconds for an alarm to occur.

NPN Output Option The isolated NPN output is connected for failsafe operation (NPN on when powered and not alarmed).

It operates as follows:

Conducting (ON) when VS1 is powered and not alarmed

Not conducting (OFF) when VS1 is unpowered or alarmed.

Relay Output Option The isolated SPDT relay is connected for failsafe operation (relay is energized when VS1 is powered and not alarmed). The contacts operate as follows:

N.C. Disconnected from COM (energized) when VS1 is powered and not alarmed.

Connected to COM (not energized) when VS1 is unpowered or alarmed.

N.O. Connected to COM (energized) when VS1 is powered and not alarmed.

Disconnected from COM (not energized) when VS1 is unpowered or alarmed.

Settings

With the VS1 tightly mounted, the cover removed, and 24 Vdc power applied*, complete the following steps:

1. Set the ALARM OVER/UNDER switch as required.
2. Set the TRIP-POINT. If the desired RMS velocity alarm value is known, set the trip point to that value, otherwise it can be set experimentally relative to your machine's current (acceptable) vibration level. The following gives an example (ALARM set to OVER):
 - a. Set the DELAY to minimum (1 second).
 - b. Start the machine to be monitored.
Note: The VIBRATION LED should light, indicating vibrations above the VS1 minimum detectable level (0.1 in/s). Wait for any/all transient vibrations to die out.
 - c. Slowly increase the TRIP POINT setting until the ALARM LED darkens (if already alarmed).
 - d. Slowly decrease the TRIP POINT setting until the ALARM LED begins to light. This setting is your current vibration level.
Note: These last two steps may need to be repeated. Adjust the TRIP POINT slowly since there is a minimum of 1 second response time.
 - e. Increase the TRIP POINT to a value proportional to the current vibration level. For example, if the current vibration level is 0.5 in/s and you want the VS1 to alarm at 40% above that, set the trip point to 0.7 in/s.
3. Set the DELAY. This may also have to be determined experimentally, depending on the duration of vibration transients to be ignored.
4. Re-attach the cover tightly.

* Note: There is a 2-3s. delay from application of DC power to becoming operational (to allow internal circuitry to charge).

Free Catalog and Application Assistance:

1-800-328-6170

ISO9001:2000

6111 Blue Circle Drive, Minnetonka, MN 55343 USA



Superior • Systems • Solutions

Visit us online:
www.electro-sensors.com

Phone: 952-930-0100 Fax: 952-930-0130

Specifications

LED Indicators

Power	Green
Vibration	Green - indicates vibration above min. detectable level (0.1 in/s rms)
Alarm	Red - indicates output in alarm state

Settings/Ranges

Alarm trip point.....	0.1 - 2.2 in/s (2.5 - 55 mm/s) rms
Alarm delay.....	1 - 10 seconds
Alarm	Over/under select switch

Operational Limits

Min. vibration frequency (-3db)	10 Hz
Max. vibration acceleration.....	± 50 g peak (NPN option) ± 12 g peak (Relay option)

Power Requirements

Voltage	24 Vdc (18 - 30 Vdc)
Current (max).....	30 mA @ 24 Vdc

Note: Optional 24 Vdc/130 mA power supply available, consult factory.

Relay (Relay option)

Type.....	SPDT
DC rating	5A @ 30 Vdc
AC rating.....	5A @ 250 Vac
Failsafe.....	Relay energized when powered and not alarmed

Isolated NPN Output (NPN output option)

Current	50 mA
V_{CE} (max @ 50 mA).....	1.0 V
BV_{CEO} (breakdown volts).....	100 V
P_D (max power over temp).....	100 mW
I_{CEO} (max leakage over temp).....	100 μ A
Failsafe.....	Transistor ON when powered and not alarmed

Terminals/Connections

Cable	6 conductor, unshielded, 22 AWG	
	NPN Option	Relay Option
Green	Case	Case
Red	DC Power (+)	DC Power (+)
Black.....	DC Power (-)	DC Power (-)
Blue.....	Collector Protection Cathode	Relay Common
Orange	Emitter	Relay N.C.
White.....	Collector	Relay N.O.

Environmental

Operating Temperature	-40°C to 65°C (-40°F to 149°F)
Enclosure type.....	Cast aluminum, NEMA 4X

Mechanical

Weight	0.75 lb (0.34 kg)
Dimensions.....	3.94" x 2.56" x 1.66"

Specifications subject to change without notice.

NPN Output Schematic and Possible Connections (NPN Output Option)

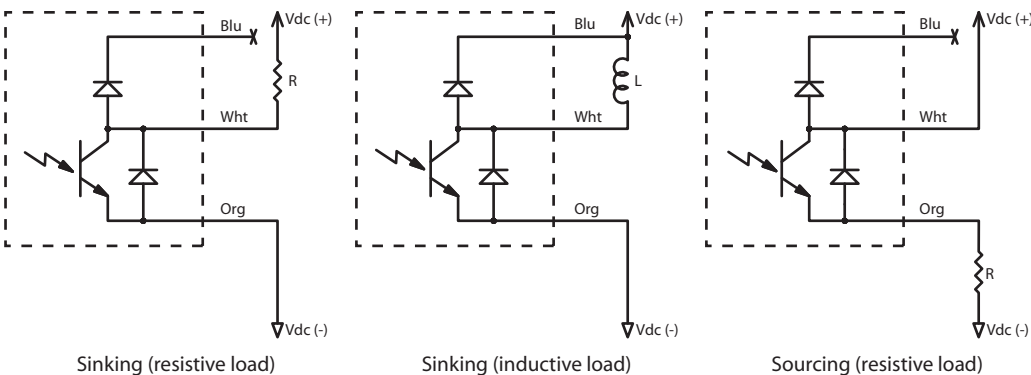

The NPN output is electrically isolated from the VS1 DC power inputs and case. The NPN output may be externally connected to the same supply as the DC power inputs or to a different supply.

Relay Output Schematic (Relay Output Option)

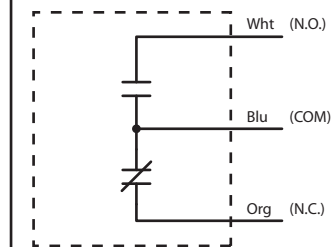

The relay output is electrically isolated from the VS1 DC power inputs and case

Useful Conversion Formulas

Definitions:

CPM	Machine cycles per minute
f	Frequency
Stroke	Max machine travel (peak to peak)
Disp_{pk}	Peak displacement from center position (Stroke / 2)

Formulas:

f (frequency in Hz)	$= \text{CPM} / 60$	
Vel_{rms} (rms velocity in in/s)	$= 4.44 * \text{Disp}_{pk} * f$	Disp _{pk} must be in inches, f must be in Hz
Accel (peak acceleration in g's)	$= 0.103 * \text{Disp}_{pk} * f^2$	Disp _{pk} must be in inches, f must be in Hz
Accel (peak acceleration in g's)	$= 0.0231 * \text{Vel}_{rms} * f$	Vel _{rms} must be in in/s rms, f must be in Hz

Note: All formulas based on sinusoidal motion.

Free Catalog and Application Assistance:

1-800-328-6170

ISO9001:2000

6111 Blue Circle Drive, Minnetonka, MN 55343 USA



Superior • Systems • Solutions

www.electro-sensors.com

Visit us online:

Phone: 952-930-0100 Fax: 952-930-0130