

HazardPRO™

Wireless Hazard Monitoring

CELEBRATING



1968 YEARS 2018

Electro-Sensors is revolutionizing the way hazard monitoring is done, with its turnkey **HazardPRO™** systems. Rugged sensors and the most advanced wireless technology combine to create the best hazard monitoring solution with the lowest installed cost.



Electro-Sensors.com

Reliable • Simple • Complete

When it comes to hazard monitoring, we know it simply has to work. **HazardPRO** was designed from the ground up to provide turnkey, reliable, and consistent protection for your most valuable assets, products, facilities, and most importantly, people. Consistent operation is ensured with built-in tools such as self-diagnostics, transmission logging, and redundant transceivers providing you confidence that your critical processes are being monitored and logged at all times.

As a truly integrated system built expressly for hazard monitoring, **HazardPRO** captures and displays key information in an intuitive format allowing the user to quickly and comprehensively understand the status of their processes. The simple but powerful interface will give you insight into your operations as you strive to maximize safety and facility runtime, while minimizing costs associated with unscheduled maintenance and unplanned downtime.

Status At-A-Glance

- Quickly view what processes are running and their condition from the status screen
- Easy touchscreen navigation guides the user through equipment information

Real-Time Information

Intelligent transmitter nodes send information both on a scheduled periodic basis and when important changes are detected, ensuring that there are no polling delays or lapses in monitoring.

- Live charts continually update
- View sensor status over time leading up to an event
- Evaluate trending with interactive history charts
- Data, alerts, and alarms available through secured wireless networks
- Access information via tablets, smartphones, and PCs with Internet access

Accountability & Security

- User access levels are set by plant administrators
- Events are automatically logged for review
- Only users with password-validated authority can edit or close events
- Users can document event cause and resolution
- Full password protection secures Internet access

Full Integration With Your Controls

Easily integrate to your existing plant control or PLC system via:

- Modbus TCP/IP communication
- A traditional switch input/relay output system

Wear-Detect Belt Alignment

- No need to shut down the conveyor belt for rub block inspection
- A warning will be displayed when a replacement belt alignment sensor is needed
- Rate-of-rise setpoints provide additional protection

Ambient Sensors – Fewer False Alarms

- Multiple ambient temperature sensors automatically adjust setpoints eliminating the need for broad setpoint ranges
- Absolute shutdown settings are maintained to prevent catastrophic events

Approvals

HazardPRO™ Sensors

- Intrinsically Safe (I.S.) in:
 - Class II, Div. 1, Groups E, F, G; Class III

HazardPRO™ Node

- Intrinsically Safe (I.S.) apparatus located in:
 - Class II, Div. 1, Groups E, F, G; Class III
- Providing Intrinsically Safe (I.S.) circuits for use in:
 - Class II, Div. 1, Groups E, F, G; Class III



Industries Served

- Grain, Feed & Milling
- Ethanol Processing
- Waste Water
- Bulk Materials
- Bio Mass
- Mining/Quarries
- Port Handling
- Food Processing
- Packaging
- Timber Processing

FEATURES & CONCEPT

Shaft Speed



Bearing Temperature

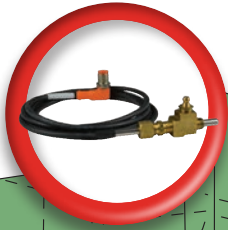

Ambient Temperature

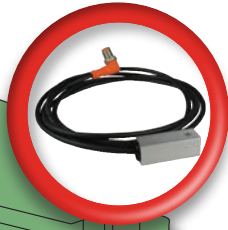

Belt Alignment



Transmitter Node



System Manager

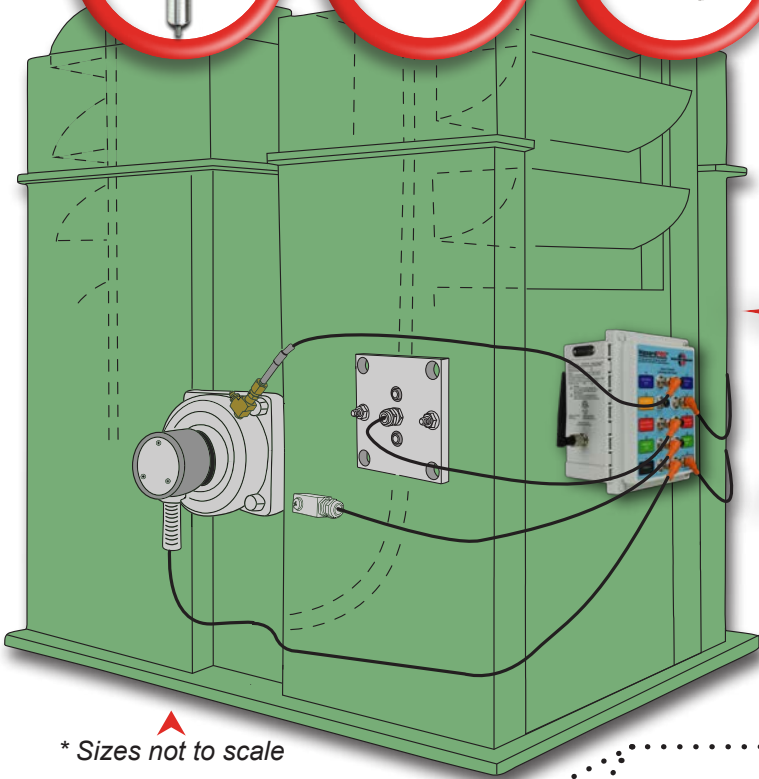

* Sizes not to scale

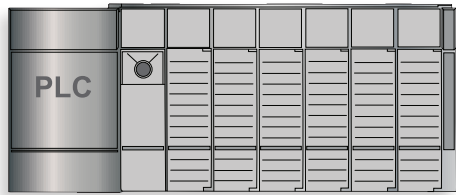
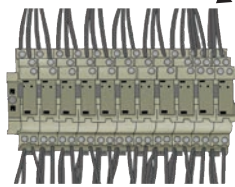

Plant Control System

- Modbus TCP/IP
- Control Relays "Run/Stop"
- Control Switches "Run/Stop"



Any device, anytime, anywhere.

View status, receive and respond to alerts, silence alarms, or shut down equipment.

Remote Access

- PC/Laptop
- Tablet
- Smartphone



HazardPRO XL System Manager

System Status Screen

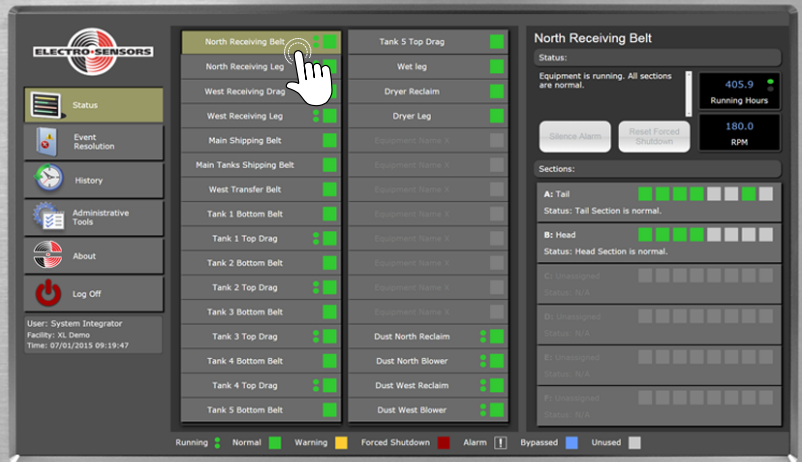

Circle Drive • Minnetonka, MN 55343
 612 • 800-328-6170 • electro-sensors.com

© 2014 Electro-Sensors, Inc.

Node View Screen

Sensor values, setpoints, and alarm conditions

Sensor Trend Screen

Live Chart

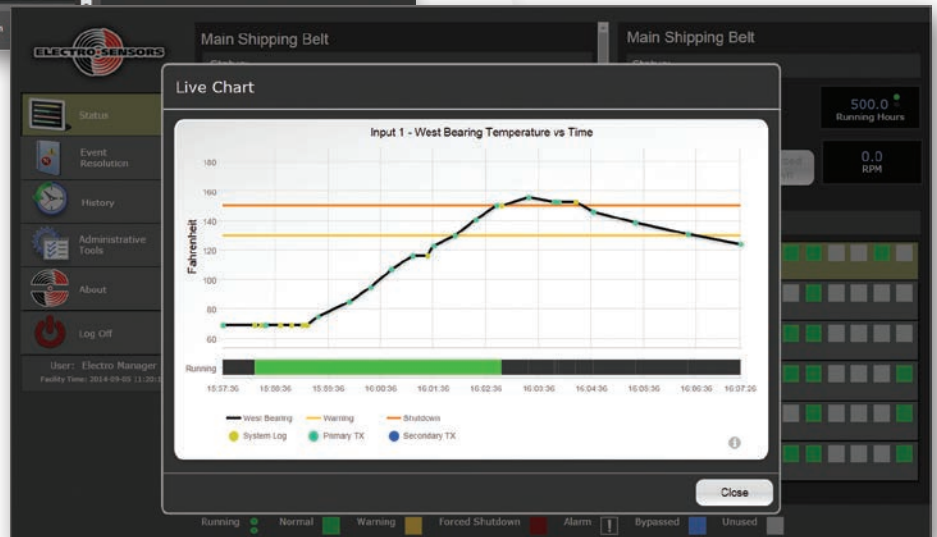

USER INTERFACE



Event Screen

- Time-stamped event log
- Event overview details with graphical snapshot and input identification
- Cause of event and resolution text fields for logging event information
- Sign-off and date stamp

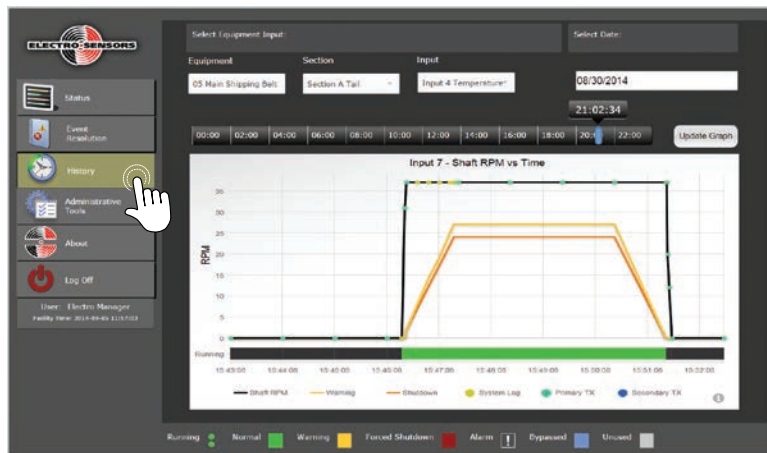

History Screen

- Historical graph for all sensors
- Selectable 24-hour window
- 1+ year history log
- Internal data storage

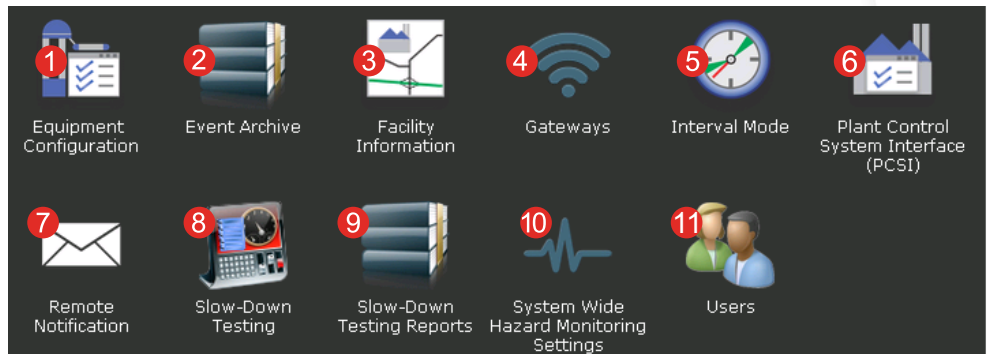
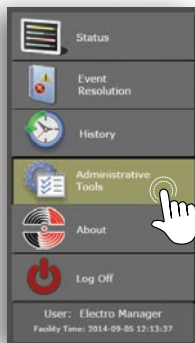

- 1 Quickly and easily add equipment as needed
- 2 Warning/shutdown events and resolutions are archived
- 3 Set the company's facility information
- 4 View gateway information and enter/edit settings
- 5 Allows periodic conveyor operation in cold weather to prevent freeze-up
- 6 View PLC and I/O board interface information and enter/edit settings
- 7 Enter e-mail addresses for select individuals to receive notifications for specified events
- 8 Slowdown test to verify the correct operation of the hazard monitoring system and the plant control system
- 9 View and print historical slow-Down test reports
- 10 Set the system-wide default settings
- 11 Modify and/or add new users to the system



Bucket Elevators



Bucket elevators are key to grain elevator operations. Monitor your alignment, temperature, and speed to provide safe and streamlined operations in your facility.

Grain Bins



Grain bins store tons of valuable product in every facility. These bins can be susceptible to fires that can result in lost profit. Wireless hazard monitoring sensors provide you with a method to monitor your bin sweep temperature and prevent bin fires from happening to you.

Tripper Cars



Tripper cars are instrumental to grain storage. Tripper cars provide unique opportunities for hazard monitoring as the movement makes Class II Div. 1 monitoring difficult. HazardPRO wireless sensors can be mounted directly to the tripper car, providing monitoring for speed, temperature and alignment. Wireless hazard monitoring provides a solution to the most difficult equipment to be monitored in your facility.

Overhead Cranes



Overhead cranes handle and load endless amounts of merchandise and product. Monitoring the moving segment of a crane for speed and bearing temperature provides you with the confidence that is needed to ensure that your facility remains operational at all times.

Conveyors



Whether your conveyor is handling rock, grain, coal, waste, or any material vital to operations, you can be confident that your machinery will continue operating without unexpected failure. Monitoring conveyor speed, temperature, and alignment will keep your equipment running better, longer, and more efficiently. Monitored data can be viewed and used to perform preventive maintenance.

Wood Processing Press



Panel manufacturing plants that are responsible for the production of MDF & OSB panels deal with a lot of combustible dust. Wireless hazard monitoring provides a dust certified solution for large facilities. Monitoring bearings for rising temperature keeps production lines rolling while also ensuring the safety of plant personnel.

Plant Integration

System Flow Chart

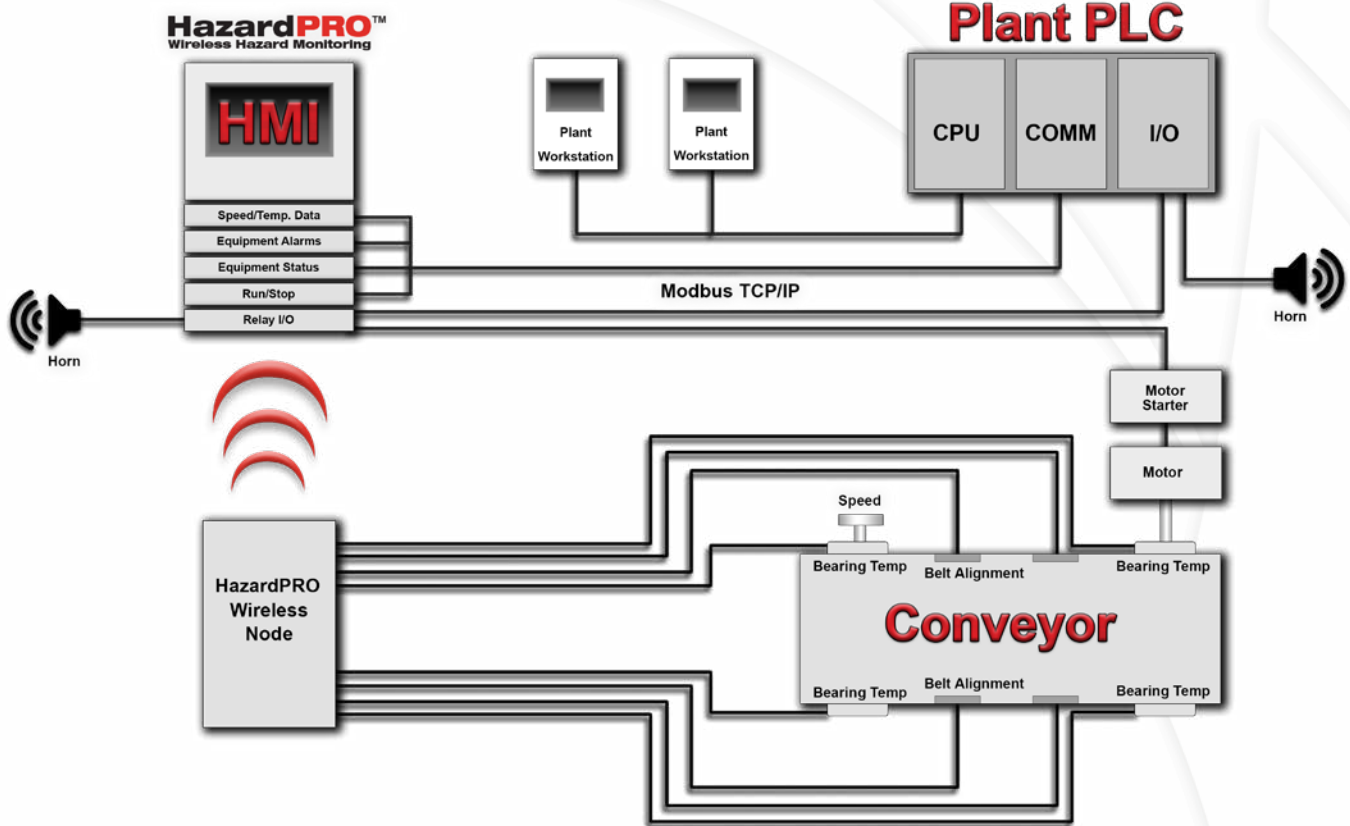

Register Control & Relay Output

HazardPRO systems are completely stand-alone and capable of providing monitoring data for any of your plant equipment. Modbus TCP/IP connection allows plant control systems to receive status or register information from the HazardPRO system manager. This is very useful for facilities that require integration of hazard monitoring equipment with their plant control system.

Run/Stop Interface

Equipment #	Modbus Register	Value
1	40001	0
2	40002	1
3-31	:	:
32	40032	0

Equipment State Interface

Node #	Modbus Register	Value
1	41001	Node State
	41002	Comm Link OK
	41003	Node Health OK
	41004	Sensor 1 Value
	:	
	41013	Sensor 10 Value
	:	
	41016	Sensor 1 State
	:	
	41025	Sensor 10 State
2-95	:	
96	47361	Node State
	:	
	47390	Sensor 10 State

Equipment State Interface

Equipment #	Modbus Register	Value
1	40101	1
2	40202	3
3-31	:	:
32	40232	0

System Manager

- Modbus TCP/IP communication
- SPDT relay for each piece of equipment plus one relay for audible notification
- Controlled levels of access
- Real-time information and live charting
- Redundant transceivers for error-free communication

Sizes

- XS (1-4 pieces of equipment, 12 Nodes, 120 Sensors)
 - XM (Up to 16 pieces of equipment, 48 Nodes, 480 Sensors)
 - XL (Up to 32 pieces of equipment, 96 Nodes, 960 Sensors)
- * Sensor numbers are including 2 ambient sensors per node



Wireless Savings

- \$ Ease of Installation**

With HazardPRO wireless systems all nodes and sensors are certified Intrinsically Safe by ETL and do not need to be wired for power. This means that whenever you install a wireless node and the associated sensors you do not need an electrician. This makes installation quick and cost effective to you.
- \$ Conduit-Free Installations**

HazardPRO does not require the conduit or labor costs that are required to install traditional hazard monitoring systems. As such, you can count on substantial savings to the bottom line of your system installation.
- \$ No Software Programming**

When your facility decides to monitor additional equipment, you can simply add equipment without making any software changes. Adding extra equipment is now easier than ever.
- \$ Reduced Facility Downtime**

With other systems, installation can be a nightmare for plant managers but with HazardPRO your entire hazard monitoring system can be installed in a matter of days. This results in significantly reduced down time, which results in increased productivity during installation.
- \$ Preventive Maintenance**

Preventive maintenance is an important aspect for any facility. HazardPRO tracks live sensor values and displays them in data graphs, these graphs provide valuable insight into your plant equipment. This allows you to see negative trending patterns before they turn problematic.

Wireless Nodes

Class II Div. 1



Class II Div. 2



Intrinsically Safe (I.S.) apparatus located in: Class II, Div 1, Groups E, F, G; Class III providing Intrinsically Safe (I.S.) connections for use in: Class II, Div 1, Groups E, F, G; Class III

Intrinsically Safe (I.S.) apparatus located in: Class II, Div 2, Groups F,G providing Intrinsically Safe (I.S.) circuits for use in: Class II, Div 1, Groups E,F,G; Class III

Installation Flexibility

- HazardPRO wireless nodes do not need conduit, This allows installations to be completed in a few days as opposed to the weeks or months that traditional systems need.
- Nodes can easily be mounted in almost any location. They can be magnetically mounted to most metal surfaces to provide quick/easy installation.
- Without the need for wired power, wireless nodes can be mounted on any moving machinery. This benefit allows for entirely new monitoring solutions for your facility.

Signal Reliability

- Every time a transmission is sent, an acknowledgement must be returned by the receiver. The transmitter uses different channel frequencies on retries to ensure that the data gets through. Each transmission is logged and regular “health” checks must arrive when they are expected.

Certified Hazard Monitoring

- Independently powered nodes provide breakthrough wireless hazard monitoring solutions while still keeping the critical Class II Div. 1 approvals.



SYSTEM COMPONENTS

Transmitter Node

- Transmit-on-change keeps data current
- Heartbeat transmissions verify reliable communications
- Standard M12 sensor connection for easy installation
- No external power required
- 5+ year battery life
- 10 inputs available for: shaft speed, belt alignment, bearing temperature, ambient temperature, and contact closure



* Class II Div. 1 or
Class II Div. 2 Models Available

Shaft Speed Sensor

- Measure shaft RPM speeds between 0-300
- Multiple mounting configurations
- Optional mounting magnet if shaft is not tapped
- Tap with 1/2" thread
- Automatic calibration of 10 and 20 percent slow down



Bearing Temperature Sensor

- No calibration required, set points adjusted to ambient sensor
- Stainless steel probe with zerk (grease) fitting
- Probe lengths available 4", 6", 8", 10"
- Replaces existing zerk (grease) fitting
- Measure between -40 °F → 248 °F (-40 °C → +120 °C)



Ambient Temperature Sensor

- Monitoring local ambient temperature continuously adjusts set points on bearing and belt alignment sensors
- Multi-point placement on each side of equipment for highly accurate tracking



SYSTEM COMPONENTS

Belt Alignment Sensor

- Brass rub block with easy-install mounting plate
- No calibration required, set points adjusted to ambient sensor
- Built-in, wear-detect feature notifies user when the belt alignment sensor needs to be replaced
- Bolt on assembly or HazardPRO rub-block door options



Stud Sensor

- Compatible with any standard Electro-Sensors' rub block
- Intrinsically safe 3/8-16" temperature probe
- Provides nearly unlimited applications

Optional

Magnetic surface mount for hassle-free temperature monitoring



Diaphragm Switch

- Point level detection in bins and hoppers
- Optimal for plugged chute applications
- Adaptable sensitivity



Cable Types

- All Sensors are offered with polyurethane or steel jacket cable
- Standard cable lengths sold with each sensor are 3 meters
- Extension lengths available upon request



5-Year Warranty on System Components, 1-Year on System Manager.



HazardPRO™

Wireless Hazard Monitoring

Contact Electro-Sensors today to see
how HazardPRO can change the way you
safeguard your people, processes, and facilities.



6111 Blue Circle Drive • Minnetonka, MN 55343
phone: 952-930-0100 • toll free: 800-328-6170 • fax: 952-930-0130
web: electro-sensors.com • email: sales@electro-sensors.com