

H100T

Description:

The Model H100T Analog Tachometer is a complete system capable of providing the user with a linear, visual indication of rates as low as 25 rpm full scale. The H100T utilizes the latest in solid state circuitry, has three switch selectable speed ranges, 0-50 rpm, 0-500 rpm and 0-5000 rpm, and an accuracy of $\pm 2\%$. The easily readable display with the 4-inch wide, 50-division scale can be factory scaled to read out in desired engineering units.

Principle of Operation:

While the monitored shaft is rotating, the pulser disc or wrap, mounted on the shaft generates an alternating magnetic field whose frequency is proportional to the speed of the monitored shaft. This magnetic field is detected by the sensor and is transmitted to the meter. There the signal is converted to an analog reading that is directly proportional to the shaft speed.

Pulser Disc:

The end of the shaft to be monitored must be center drilled to a depth of 1/2-inch with a No. 21 drill and tapped for 10-32UNF. After applying Loctite® or a similar adhesive on the threads to keep the pulser disc tight. The pulser disc should be attached, decal side out, with the supplied 10-32UNF machine screw and lock washer.

Pulser Wrap (optional):

Pulser Wraps are custom manufactured to fit the shaft they will be mounted on. When the wrap is shipped, four Allen-head cap screws hold the two halves of the wrap together. These screws must be removed so that the wrap is in two halves. Place the halves around the shaft, reinsert the screws and torque them to 8 foot pounds.

Sensor Installation:

The standard sensor is supplied with a mounting bracket and two jam nuts. The explosion-proof sensor is supplied with a slotted mounting bracket. Sensors should be installed so the centerline of the magnets pass in front of the center of the sensor as the disc or wrap rotates. When using the pulser disc, the center of the magnetized area of the disc, shown as Dimension B in figures 1 and 3, is 1-3/4 inches from the center hole of the disc.

The gap distance between the sensor and the disc or wrap, Dimension A in the diagrams, can be from 3/8 inch $\pm 1/8$ inch. To achieve the proper gap distance, adjust the jam nuts holding the standard sensor in the mounting bracket, or adjust the position of the explosion-proof sensor using the slots on its mounting bracket.

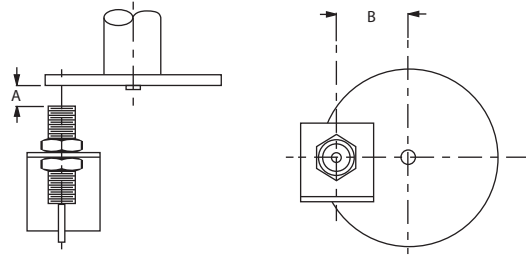

Figure 1: Standard 906 Sensor with 255 Pulser Disc

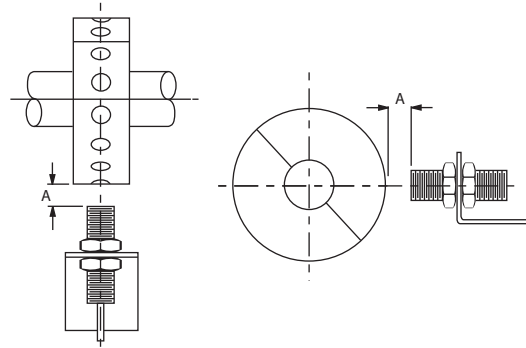

Figure 2: Standard 906 Sensor with optional Pulser Wrap

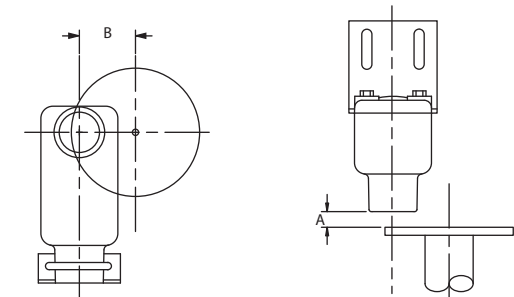

Figure 3: Explosionproof 907 Sensor with 255 Pulser Disc

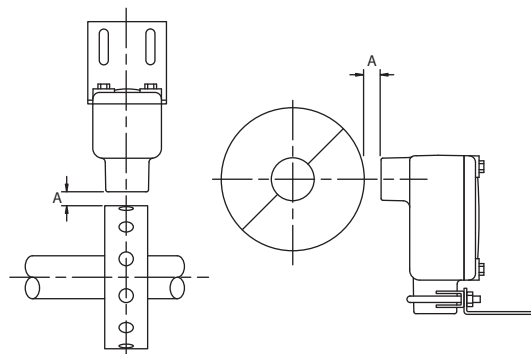

Figure 4: Explosionproof 907 Sensor with Pulser Wrap

Meter Installation:

Figure 5 illustrates the cutout necessary for installation of the H100T Analog Meter into a panel. After the cutout has been made, remove the two nuts which secure the circuit board to the meter. Remove the circuit board. Remove the nuts and washers from each of the four meter mounting screws and slide the meter into the panel. Re-install the nuts and the washer on the four meter mounting screws. Tighten the nuts until the meter is held securely in place. Be careful not to over-tighten, or damage may occur to the meter housing. Be sure to observe the correct polarity, and re-install the circuit board by using the two nuts removed earlier, then tighten securely. The unit is now ready for wiring.

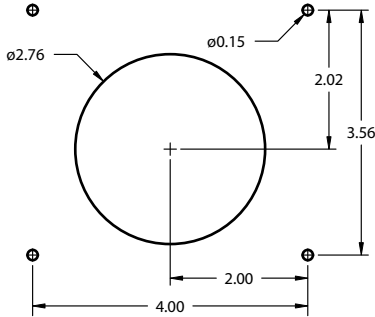

Figure 5: Panel Cutout

Sensor Input:

Terminal Description Sensor Model All Other ESI

| Terminal TB1 | Sensor model 906/907 | 916A/917A | Other ESI Sensors Type NPN | ESI Prox Type NPN |
|--------------|----------------------|--------------|----------------------------|-------------------|
| 4 Supply | Red | N/C | Red | Brown |
| 5 Signal | Black | White | White | Black |
| 6 Common | White/Shield | Black/Shield | Black/Shield | Blue |

Input Power:

| Power | TB1 | | |
|--------------|----------|----------|--------|
| | 1 | 2 | 3 |
| 115 Vac | Line | Neutral | Ground |
| 230 Vac* | Line | Line | Ground |
| 24 & 12 Vdc* | Positive | Negative | Ground |
| 24 @ 12 Vac* | High | Low | Ground |

* Note: Optional Power Input Option.

Wiring Connections:

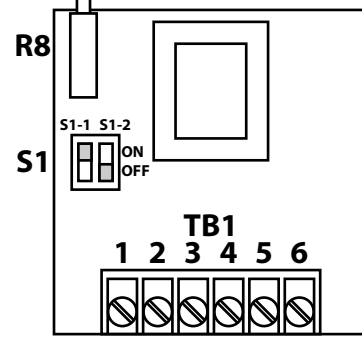

Figure 6: PCB View

Range Adjustment S1:

| Switch 1 | Switch 2 | Range |
|----------|----------|----------|
| OFF | ON | 0 - 50 |
| OFF | OFF | 0 - 500 |
| ON | OFF | 0 - 5000 |

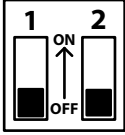

Figure 7: Setpoint Setup

Calibration:

Refer to figure 6 and 7 for the location of all calibration adjustments. All units are scaled and calibrated at the factory. **Customer must provide scale and calibration information when ordering.** Examples of this information would be: RPM range, shaft size for FPM, gallons per revolution for GPM, etc. If it should be necessary to field calibrate the meter, the following procedure should be followed:

1. Refer to figure 8. With the AC power OFF, adjust the screw adjustment on the front of the meter for a reading of zero on the meter. This is a mechanical zero.
2. Select the proper operating range on switch S1, using the table for proper positioning of S1-1 and S1-2, for the desired range.
3. With AC power applied and the shaft running at a known speed, adjust the GAIN ADJUSTMENT (R8) clockwise to increase, and counterclockwise to decrease for a meter reading of the known speed.

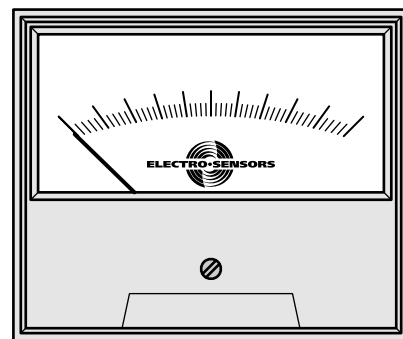
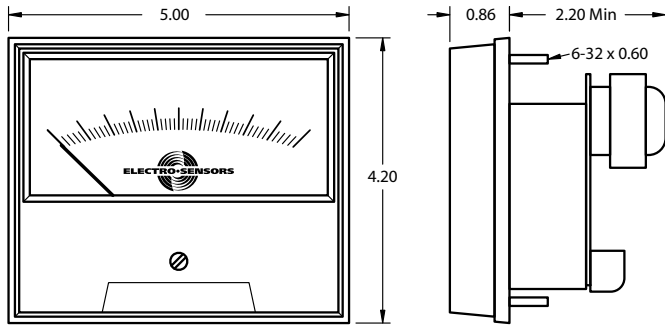

Figure 8: H100T Front View



Dimensional Drawings:



H100T

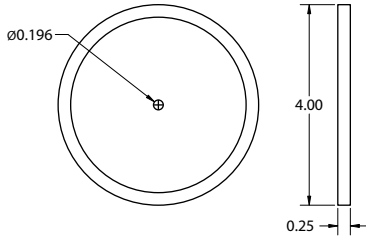

Pulser Disc

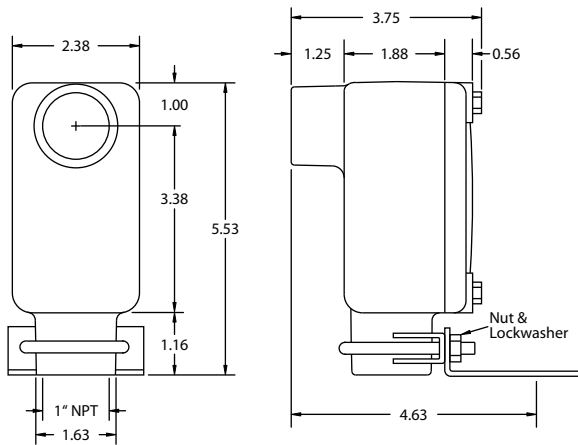

Explosion proof 907 Sensor

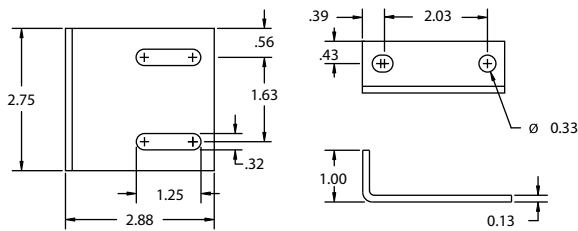

Explosion proof 907 Sensor Bracket

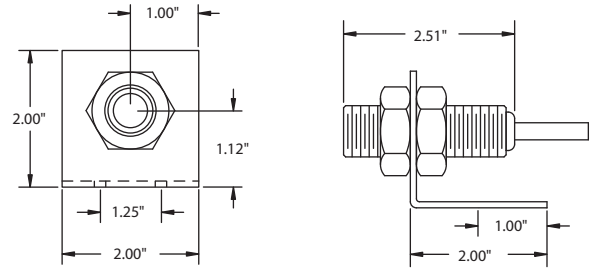

Standard 906 Sensor

Troubleshooting Guide:

| Symptom: No Rate or RPM Indication | |
|---|-------------------------------|
| Possible Causes: | Possible Solutions |
| Power is not applied to the H100T correctly | See page 2, Input Power |
| Switch is not aligned, or gapped properly. | See page 1, figures 1 and 2 |
| Check proper wiring for sensor type | See page 2, Sensor Input type |

General Specifications:

| Electrical | Parameters |
|------------------------|---|
| Input Power | 115 Vac \pm 10% Standard 230 Vac, 24 Vac, 24 Vdc, 12 Vdc Optional |
| Electrical Connections | 6 pos Terminal Strip |
| Frequency | 50-60 Hz |
| Wattage | 2.4 VA |

| Input Signal | Parameters |
|--------------|----------------------------------|
| Type | Open Collector Logic |
| Amplitude | 15 V Nominal, 7 V min, 60 V max. |
| Pull-up | 2200 Ohms to 15 V |
| Pulse Width | 100 μ -sec Minimum |
| Frequency | 800 Hz Maximum |

| Display | Parameters |
|------------------------|---|
| Type | Analog Needle Pointer |
| Scale Size | 4-Inch |
| Movement | Taut Band |
| Resolution | 50 Graduations |
| Accuracy | \pm 2% of Full Scale |
| Repeatability | \pm 0.1% |
| Calibration Adjustment | 15-Turn Potentiometer |
| Ranges | 0-50 rpm, 0-500 rpm and 0-5000 rpm Switch Selectable |
| Low Speed Filtering | Switch Selectable |
| Scaling | To Customer Specifications |



| Physical/Environment | Parameters |
|----------------------|-----------------------------------|
| Enclosure Material | Molded Phenolic with Glass Window |
| Operating Temp | 0°C to +65°C (32°F to 149°F) |
| Storage Temp | -20° to +65°C (-4°F to 149°F) |

| Pulser Disc | Parameters * |
|-------------|--|
| Material | Nylon 12 Std, (opt; PVC, Alum, Stainless-Steel) |
| Dimensions | 4-inch diameter x 1/4-inch thick |

| | |
|-----------------------|------------------------------|
| Operating Temperature | -40°C to +60°C* (Nylon, PVC) |
| Operating Temperature | -40°C to +150°C* (Alum, SS) |

| Pulser Wrap (optional) | Parameters ** |
|------------------------|--|
| Material | PVC Std. (opt; Aluminum or Stainless-Steel) |
| Operating Temperature | -40°C to +60°C* (PVC) |
| Operating Temperature | -40°C to +150°C* (Aluminum, SS) |

| 906 Sensor (Standard) | Parameters ** |
|------------------------|---|
| Material Sensor Body | Aluminum 3/4 - 16UNF thread |
| Material Mount Bracket | Plate steel |
| Output Types | NPN open collector current sinking 20 mA max |
| Signal Cable | 3-conductor shielded, 10 feet length std. (50 ft. or 100 ft. optional) |
| Operating Temperature | -40°C to + 60°C* |
| Air Gap | 1/4 inch +/- 1/8 inch |

| 907 Explosionproof Sensor (optional) | Parameters ** |
|---|--------------------------------|
|  Class I, Div 1, Group D Class II, Div 1, Groups E, F, G UL File: E249019  | |
| Mounting Bracket Material | Plate Steel U-Bolt Assembly |
| Other Specifications | Similar to 906 standard sensor |

*Higher Temperature Ranges Available Consult Factory

**Specifications Subject to Change without Notice

HI00T Spare Parts List:

| Spare Parts List | Stock No. | Part No. |
|--------------------------------|-----------------|----------|
| Meter Assembly, Complete | 800-004200 | |
| Meter Movement only, w/ Scale | 510-000100 | 264 |
| Standard Digital Sensor | 775-000500 | 906 |
| Explosion proof Digital Sensor | 775-000600 | 907 |
| Pulser Disc | 700-000200 | 255 |
| Pulser Wraps | Consult Factory | |

